

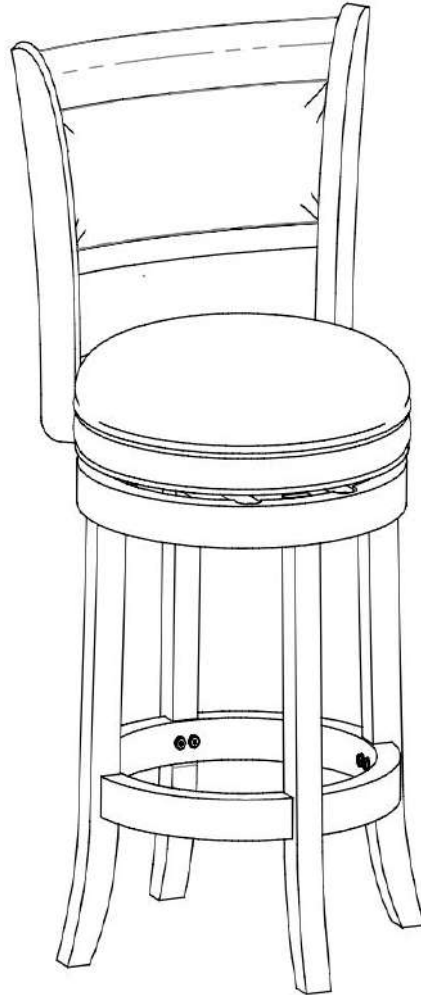

Boraam Industries

ASSEMBLY INSTRUCTIONS

SKU: 48834,49834,45834
AUGUSTA SWIVEL EXTRA TALL BARSTOOL



Weight Capacity



Locate the **HARDWARE PACK** which is attached to the shipping carton with red tape.

02/2024



Have questions about assembling your item?



Items or parts damaged?



Missing a part?

We're here to help! (Monday-Friday from 9am-5pm CST)



847-949-6300
877-267-2261



customerservice@
boraamindustries.com



www.boraamindustries.com

Assembly And Care

- All tools required for assembly are included unless noted.
- Prior to assembly, check for missing or damaged parts.
- Do not dispose of packing materials until assembly is completed.
- Assemble item on a soft, clean surface to prevent damage to the item.



Locate the **HARDWARE PACK** which is attached to the shipping carton with red tape.

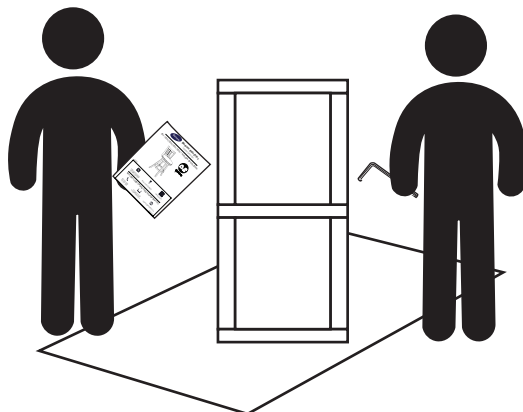
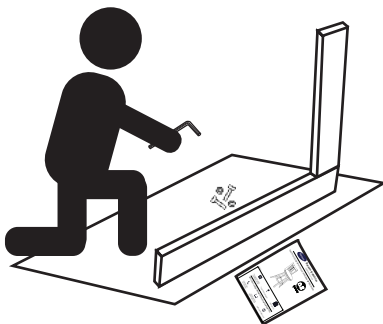
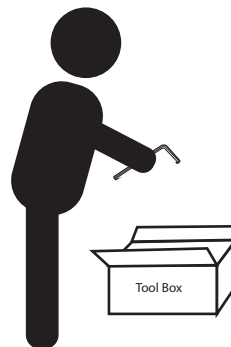
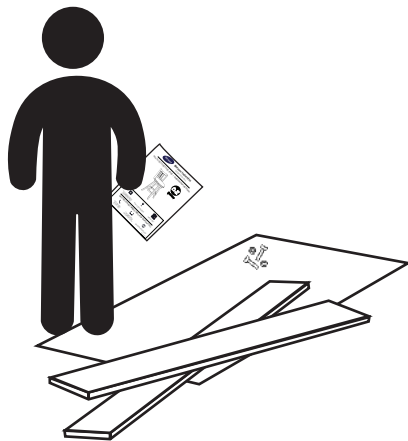

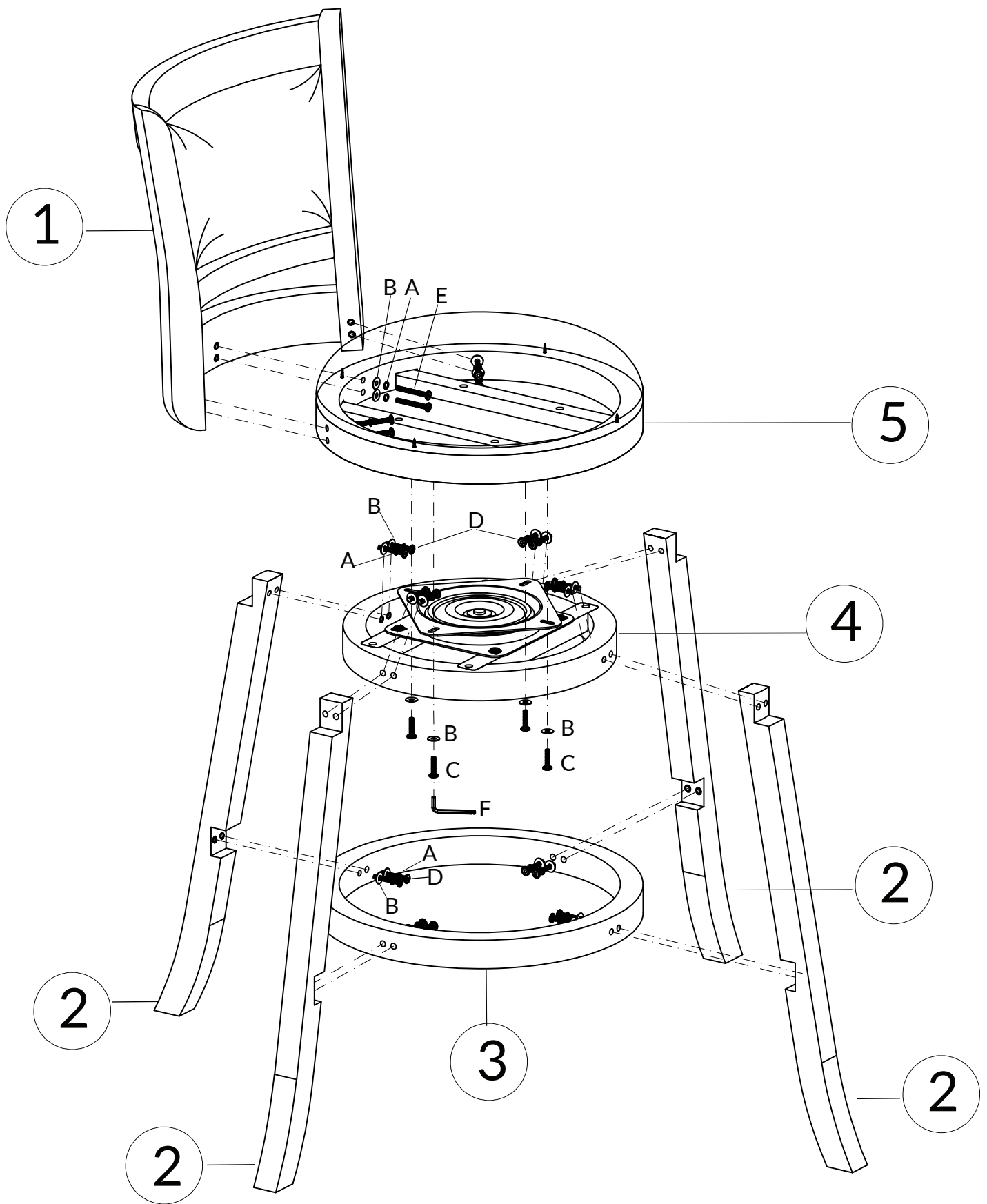

Assembly Overview

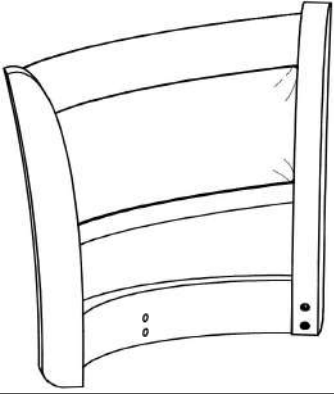
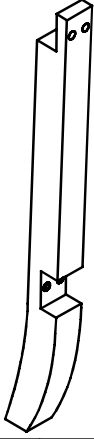
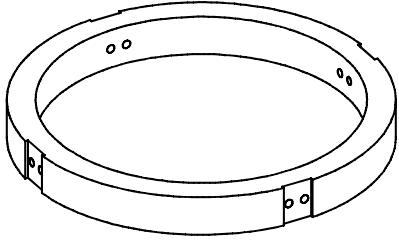
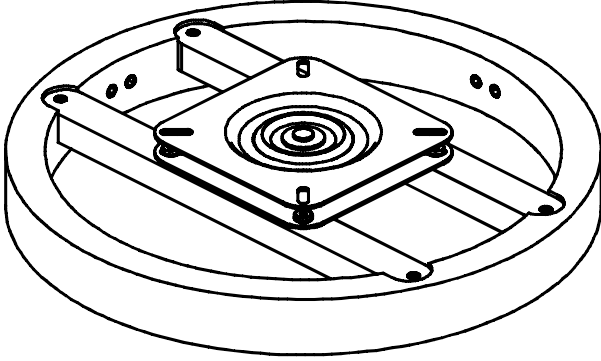
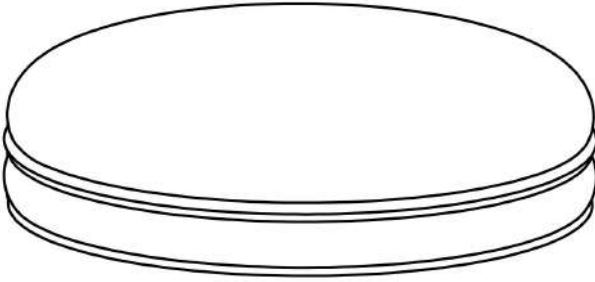

PARTS

<p>①(x1)</p>	<p>②(x4)</p>	<p>③(x1)</p>
<p>Backrest :</p> 	<p>Legs :</p> 	<p>Footrest :</p> 
<p>④(x1)</p>		<p>⑤(x1)</p>
<p>Apron With Swivel Plate :</p> 	<p>Seat Cushion :</p> 	

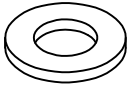
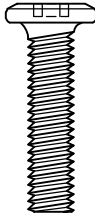
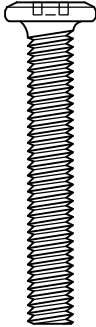
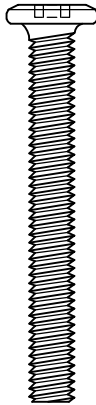
HARDWARE

<p>Ⓐ(x22)</p>	<p>Ⓑ(x26)</p>	<p>Ⓒ(x4)</p>	<p>Ⓓ(x16)</p>	<p>Ⓔ(x6)</p>	<p>Ⓕ(x1)</p>
					
<p>Spring Washer M6*10</p>	<p>Flat Washer M6*16</p>	<p>Bolt M6*25</p>	<p>Bolt M6*40</p>	<p>Bolt M6*50</p>	<p>Allen Wrench M4*110</p>

847-949-6300 | 877-267-2261 | customerservice@boraamindustries.com

01

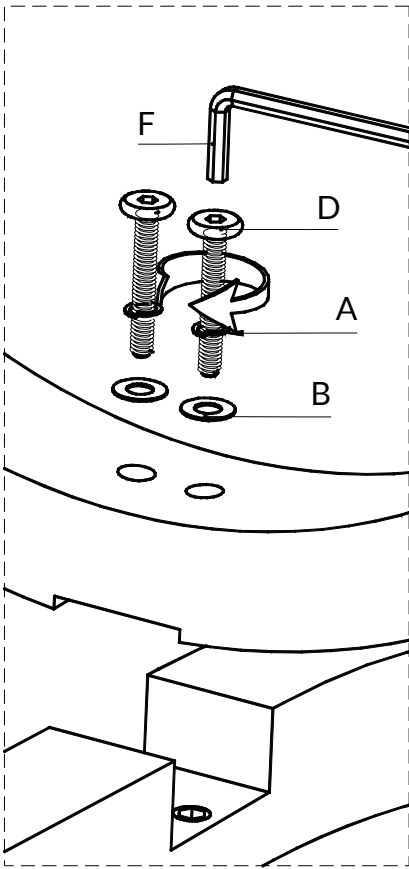

4X

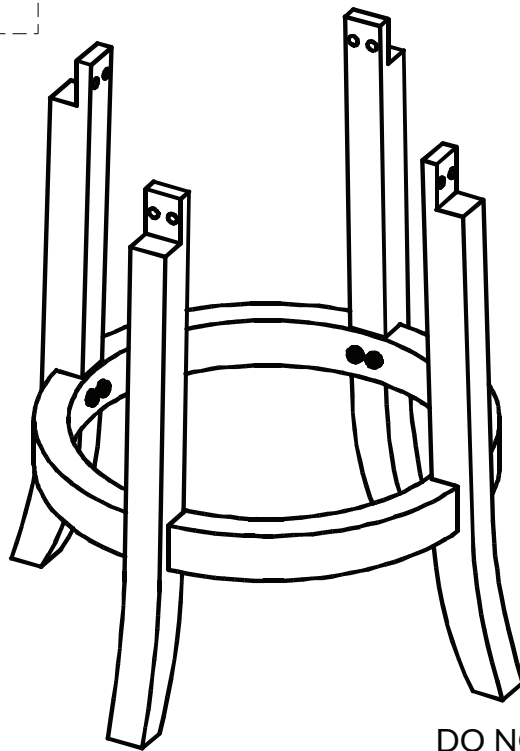
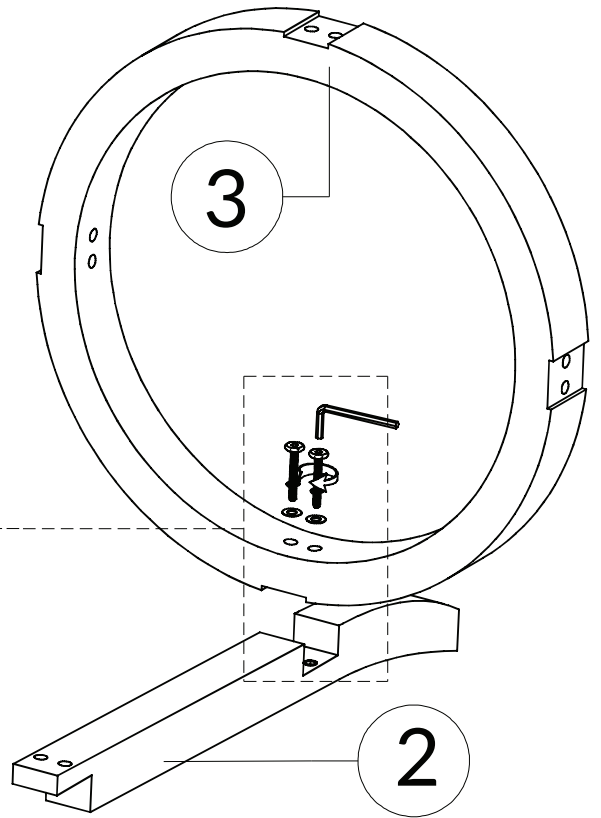

Hardware	Count
A	8
B	8
D	8
F	1

DO NOT TIGHTEN BOLT COMPLETELY.

Please make sure that the protective metal kick plate from Footrest (Part #3) is facing upwards. Remove the white Tape from the protective metal kick plate before using.

847-949-6300 | 877-267-2261 | customerservice@boraamindustries.com

02

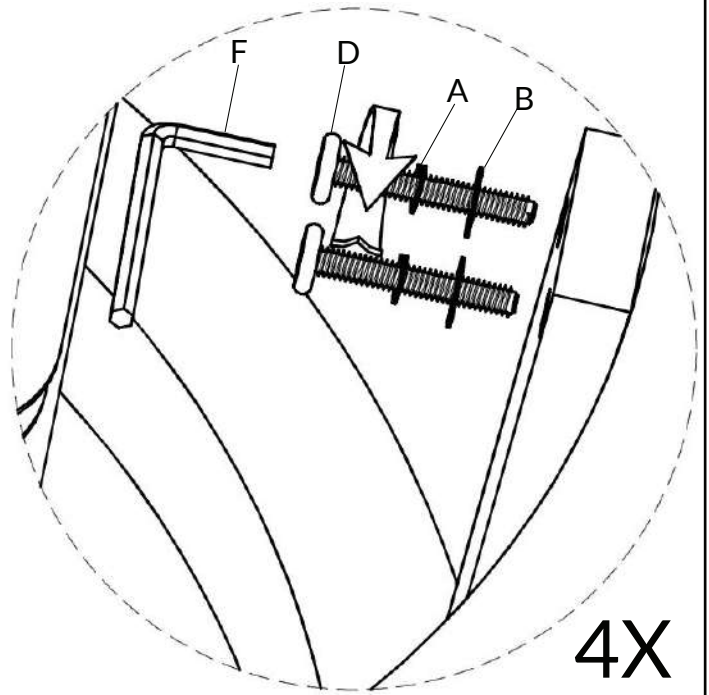
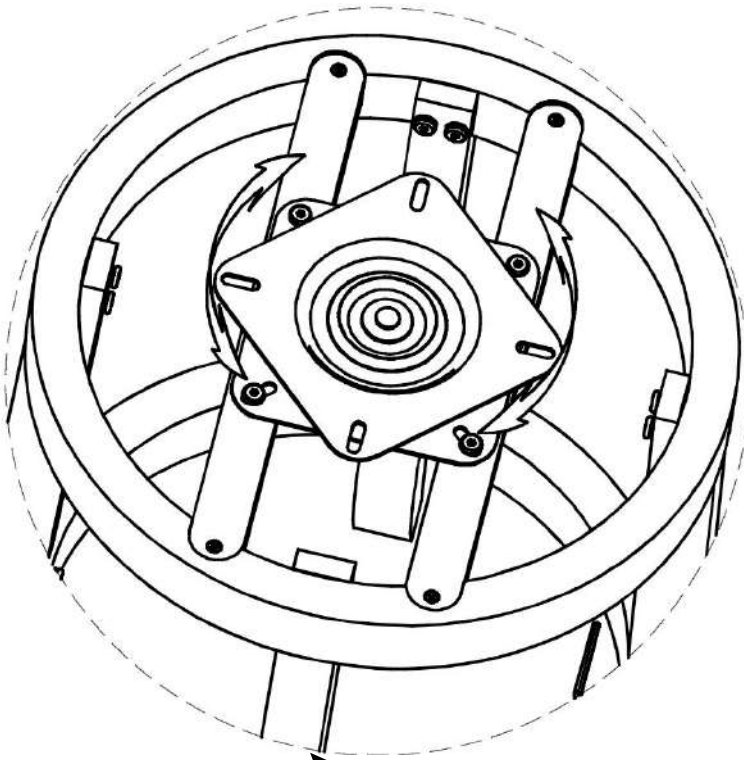

4X

4

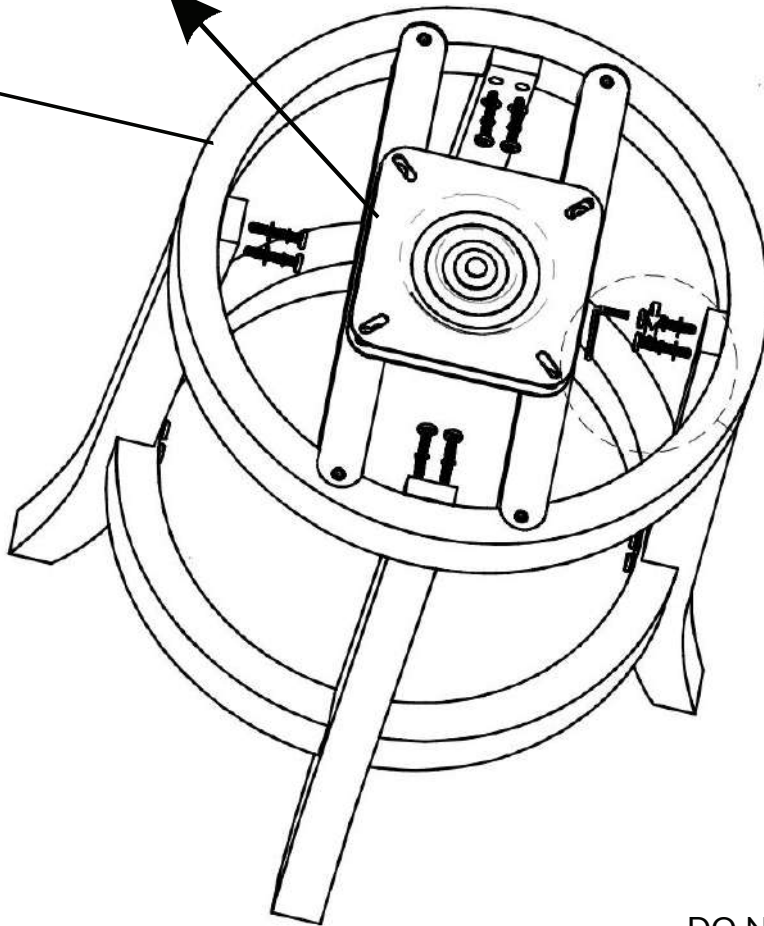

Hardware	Count
A	8
B	8
D	8
F	1

DO NOT TIGHTEN BOLT COMPLETELY.

03

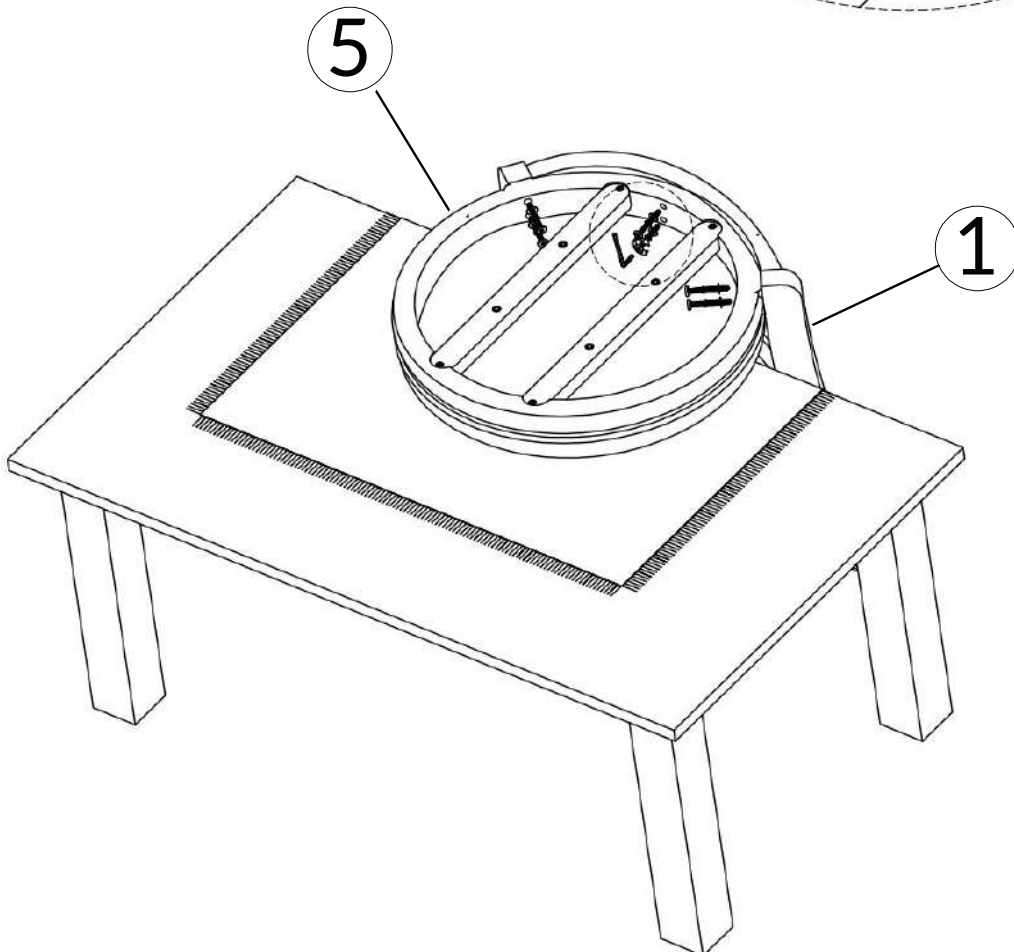
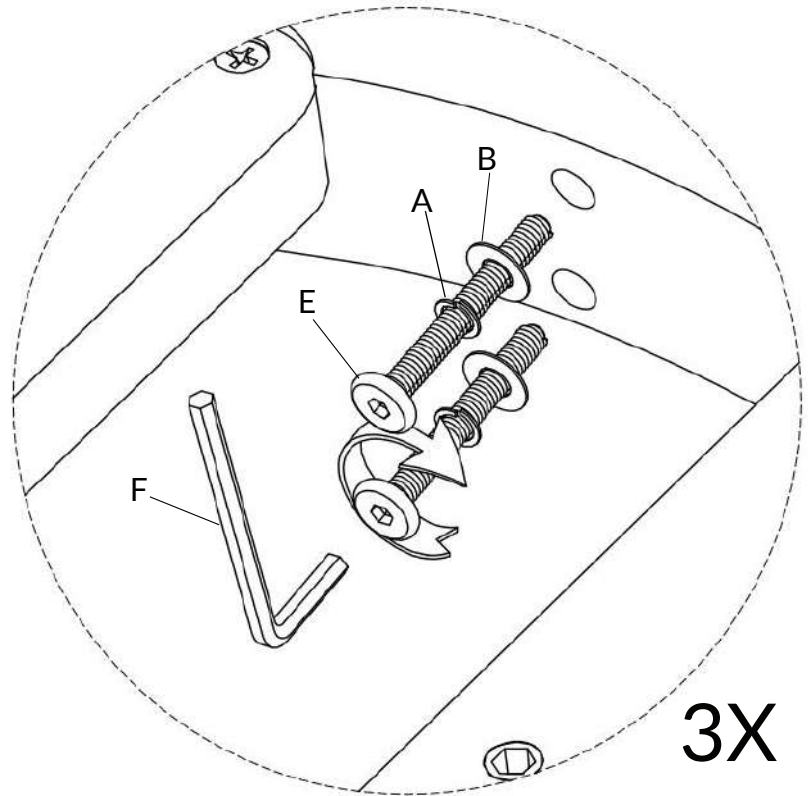

Hardware	Count
A	6
B	6
E	6
F	1

TIGHTEN BOLT COMPLETELY.

04

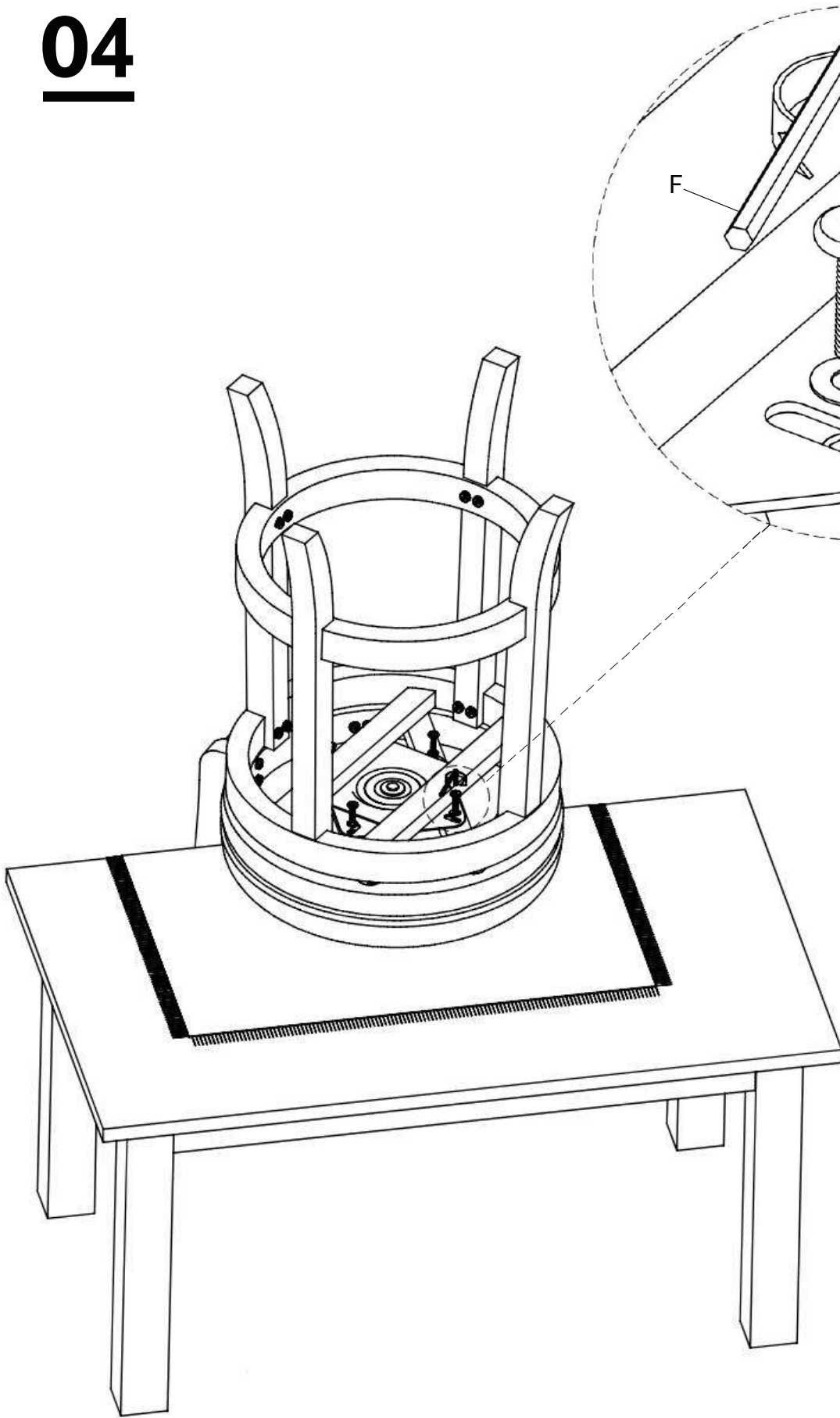

Hardware	Count
B	4
C	4
F	1

TIGHTEN BOLT COMPLETELY.

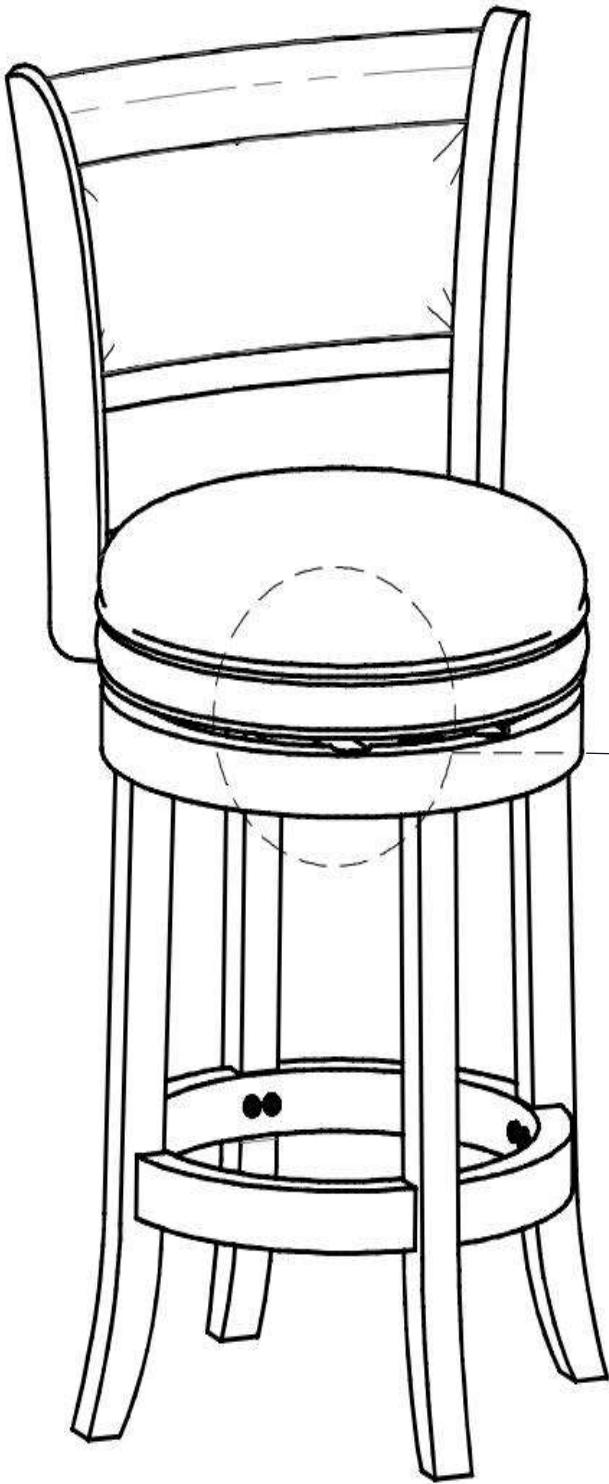

Weight Capacity

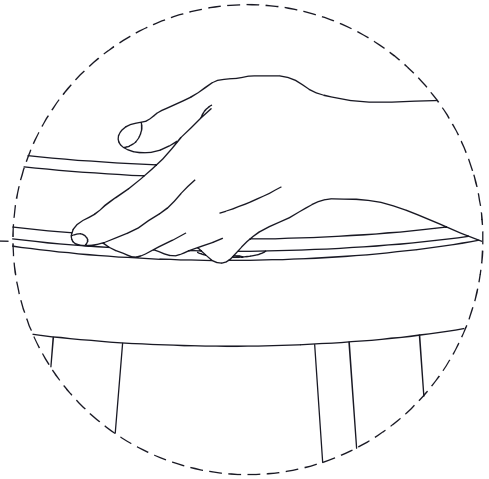

BE SURE TO CHECK ALL BOLTS ARE SECURELY TIGHTENED PRIOR TO USE.