

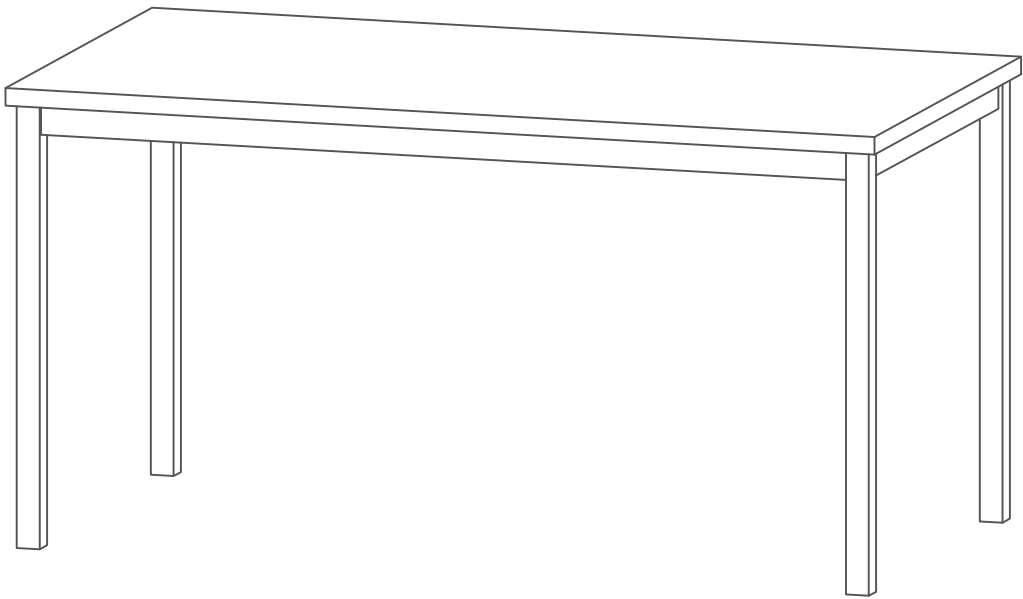

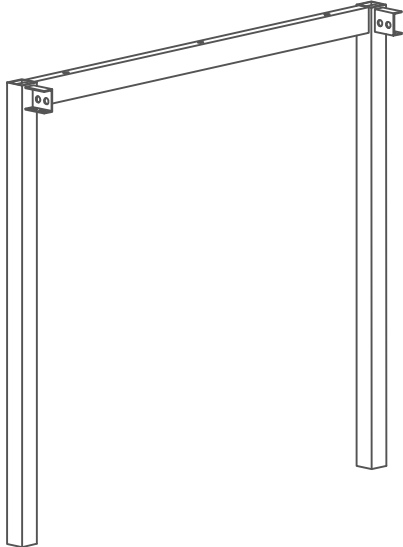





Assembly Instructions

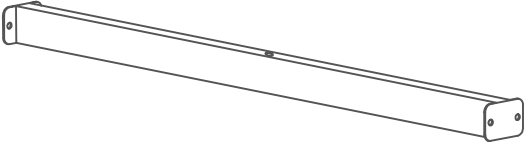
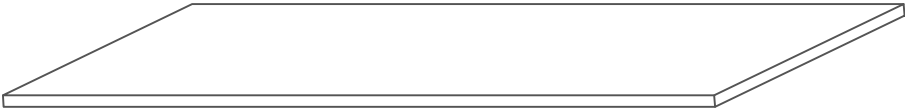

Parts List

Label	Picture	Qty
A		2
B		2
C		1
D		1
T - 1	 (M6X15)	20
T - 2	 (M5X70)	19
T - 3		4
T - 4		1
T - 5		1

Assembly Steps

ATTENTION:

DO NOT COMPLETELY TIGHTEN ANY SCREWS UNTIL ALL PARTS ARE IN PLACE

Step 1

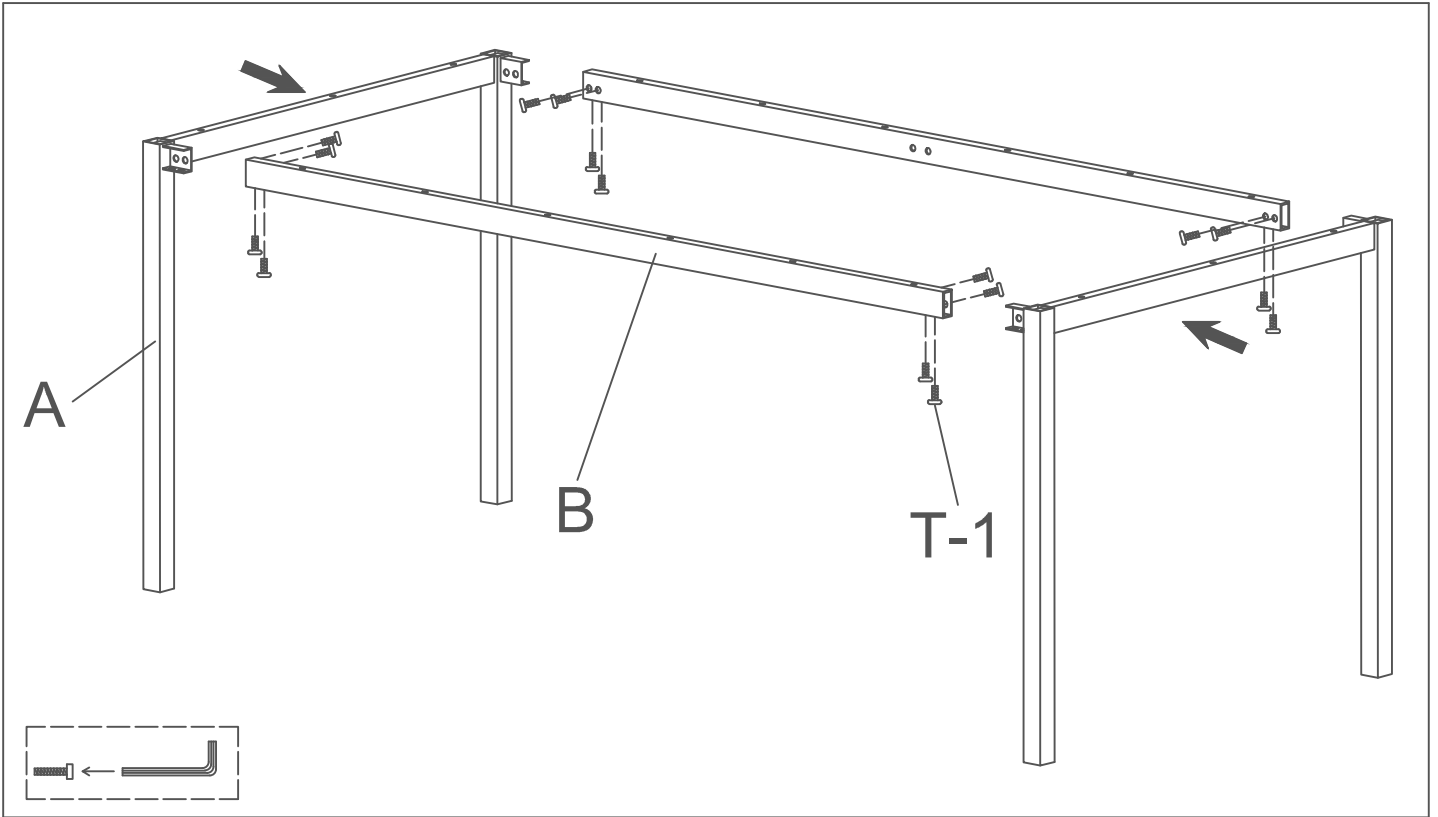

Step 2

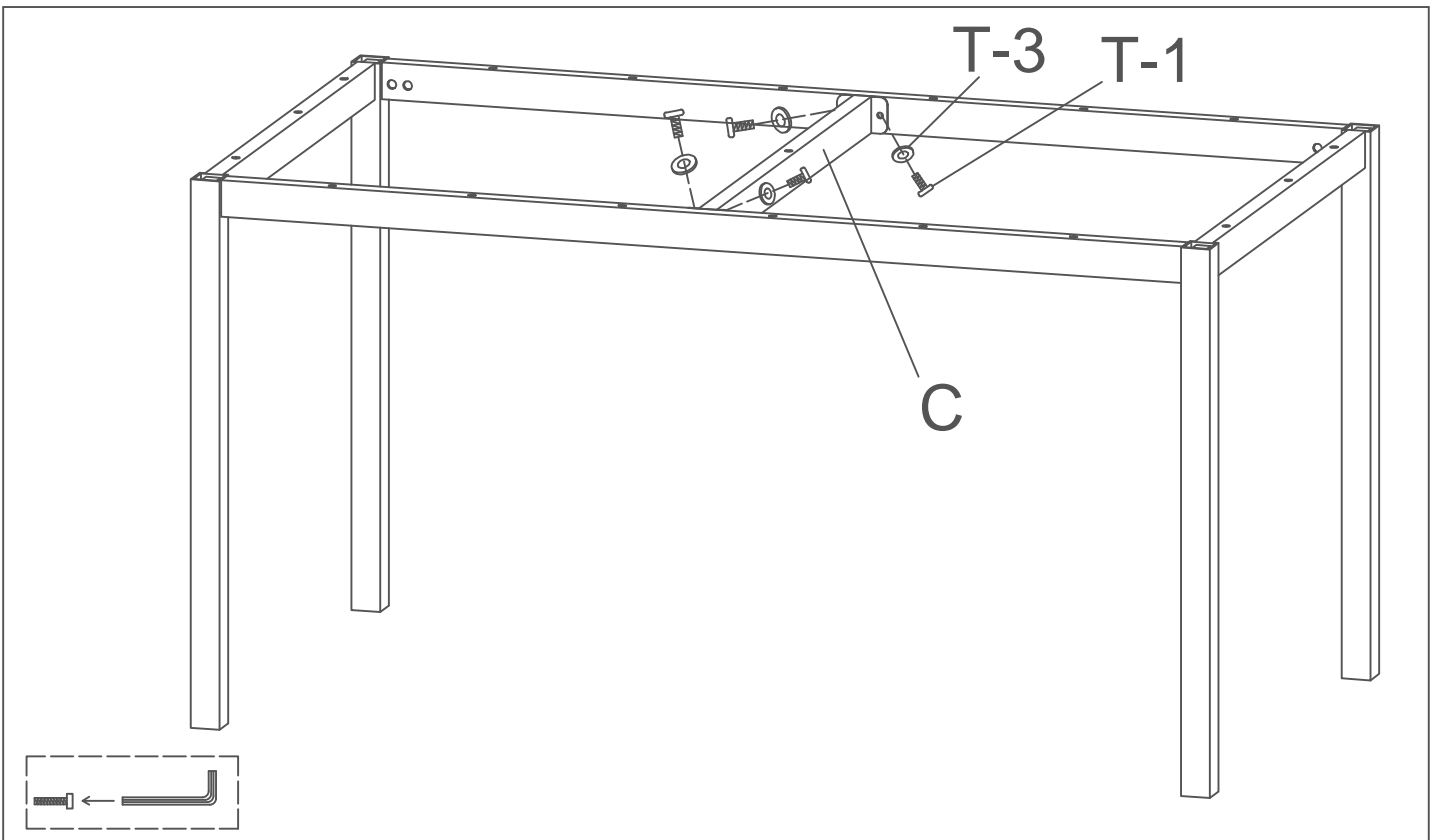

Step 3

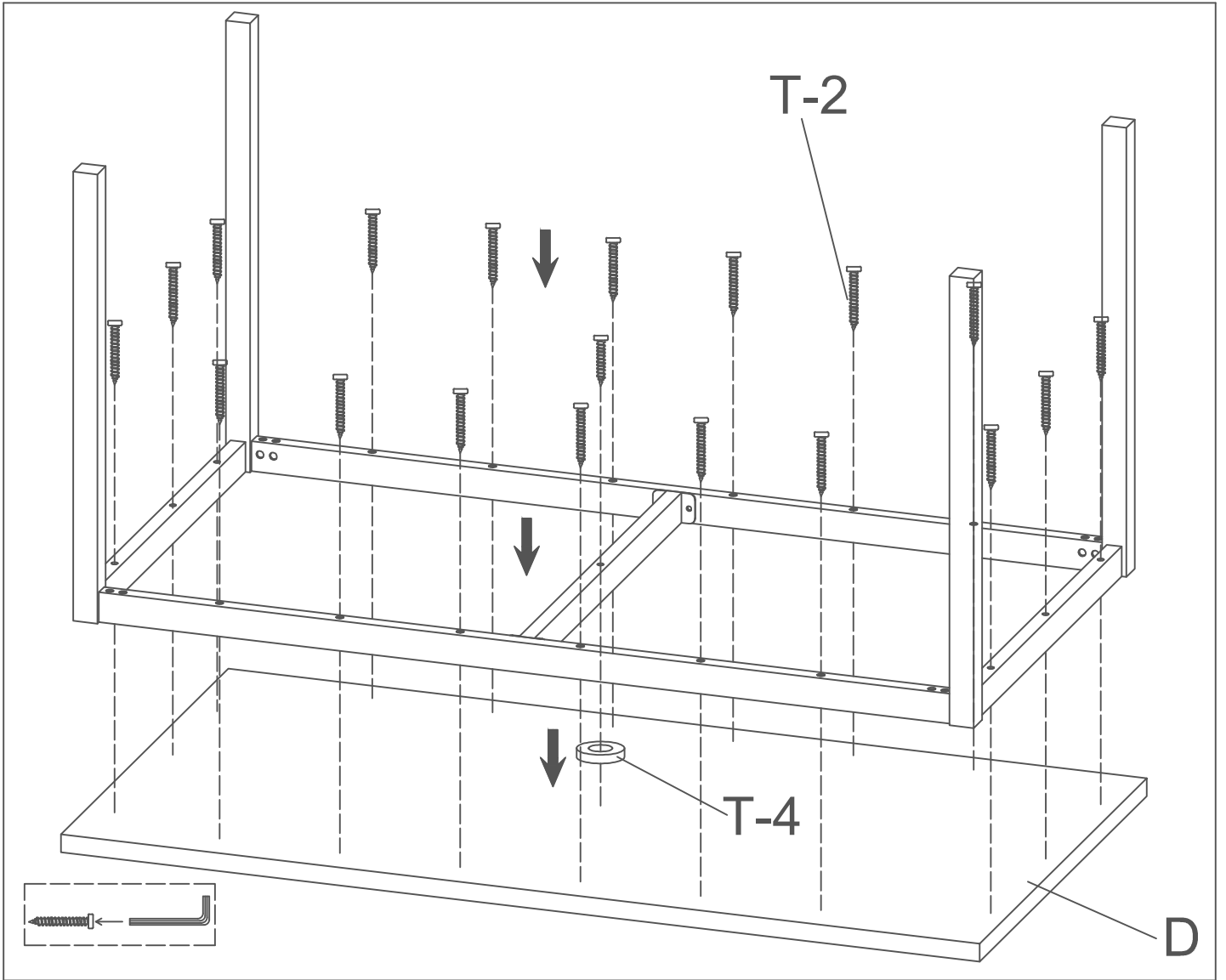

Step 4

