

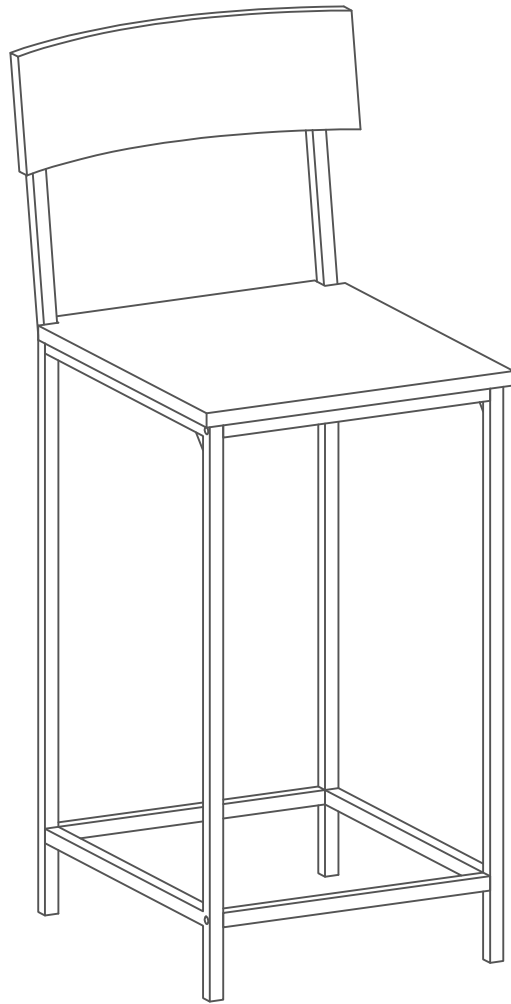

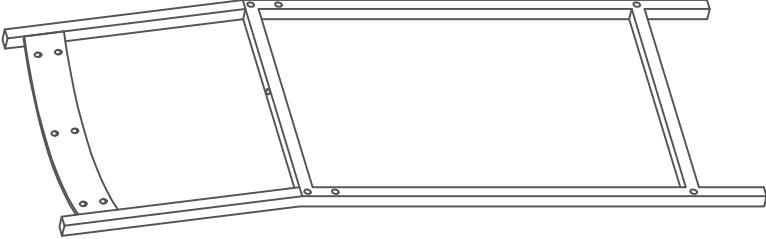

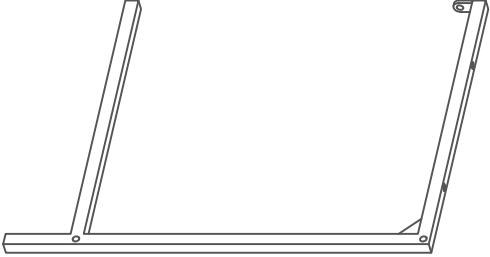

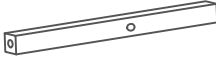

Assembly Instructions

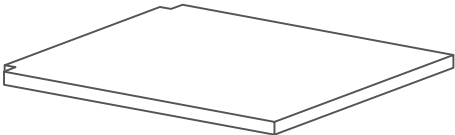
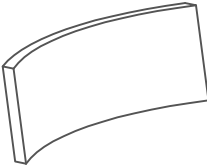

Parts List

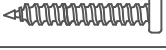
lable	Picture	Qty
A		1
B		2
C1		1
C2		1
D		1
E		1
T - 1	 (M6X15)	2
T - 2	 (M4X16)	6
T - 3	 (M6X30)	10
T - 4	 (M4X45)	4
T - 5		1

Assembly Steps

ATTENTION:

DO NOT COMPLETELY TIGHTEN ANY SCREWS UNTIL ALL PARTS ARE IN PLACE

Step 1

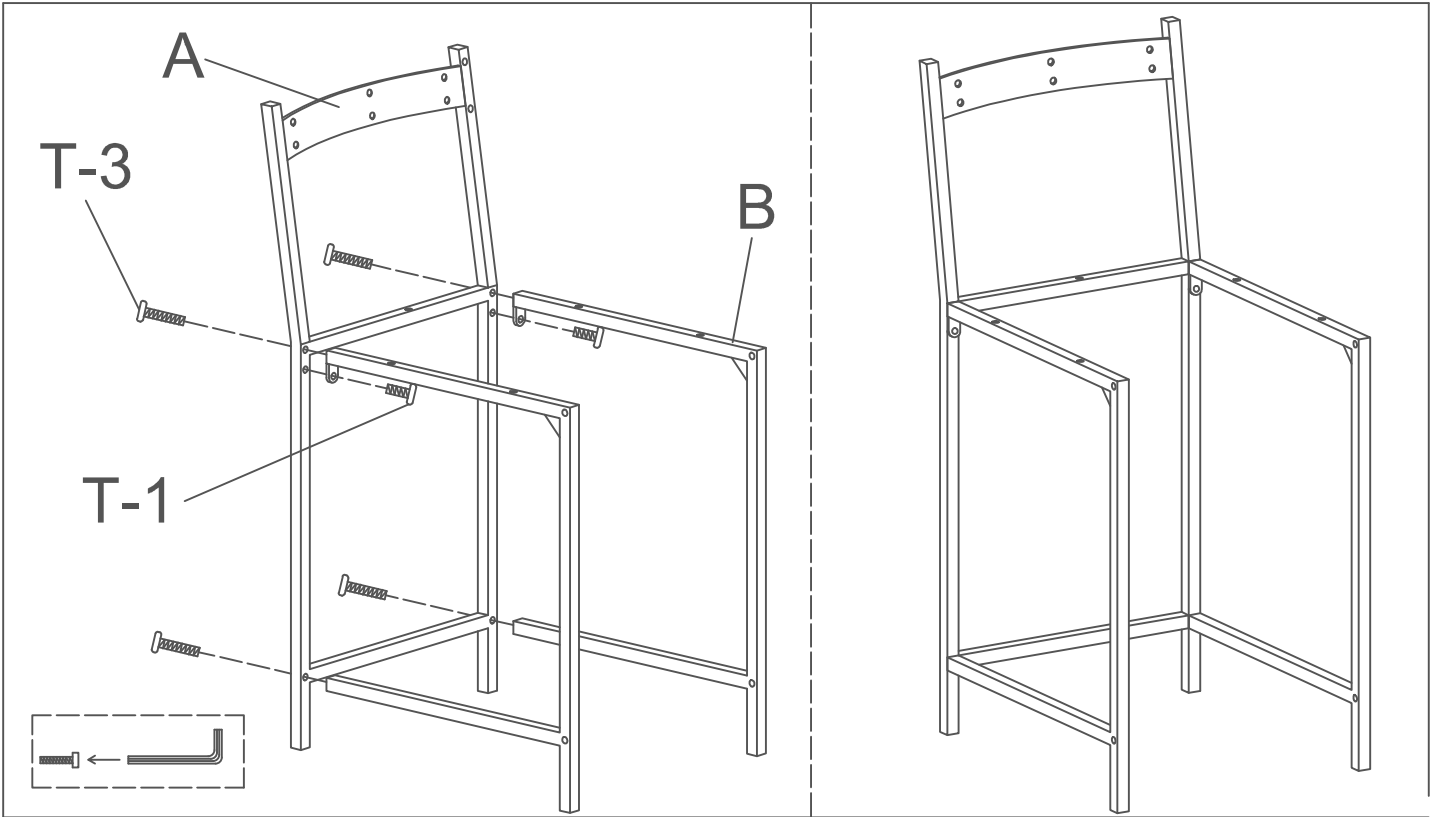

Step 2

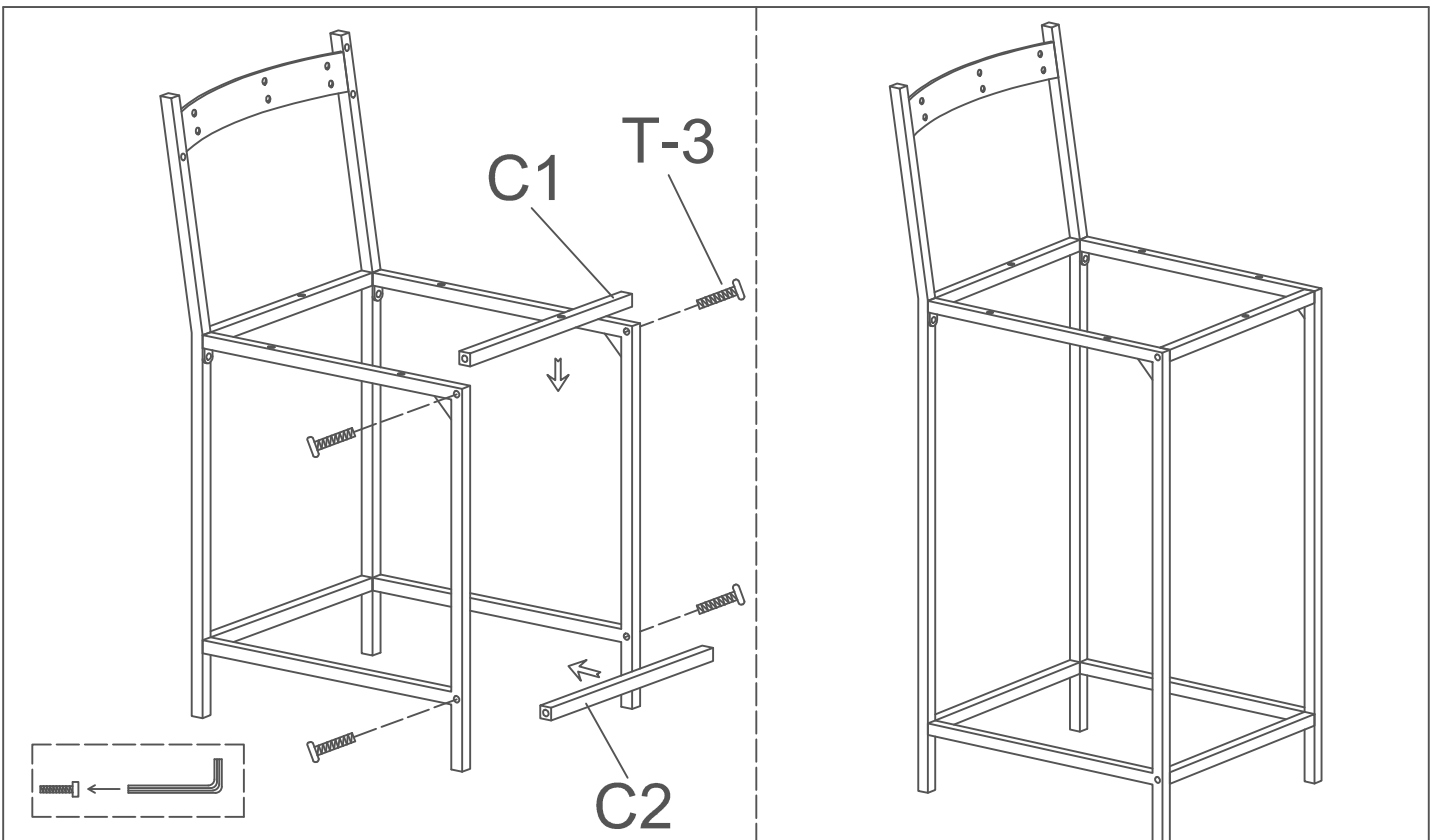

Step 3

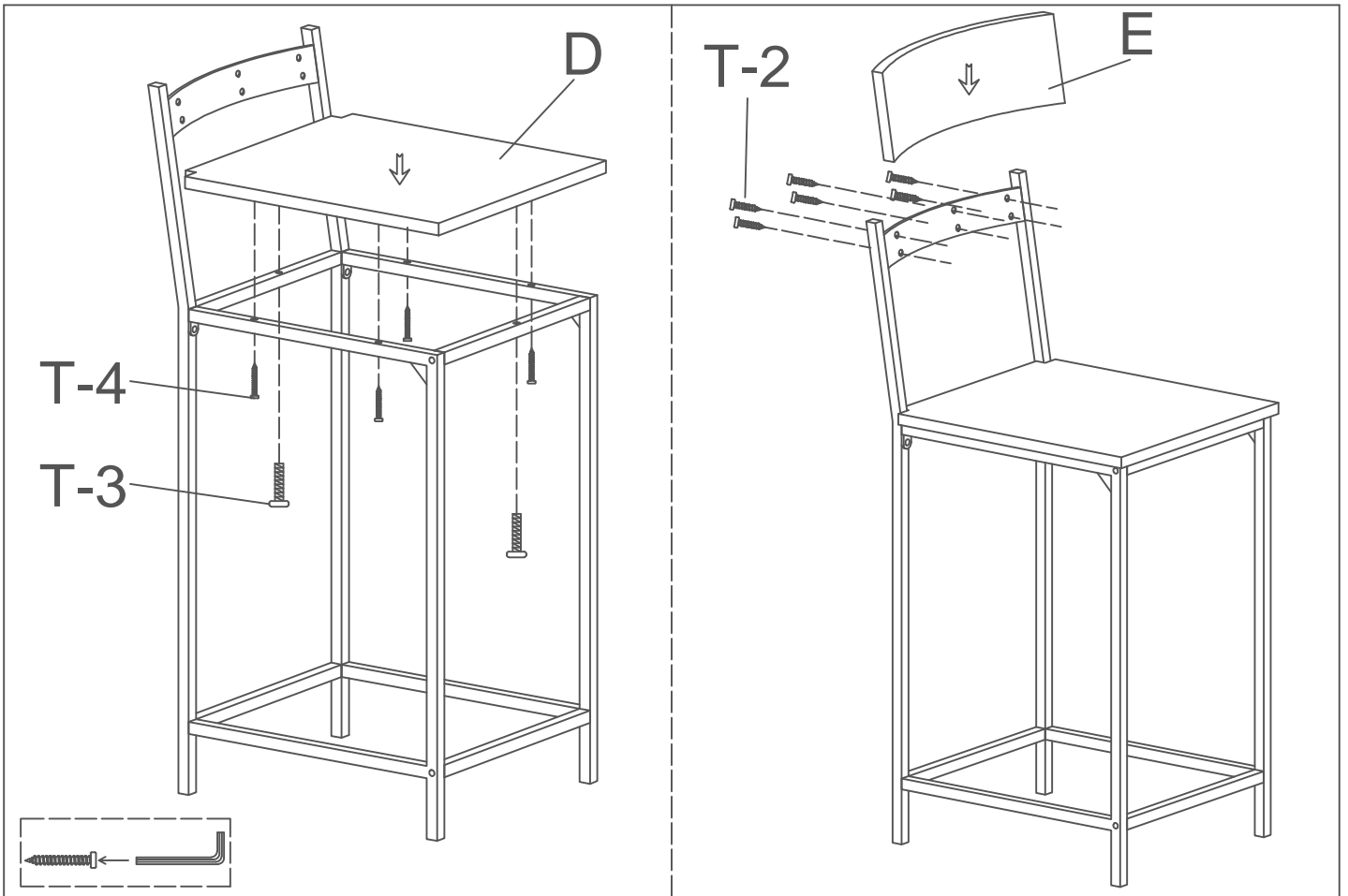

Step 4

