



# Boraam Industries

## Keyhole Rush Barstool Assembly Instructions

- **Tools Included**
- **Do not throw away packing materials until assembly is complete**
- **Assemble this item on a soft, clean surface to protect the product**
- **Proper assembly requires 2 People**
- **Make sure all parts are included prior to assembly**

PART LIST		
NO.	DESCRIPTION	QTY
A	Backrest	1
B	Seat box	1
C1	Front leg Left	1
C2	Front leg Right	1
D	Side stretcher top Left + Right	2
E	Side stretcher bottom Left + Right	2
F	Front stretcher top	1
G	Front stretcher bottom	1

HARDWARE LIST		
ITEM	DESCRIPTION	QTY
1	JCBC Bolt M8x80mm	4
2	JCBC Bolt M8x50mm	2
3	JCBC Bolt M6x35mm	6
4	Spring washer M8	6
5	Flat washer	6
6	Allen Wrench M4	1
7	Screw M4*30	6

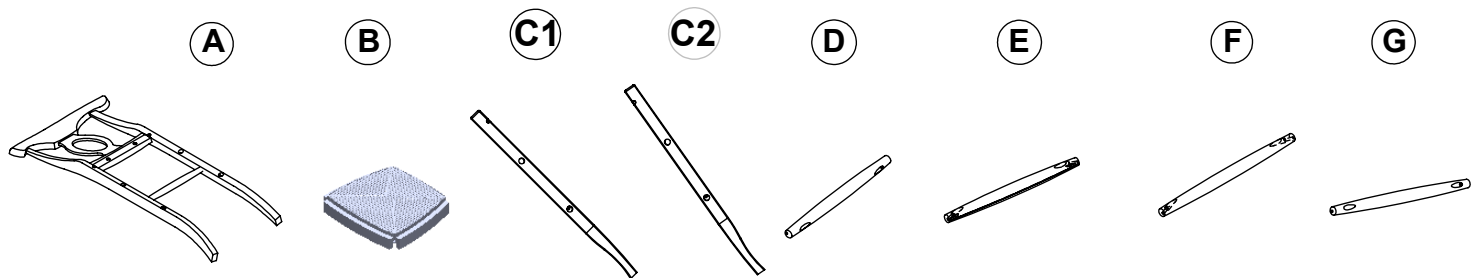

**Step 1: Assemble the Backrest A to the seat box B**  
DO NOT TIGHTEN ALL BOLTS AND SCREWS UNTIL ALL PART HAD ATTACHED

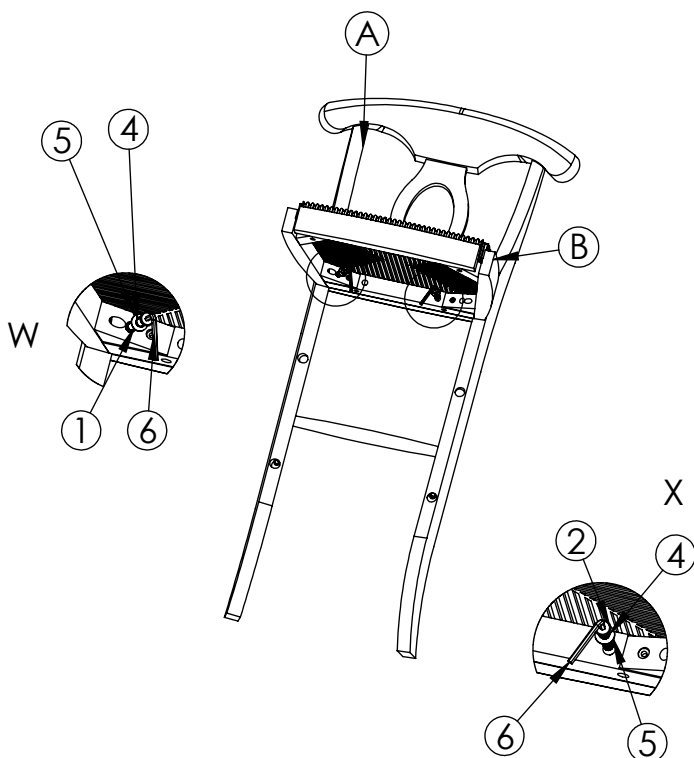

**Step 2: Assemble the Front leg C label L(left) to the seat box B and side Stretcher D&E**

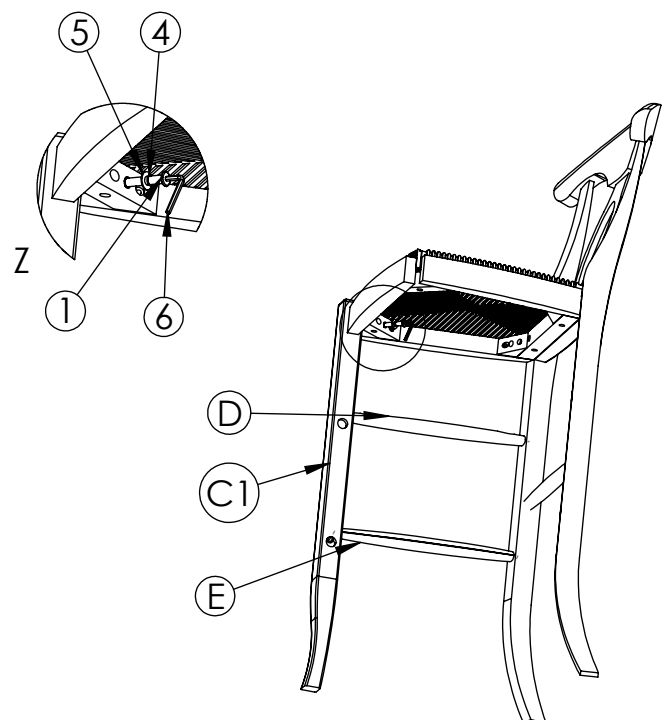

Step 3 : Assemble the Front leg C label R(right) to the seat box B and side Stretcher D&E

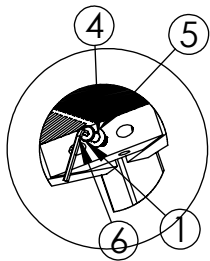
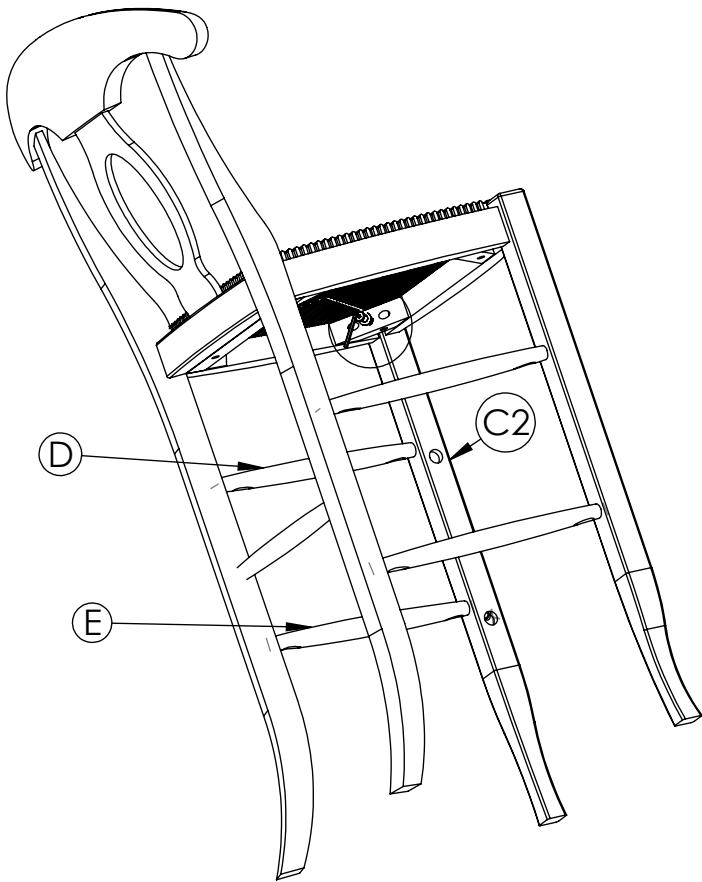

AA

Step 4 : Assemble Front Stretcher Top and Bottom F&G

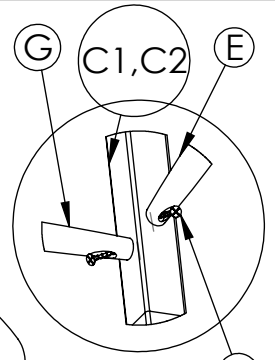
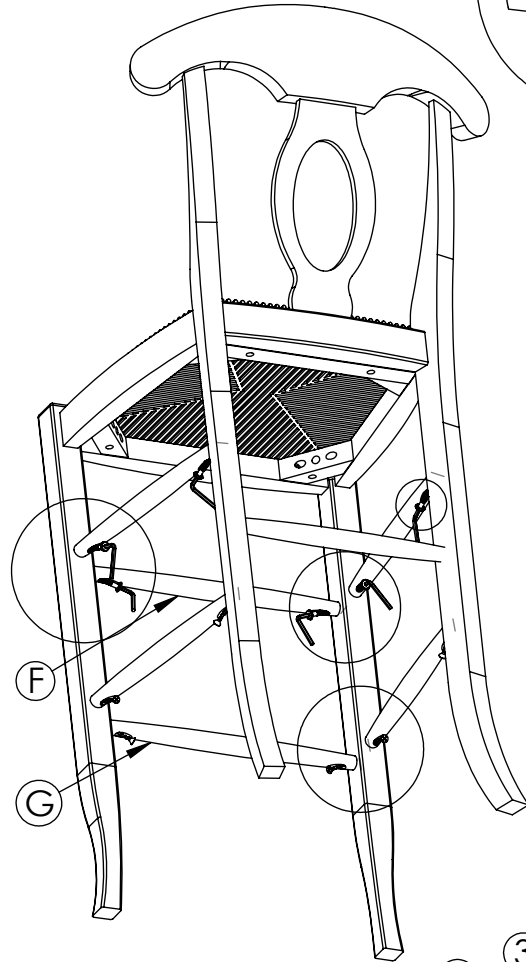

AH

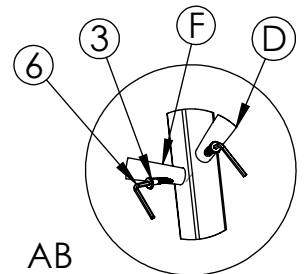

AB

Completed Assembly : Be sure to check all JCBC bolts and screws are tightened before use

