



Boraam Industries

FARO SWIVEL STOOL Assembly Instructions

- Tools Included
- Do not throw away packing materials until assembly is complete
- Assemble this item on a soft, clean surface to protect the product
- Proper assembly requires 2 People
- Make sure all parts are included prior to assembling

PARTS LIST

NO.	DESCRIPTION	QTY'
A	Backrest	1 Pc
B	Chair Leg	4 Pcs
C	Footrest	1 Pc
D	Apron with Swivel Plate	1 Pc
E	Seat Cushion	1 Pc

HARDWARE LIST

NO.	DESCRIPTION	SKETCH	QTY'
1	JCBC Bolt M6x25		4 Pcs
2	JCBC Bolt M6x40		10 Pcs
3	JCBC Bolt M6x50		4 Pcs
4	Spring Washer		14 Pcs
5	Flat Washer		18 Pcs
6	Allen Wrench M4		1 Pc

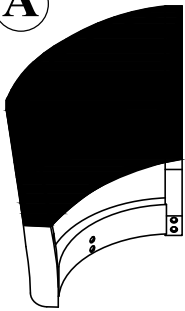
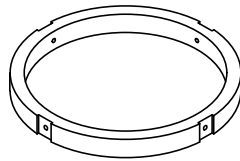
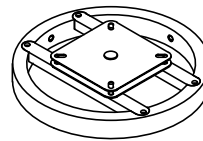
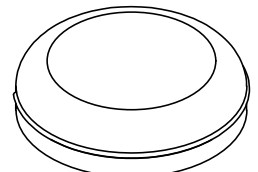
A**B****C****D****E**

Step 1

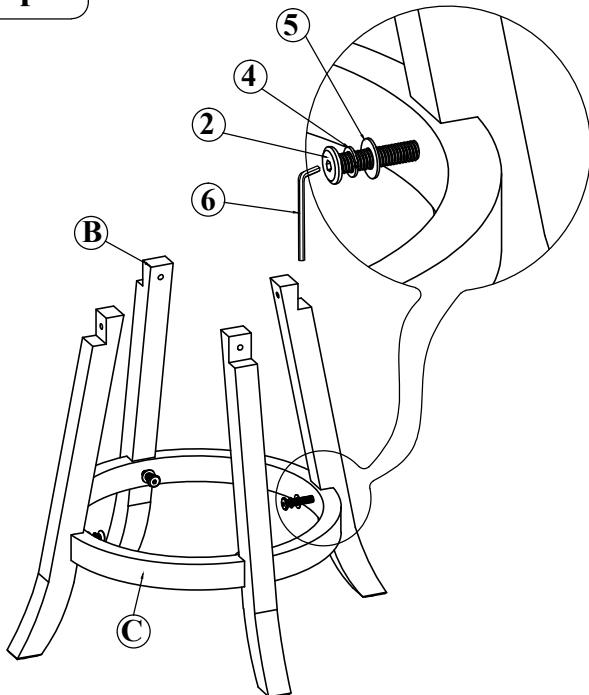

Attach each leg (B) to footrest (C). Insert each individual set of hardware as show in the picture. Do not tighten any hardware completely.

Step 2

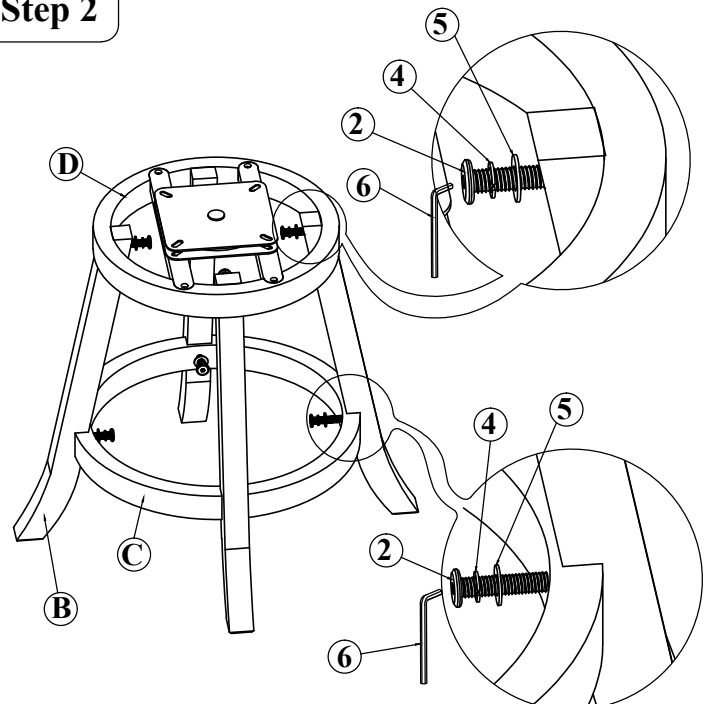

Attach each leg (B) to apron (D). Insert each individual hardware as show in the picture. Then tighten the 4 legs with apron first, then tighten the footrest with the 4 legs completely.



Boraam Industries

FARO SWIVEL STOOL Assembly Instructions

Step 3

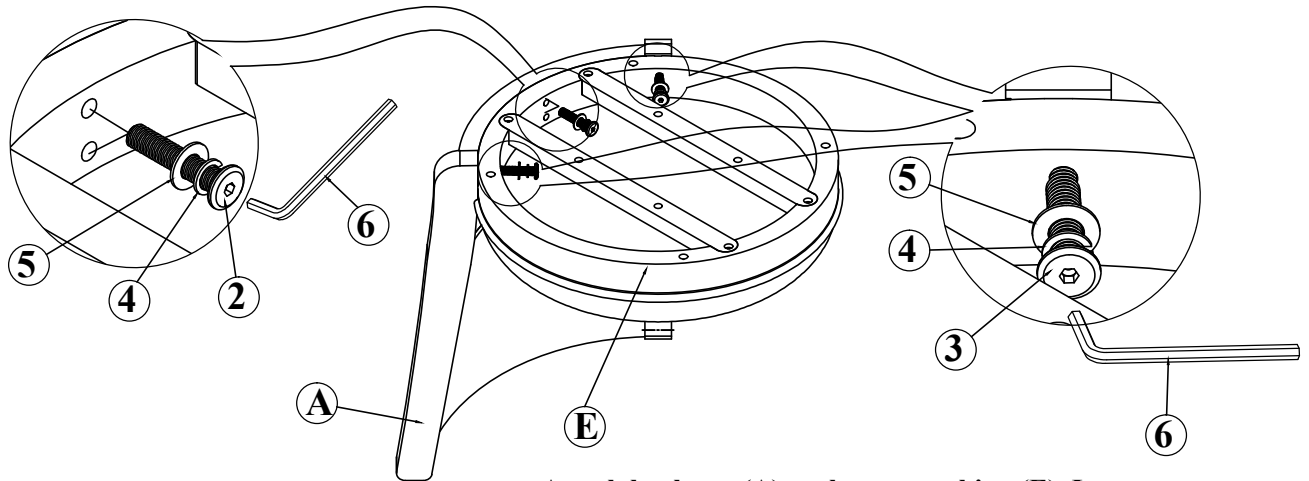

Attach backrest (A) to the seat cushion (E). Insert 6 sets of hardware as shown in the picture. Tighten together after alignment is done.

Step 4

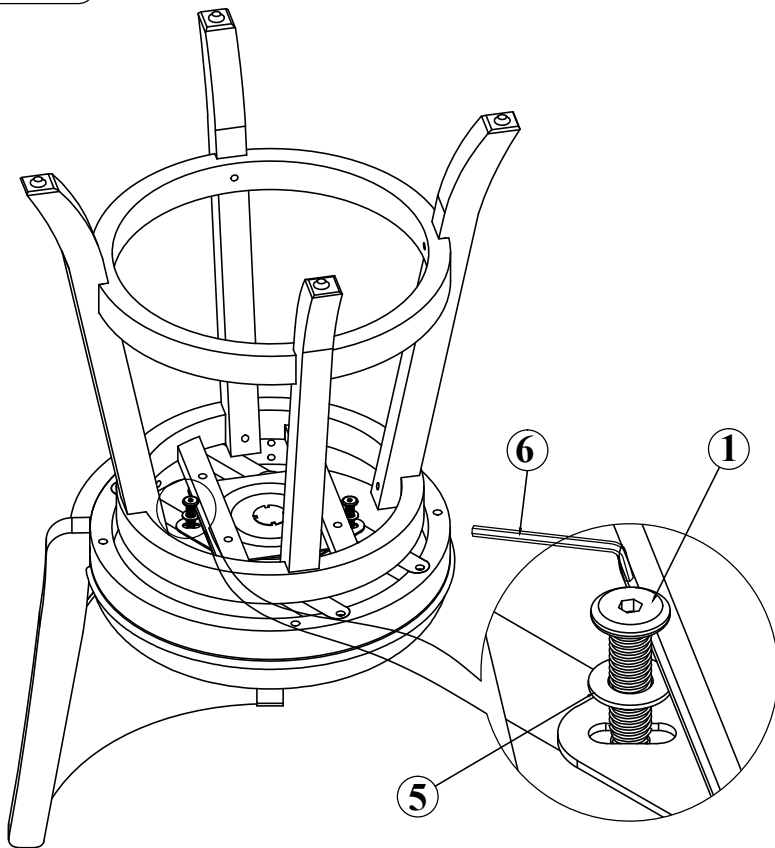

Attach the assembled base from step 2 to the assembled top from Step 3. Insert 4 sets of hardware as shown in the picture. Tighten together after alignment is done.

ASSEMBLY COMPLETE

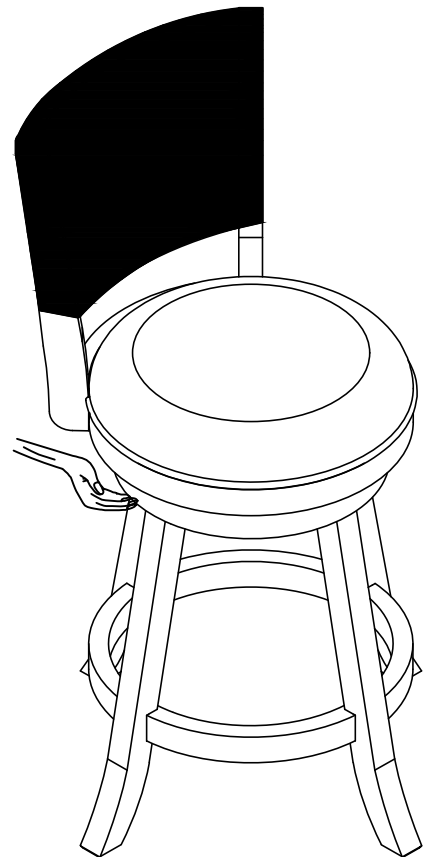

CAUTION: Do not put fingers into seat gap.