

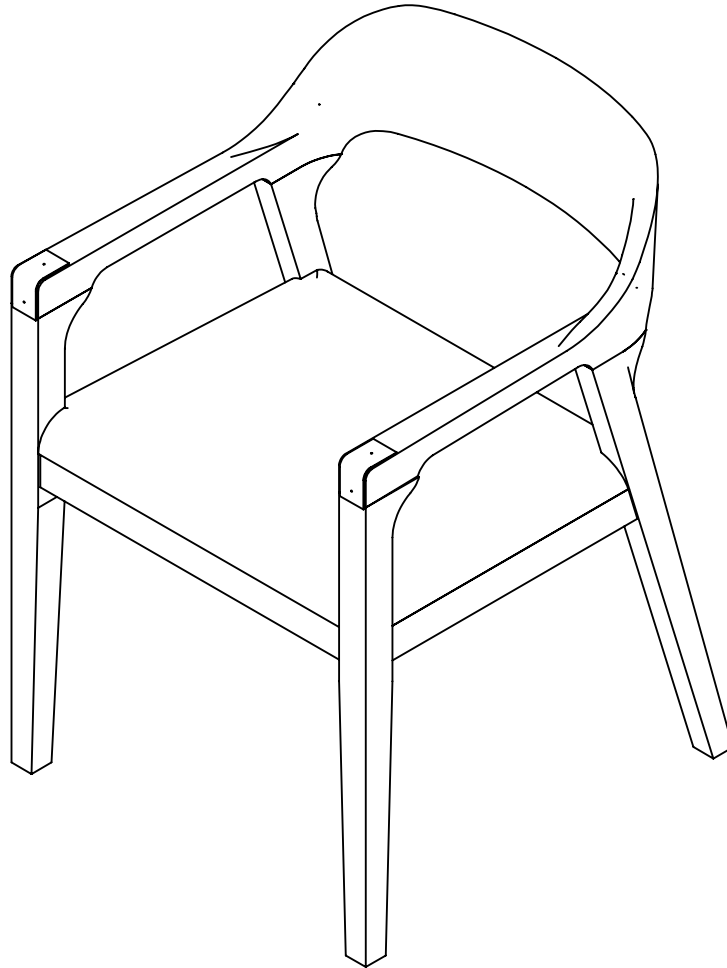

Boraam Industries

ASSEMBLY INSTRUCTIONS

SKU: 77517 | MONTANA DINING ARM CHAIR



Have questions about assembling your item?



Items or parts damaged?



Missing a part?

We're here to help! (Monday-Friday from 9am-5pm CST)



847-949-6300
877-267-2261



customerservice@
boraamindustries.com



www.boraamindustries.com

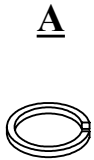

9PCS
M8*10

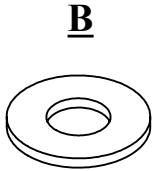

9PCS
M8*19

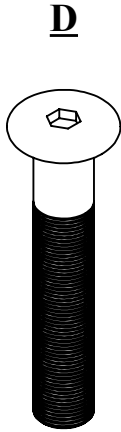

7PCS
M8*45

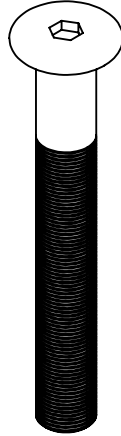

4PCS
M8*60

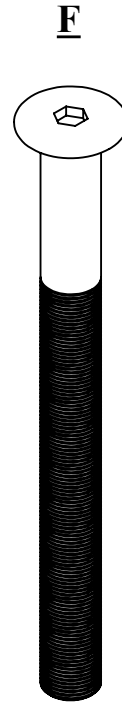

2PCS
M8*95

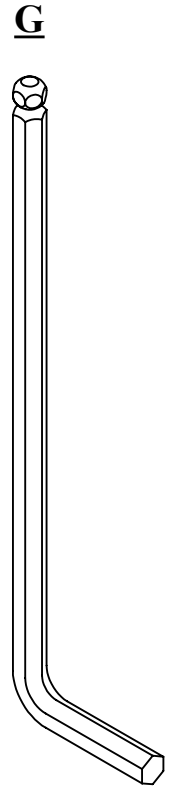

1PC
Allen Wrench
M4*110

1

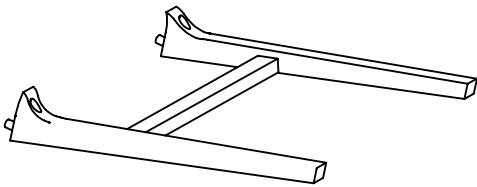

2

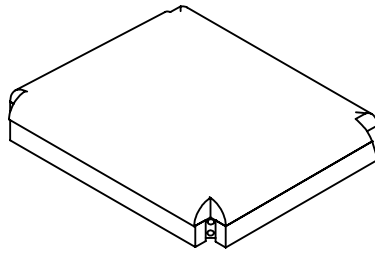

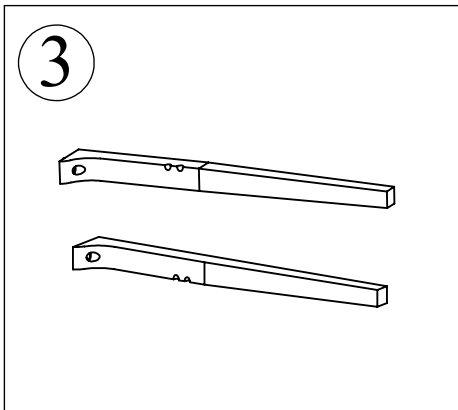

3

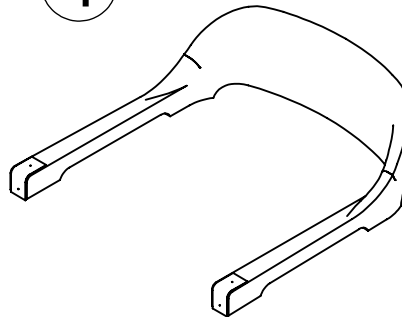

4



01

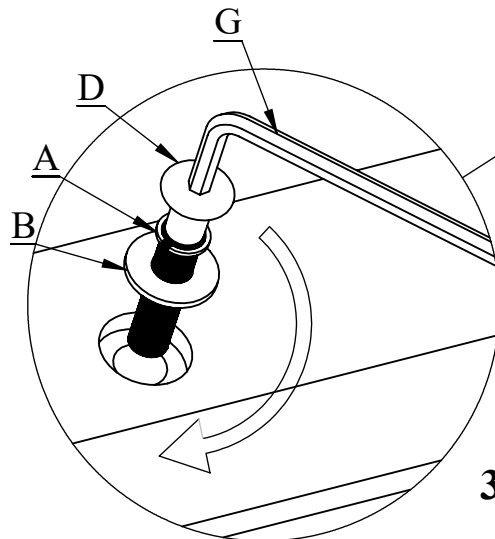
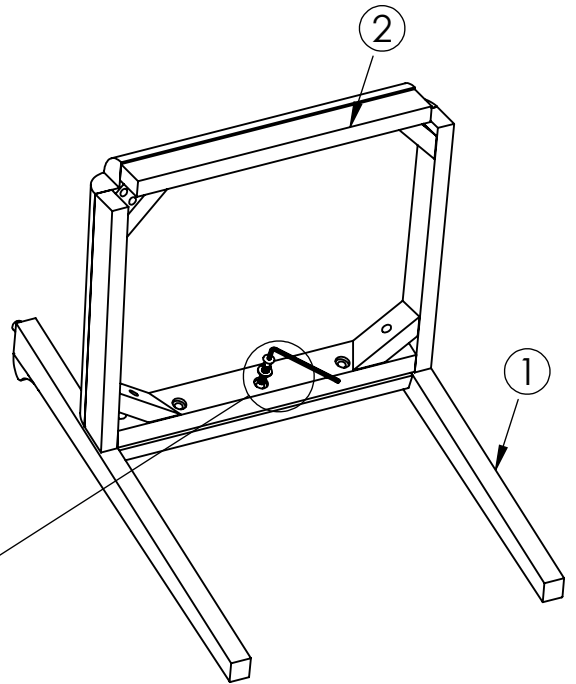

A 	B 	D 
3PCS M8*10	3PCS M8*19	3PCS M8*45



3X

DO NOT TIGHTEN BOLT COMPLETELY

02

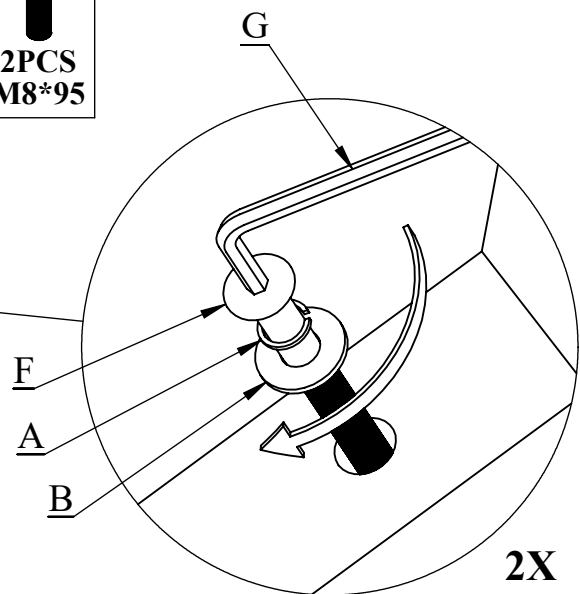
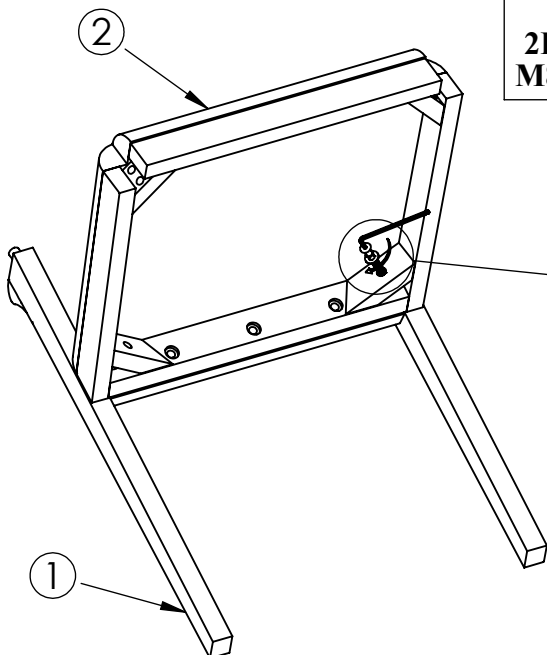

A 	B 	F 
2PCS M8*10	2PCS M8*19	2PCS M8*95



2X

DO NOT TIGHTEN BOLT COMPLETELY

03

A	B	E
		
4PCS M8*10	4PCS M8*19	4PCS M8*60

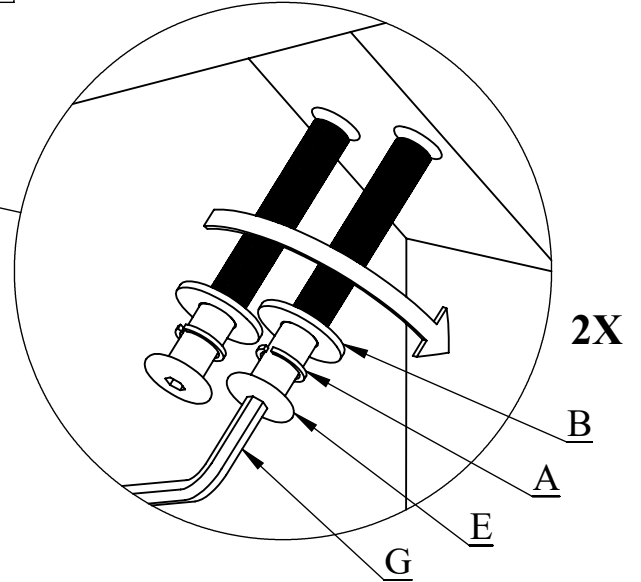
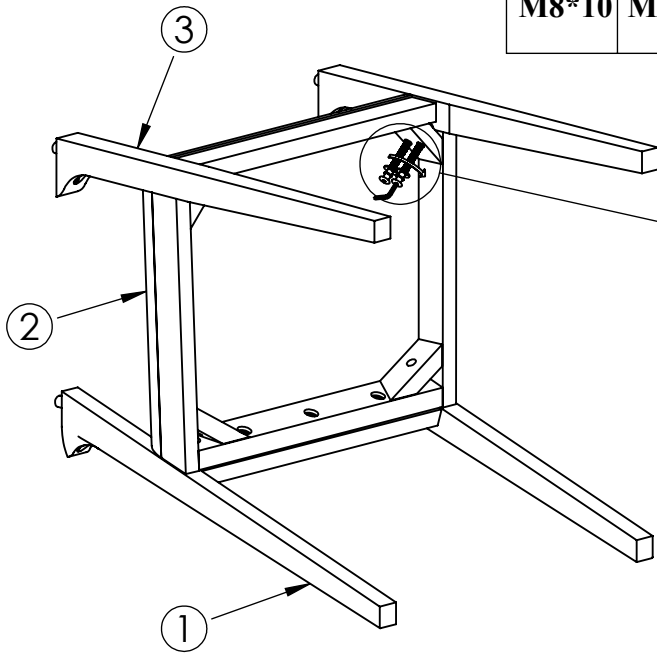

DO NOT TIGHTEN BOLT COMPLETELY

04

D

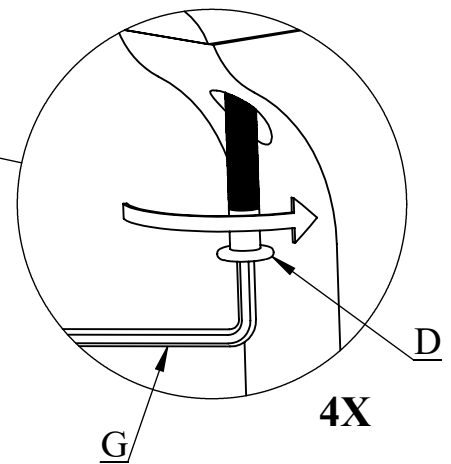
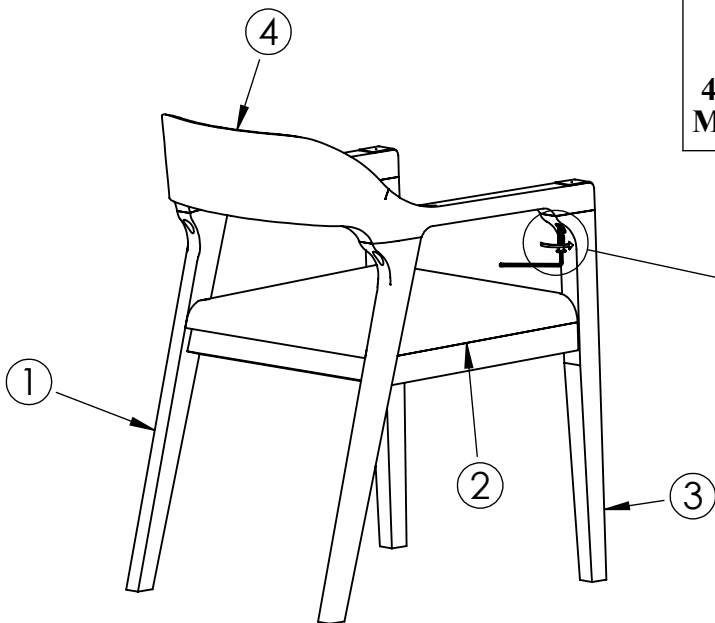
4PCS M8*45

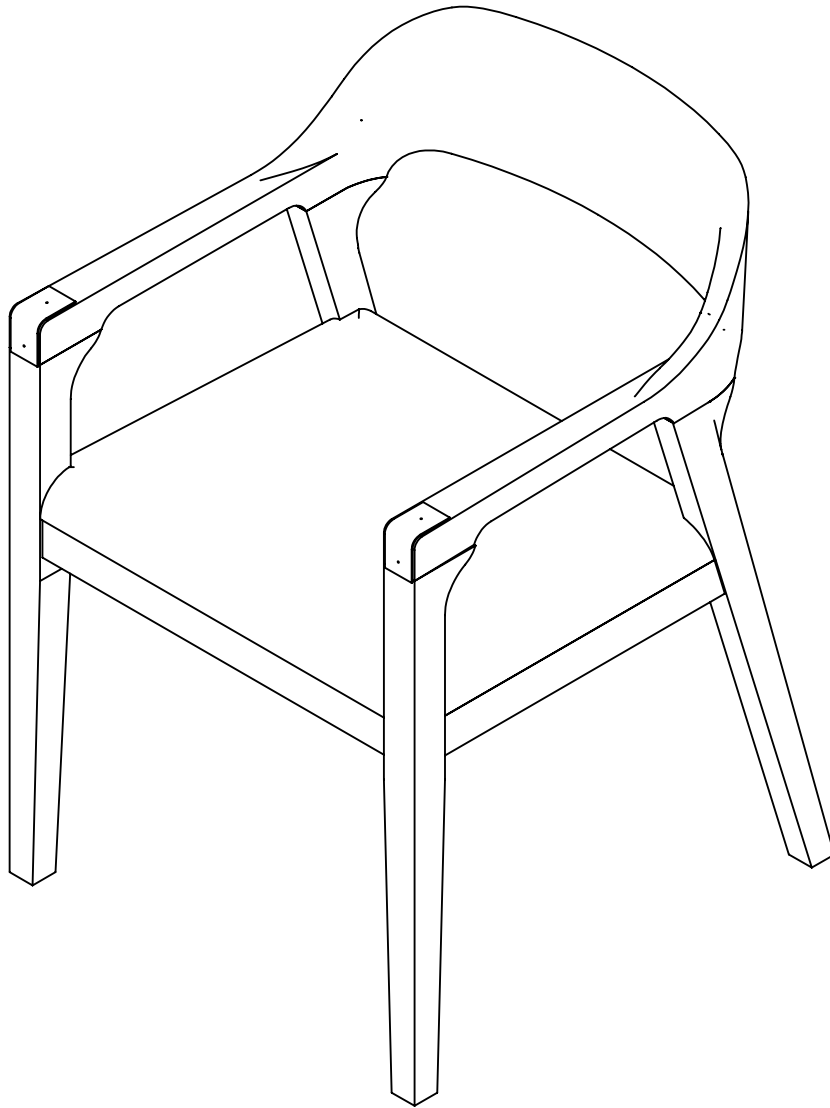

DO NOT TIGHTEN BOLT COMPLETELY



BE SURE TO CHECK ALL BOLTS SECURELY
TIGHTENED PRIOR USING THIS CHAIR

847-949-6300 | 877-267-2261 | customerservice@boraamindustries.com

Page 5 of 5



Boraam Industries

**MONTANA DINING BENCH
ASSEMBLY INSTRUCTIONS**

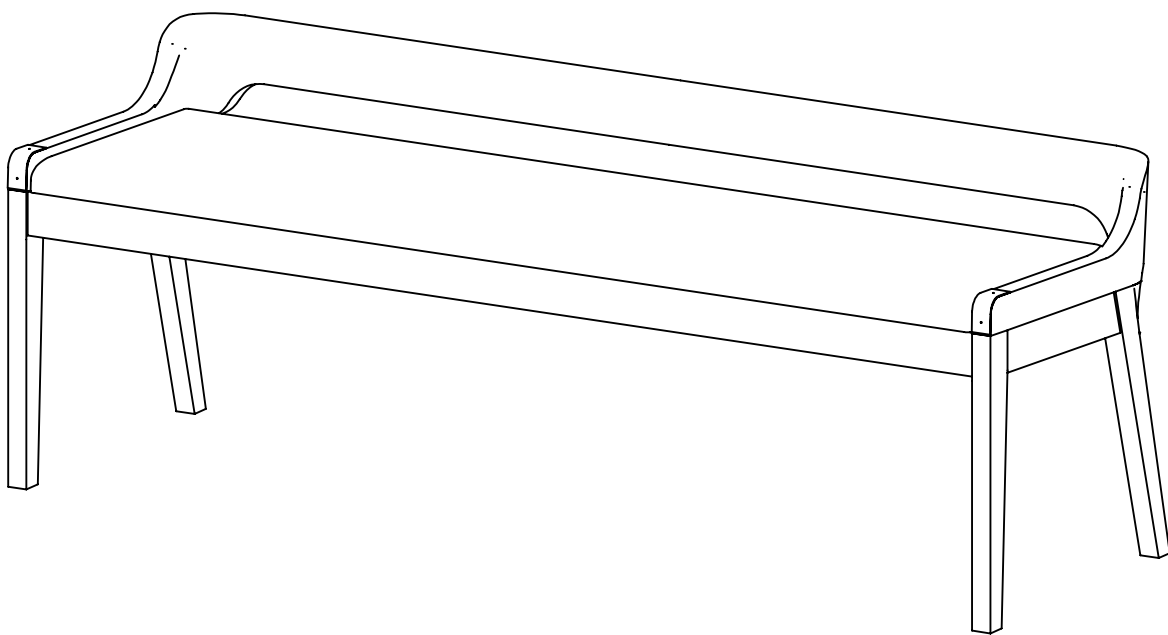



PLEASE READ ME FIRST



- Have questions about assembling your item?



- Item or parts damaged?



- Missing a part?



- We're here to help!



(847)949-6300 (M-F, 9am-5pm CST)



www.boraamindustries.com



customerservice@boraamindustries.com

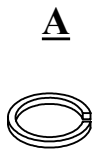

8PCS
M8*10

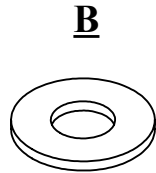

8PCS
M8*19

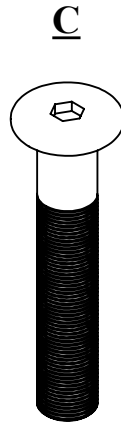

8PCS
M8*45

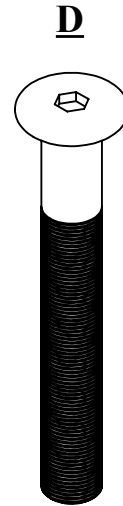

6PCS
M8*60

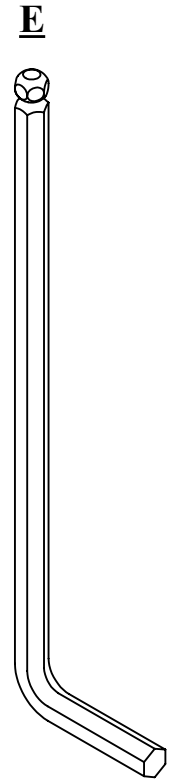

1PC
Allen Wrench
M4*110

①

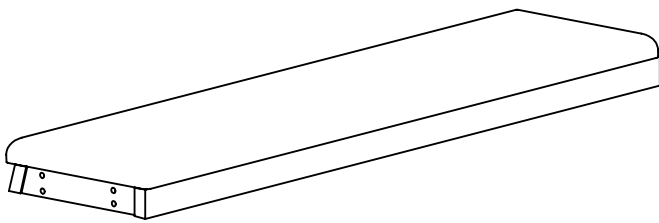

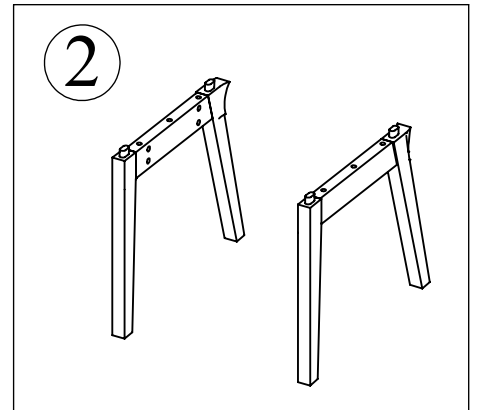

②

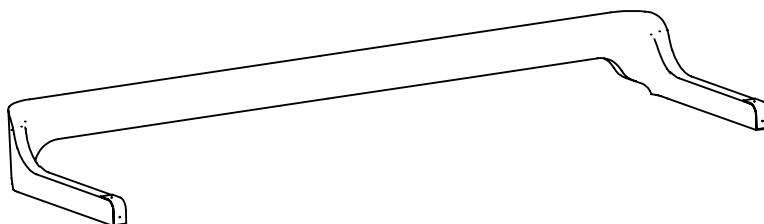

③



01

A 	B 	C 
8PCS M8*10	8PCS M8*19	8PCS M8*45

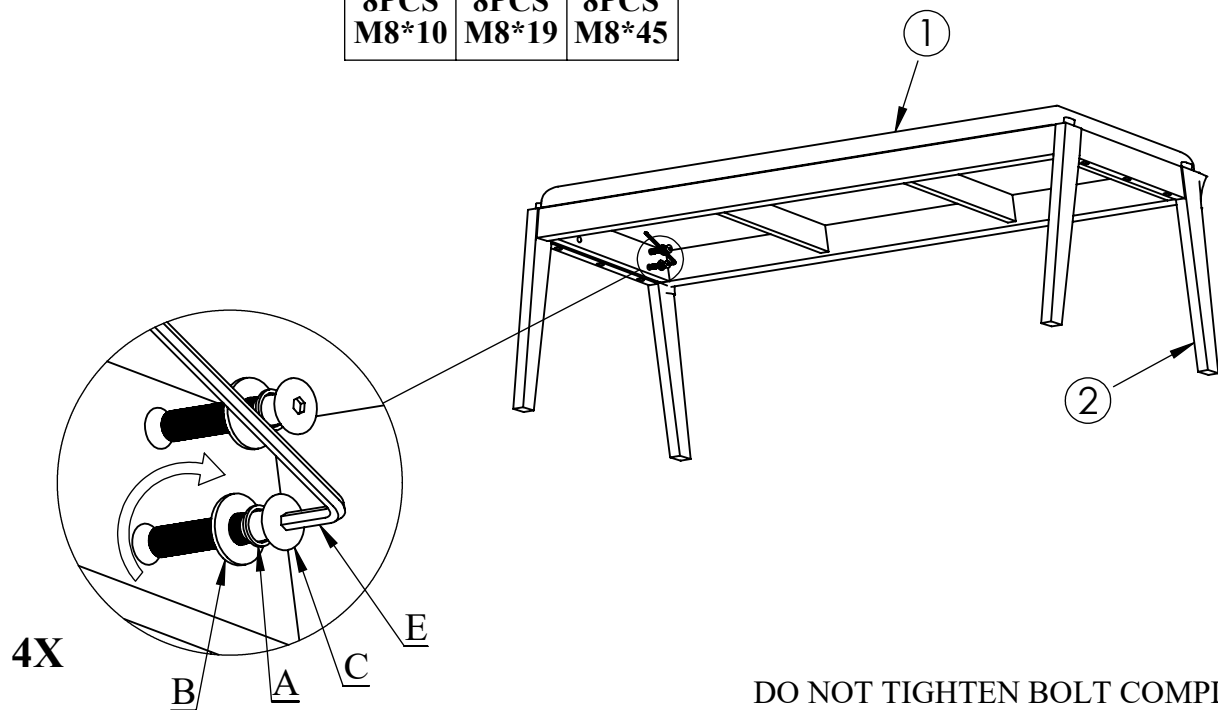

02

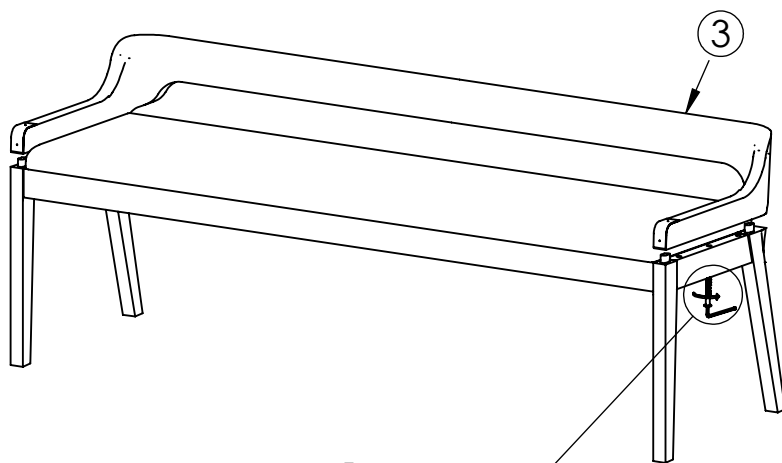

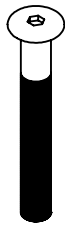
D 
6PCS M8*60

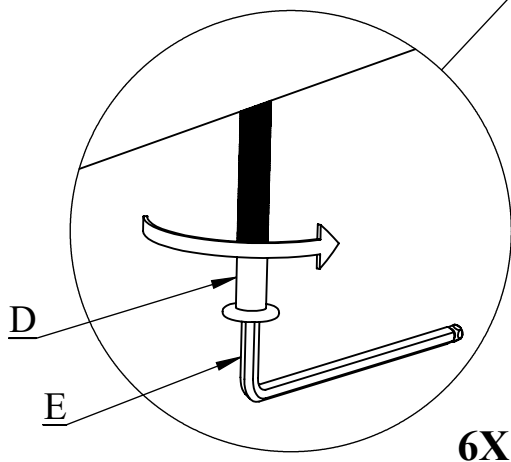

DO NOT TIGHTEN BOLT COMPLETELY

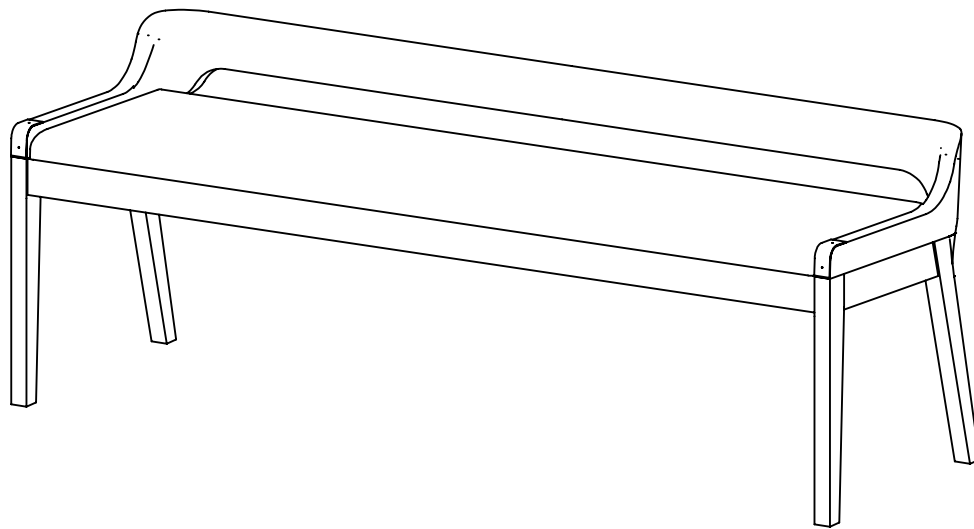

BE SURE TO CHECK ALL BOLTS SECURELY
TIGHTENED PRIOR USING THIS BENCH



Boraam Industries
MONTANA EXTENSION DINING TABLE
ASSEMBLY INSTRUCTIONS

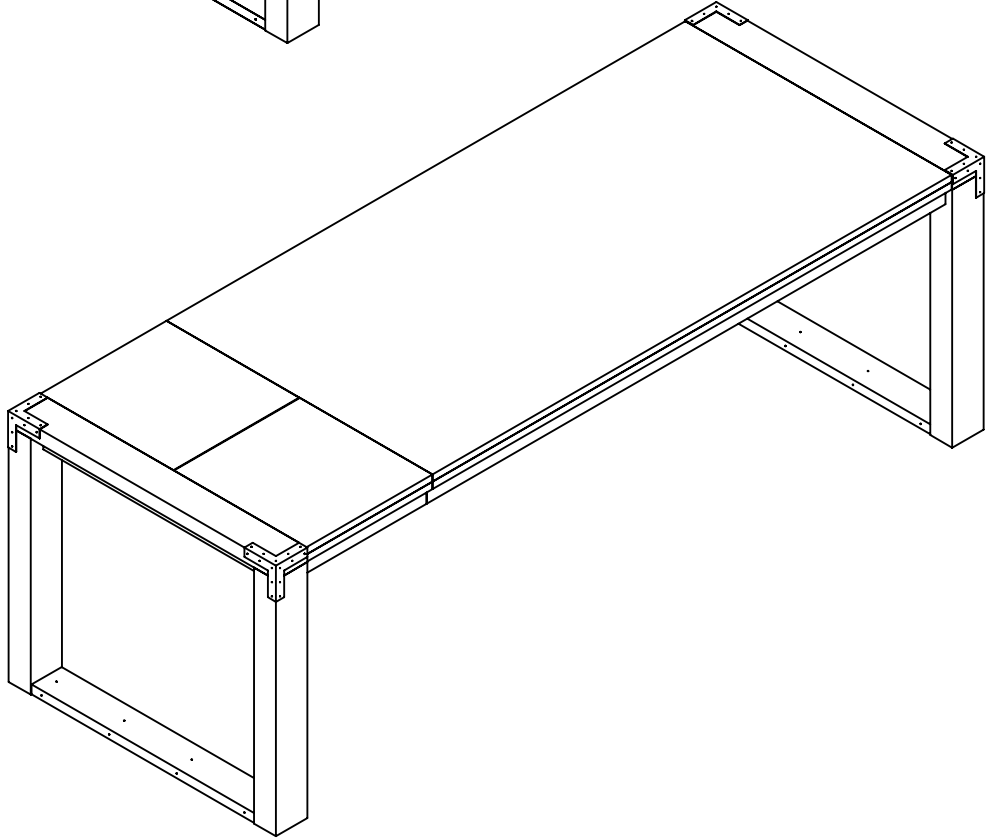
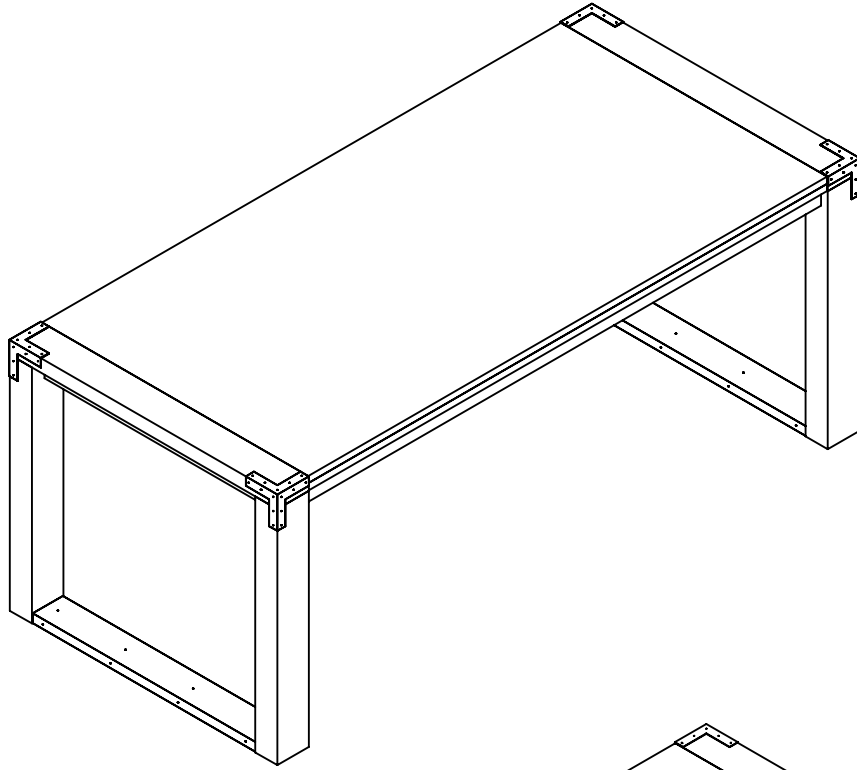



PLEASE READ ME FIRST



- Have questions about assembling your item?



- Item or parts damaged?



- Missing a part?



- We're here to help!



(847)949-6300 (M-F, 9am-5pm CST)



www.boraamindustries.com



customerservice@boraamindustries.com

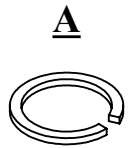

12PCS
M10*10

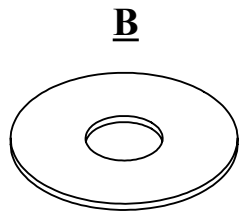

12PCS
M10*30

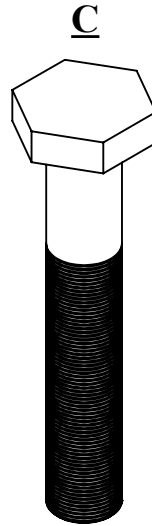

12PCS
M10*60

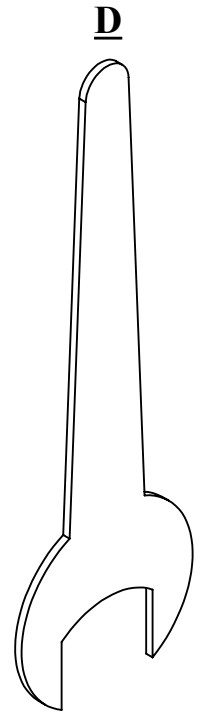

1PC
Allen Wrench
M17*100

①

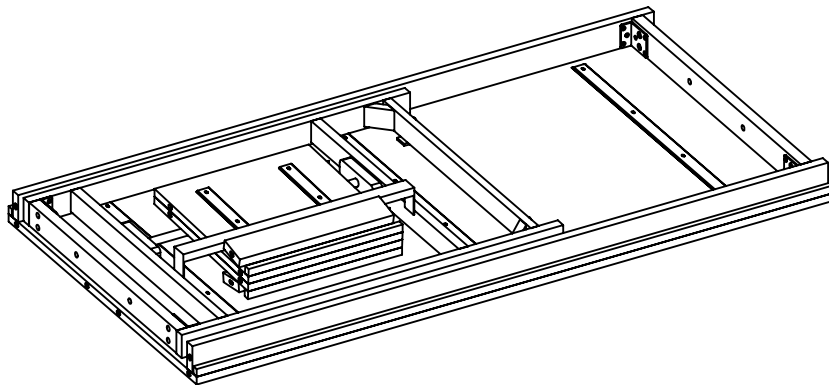

②

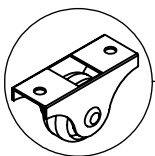
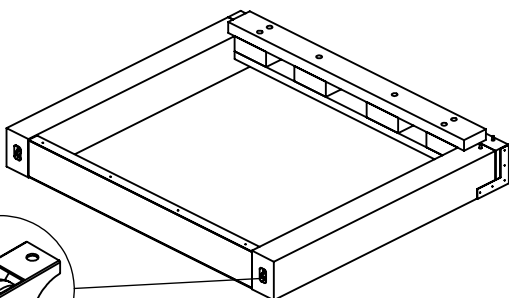

③

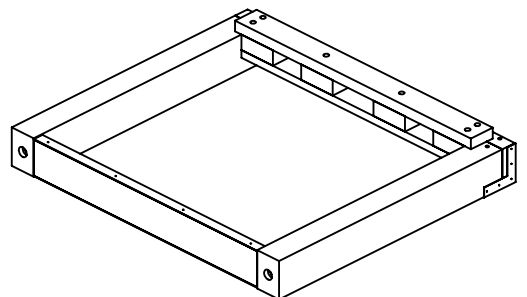

01

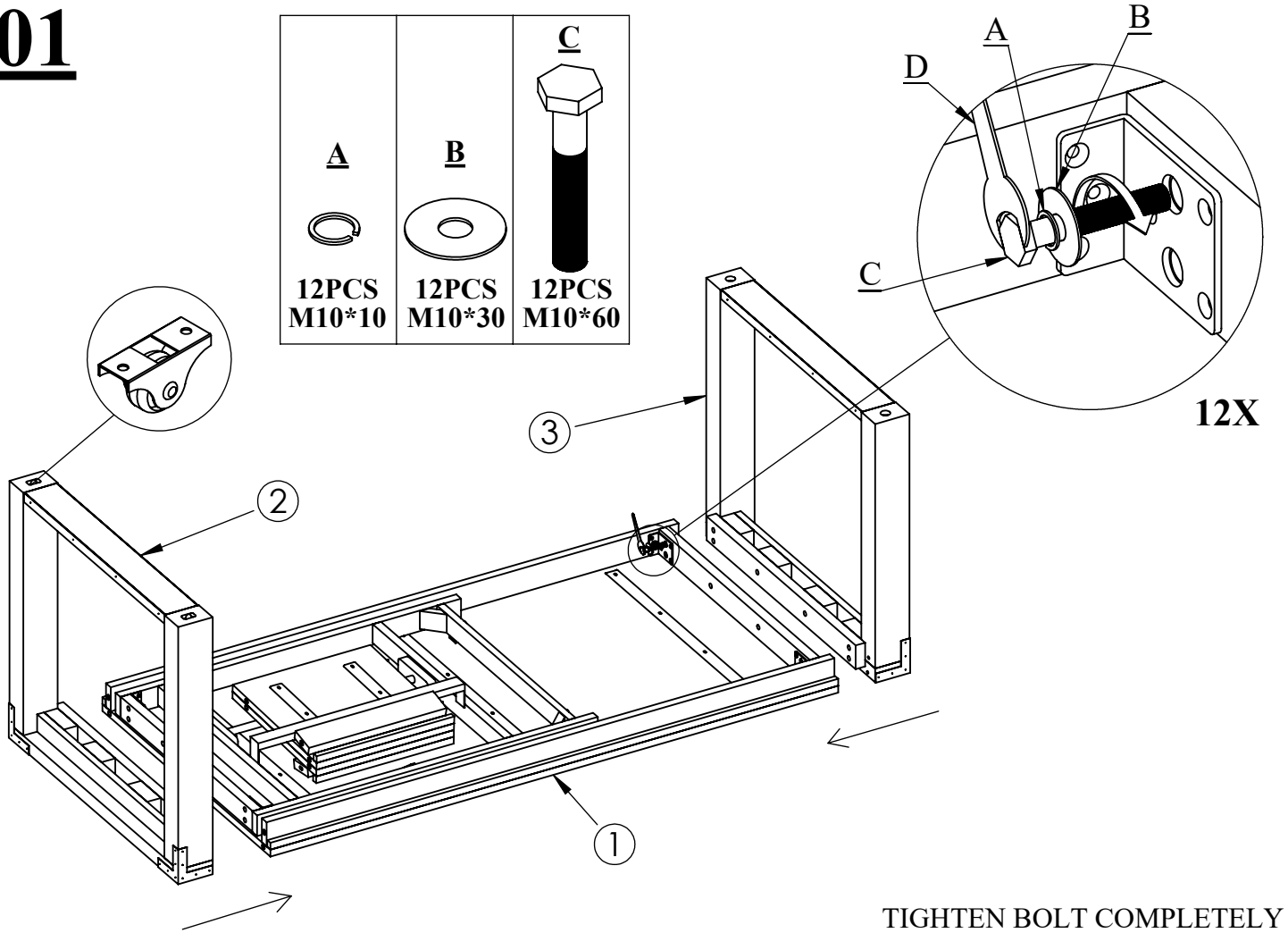

02

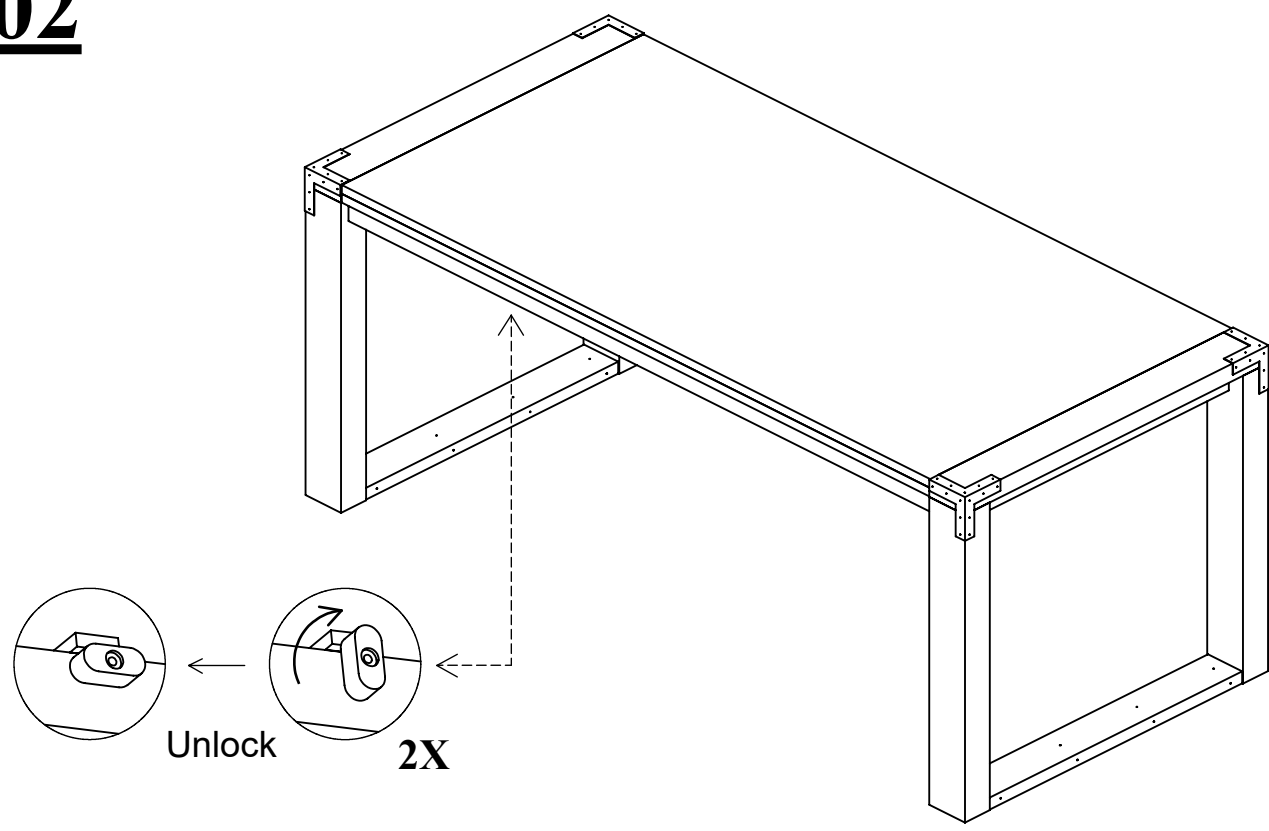

03

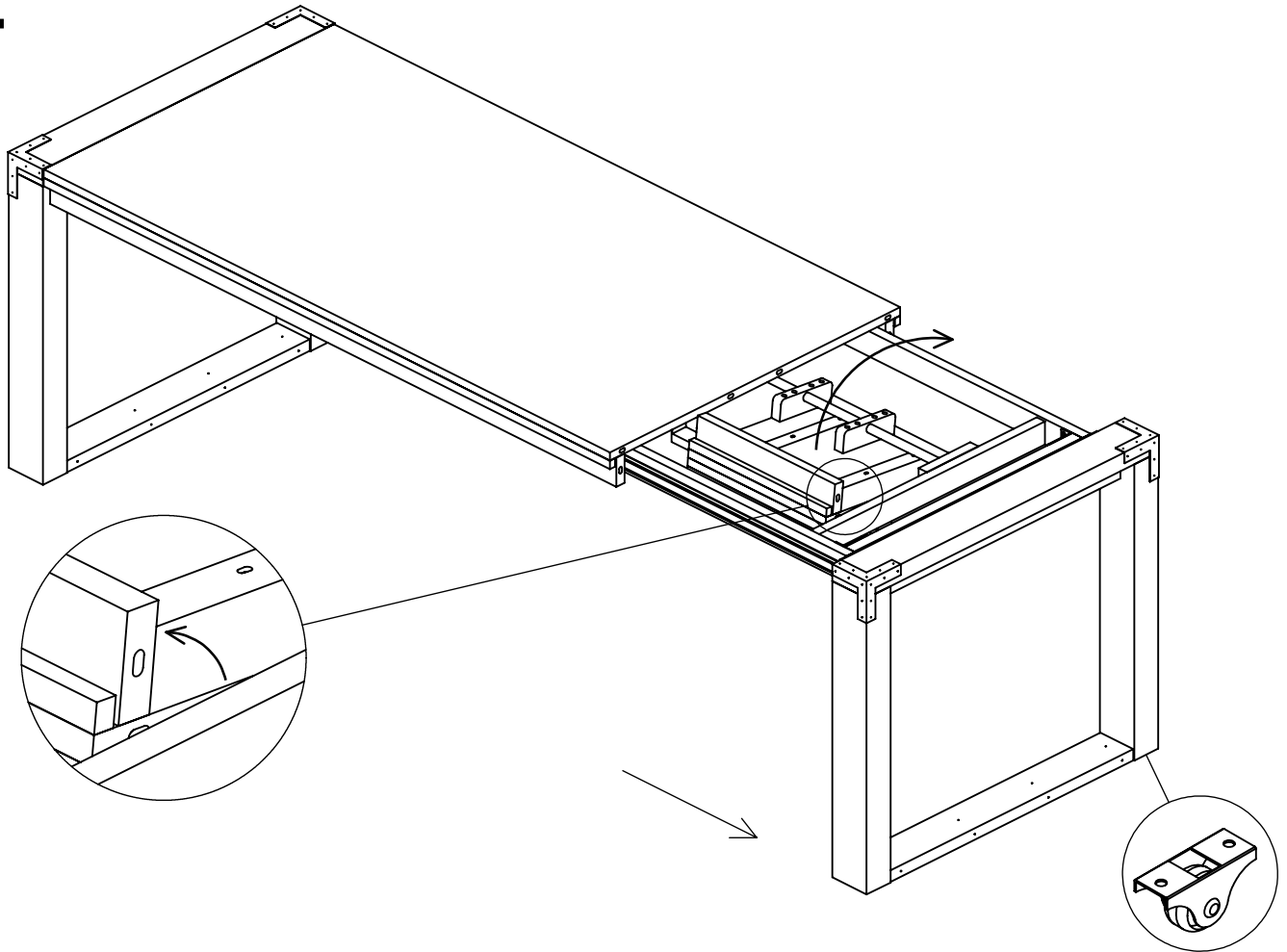

04

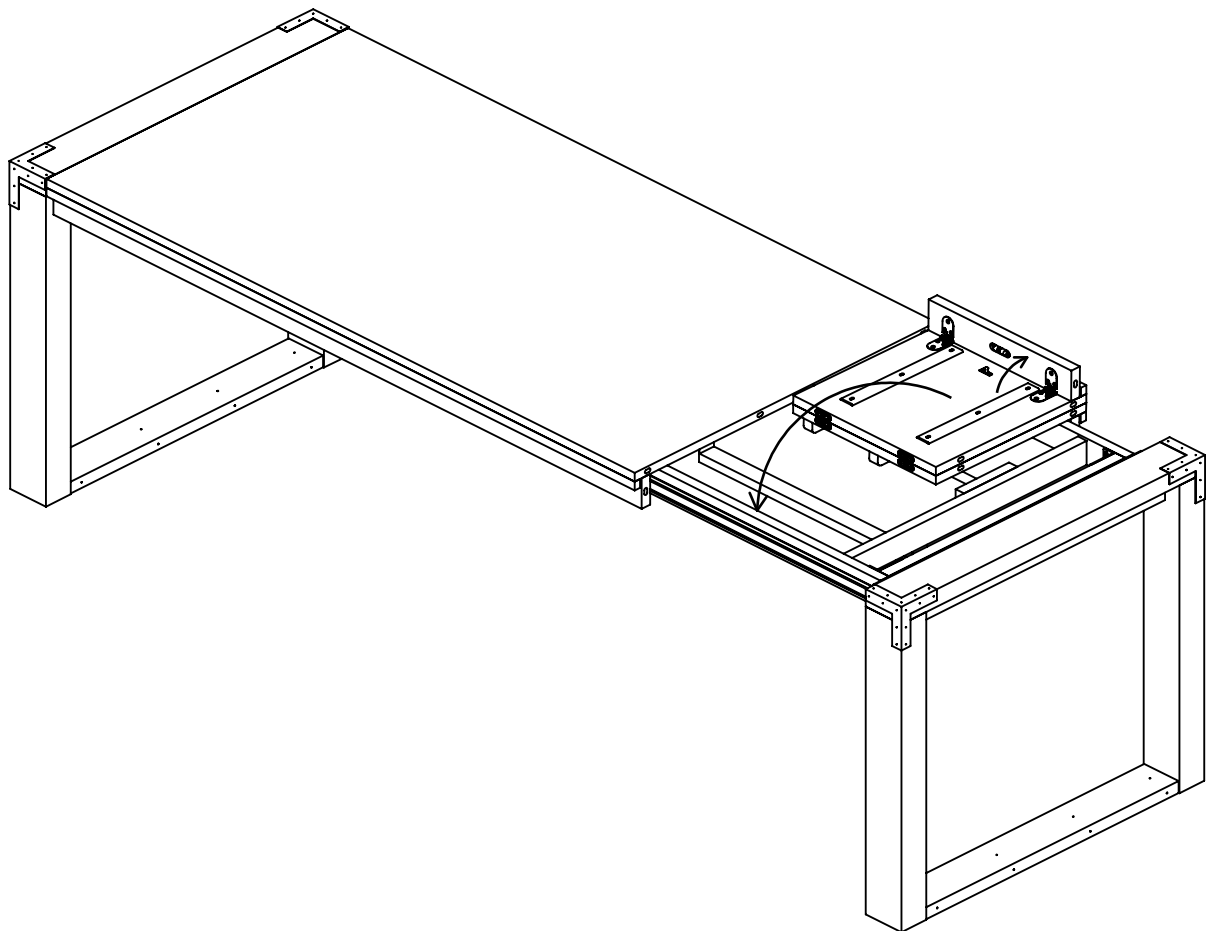

05

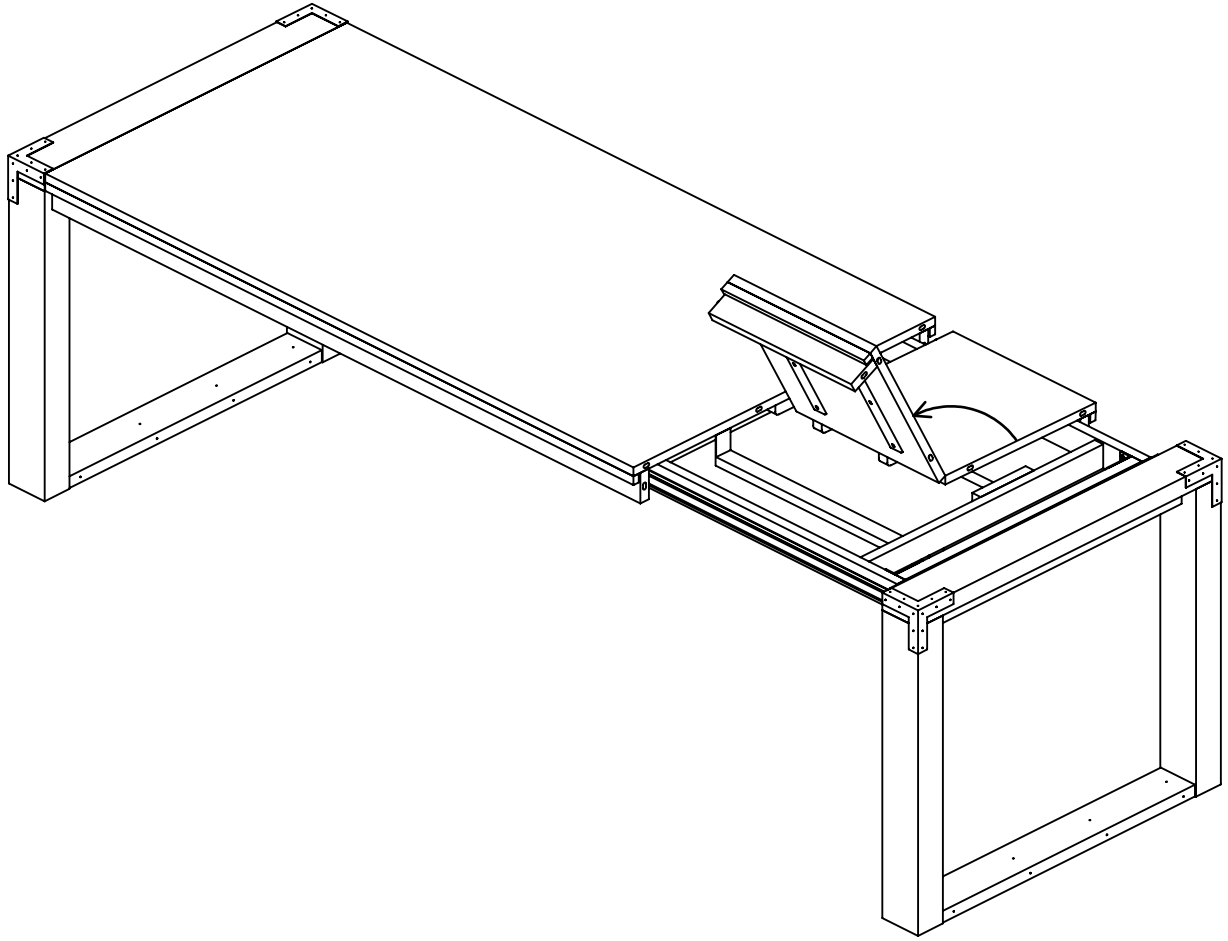

06

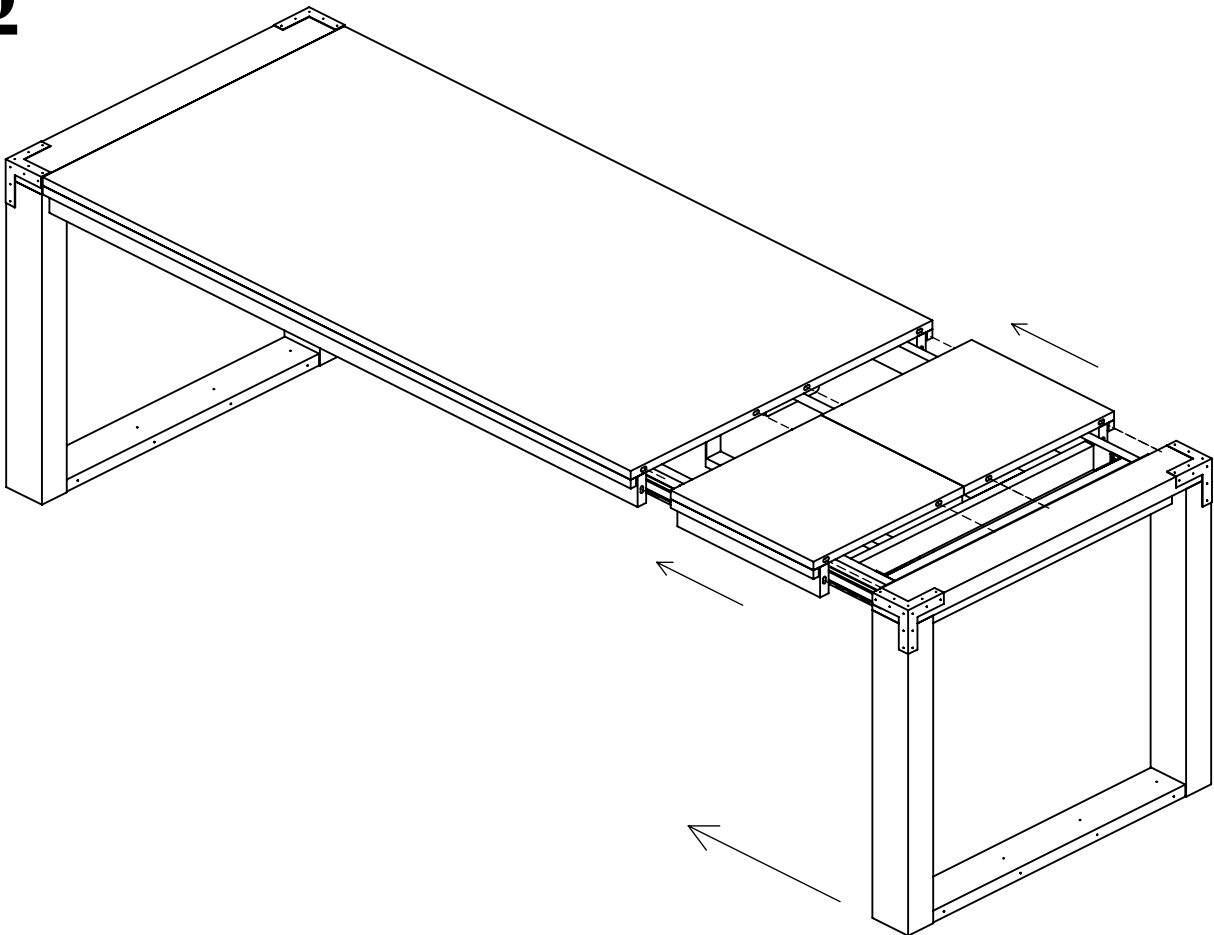

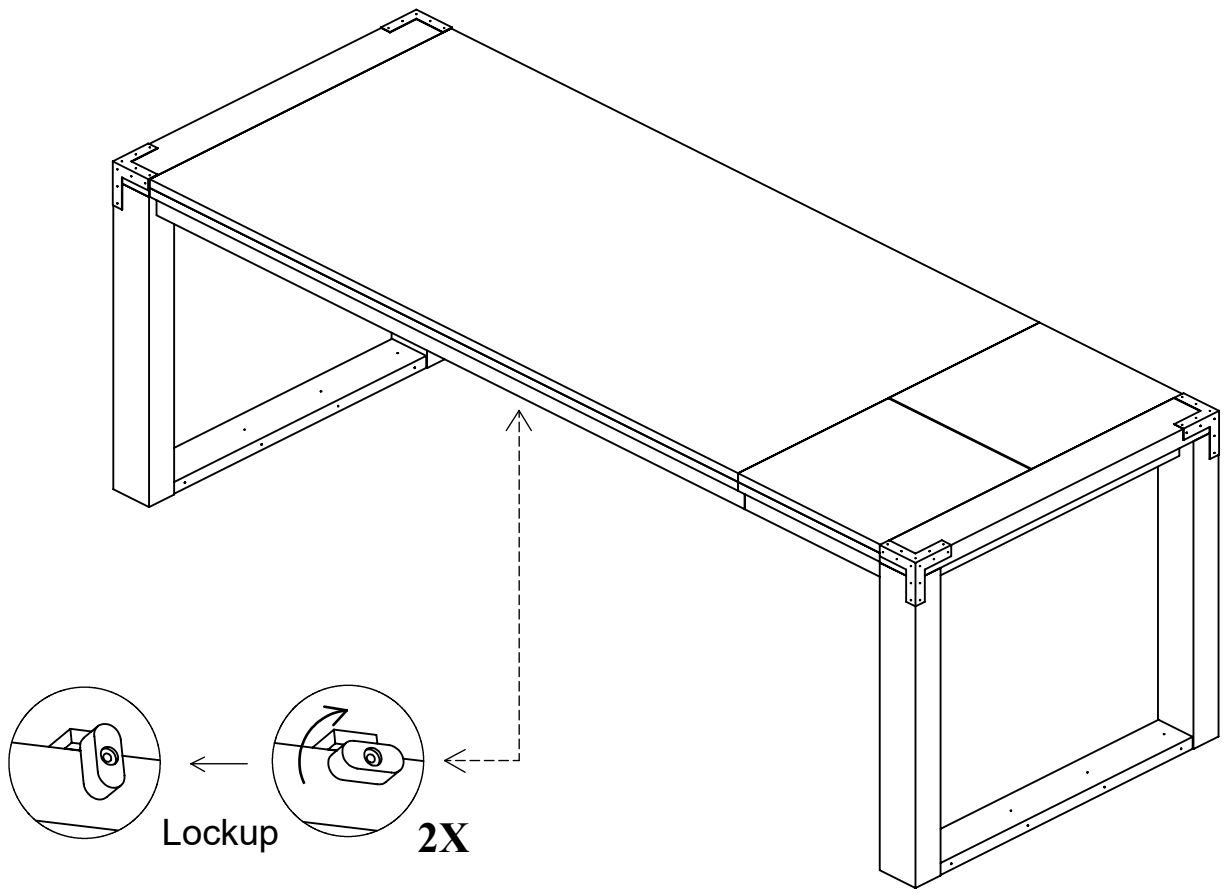

BE SURE TO CHECK ALL BOLTS SECURELY
TIGHTENED PRIOR USING THIS TABLE