



# Boraam Industries

## HONEYMOON TABLE Assembly Instructions

- **Tools Included**
- **Do not throw away packing materials until assembly is complete**
- **Assemble this item on a soft, clean surface to protect the product**
- **Proper assembly requires 2 People**
- **Make sure all parts are included prior to assembly**

PART LIST		
NO.	DESCRIPTION	QTY
A	TableTop	1
B	Left Leg	1
C	Right Leg	1
D	Wall leg	1
E	Glass	1

HARDWARE LIST			
NO.	DESCRIPTION	SKETCH	QTY
1	Bolt M8x50mm		10
2	Flat Washer		10
3	Spring Washer M6x10mm		10
4	Allen Wrench M4		1

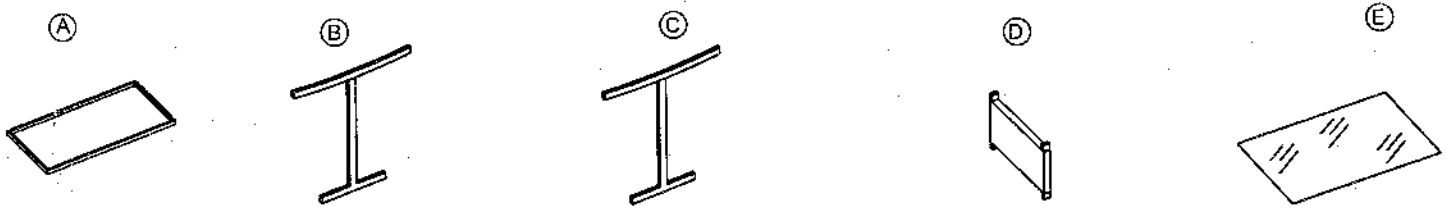

### Step 1

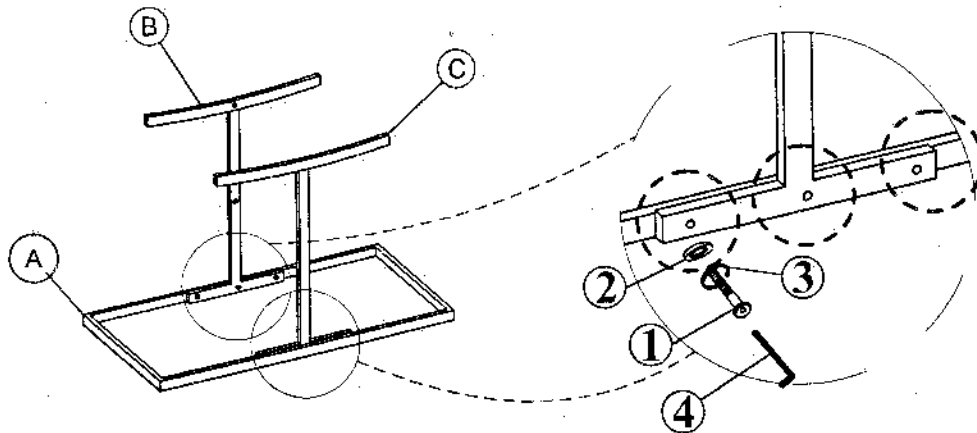

-Prepare ten sets of assembly hardware as shown in the inset drawing- (1ea. Bolt, Spring Washer, and Flat Washer).

-Locate table top (Part A), and on a soft surface, turn top so that top is upside-down.

-Locate table legs (Parts B & C). Properly identify the outside of both parts by seeing which side does not have threaded holes on vertical portion of leg.

-Arrange table legs so that the inside of both parts (Parts B & C) are facing each other, and secure each to the table top. Use three of the assembly hardware sets by inserting them through the three holes in the top of the table legs and into the corresponding holes in the table top. Loosely screw bolts into table top using the supplied Allen wrench. Do not fully tighten bolts at this time.

### Step 2

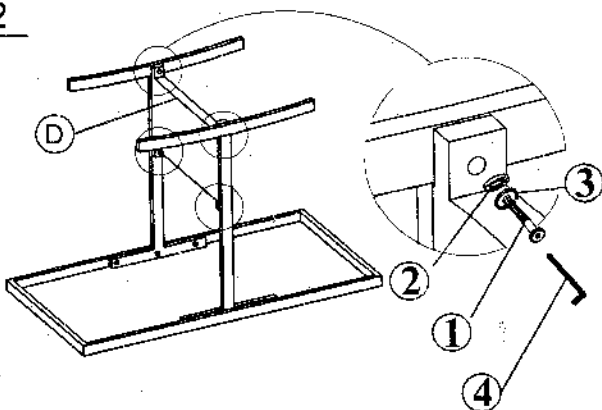

-Locate table leg cross brace (Part D) and align with lower holes in table legs.

-Using four remaining assembly hardware sets, secure cross brace to table legs

### Step 3

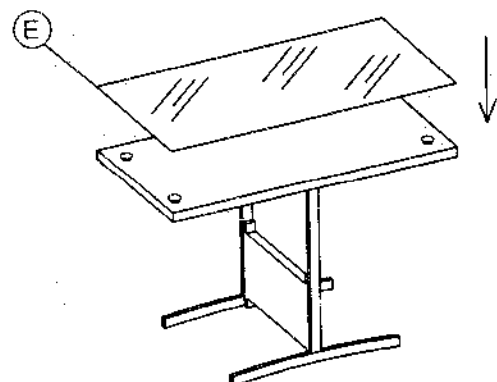

-Using an assistant, turn table assembly upright.

-Locate glass table top, and with assistant place glass on top of table.



# Boraam Industries

## HONEYMOON CHAIR Assembly Instructions

- **Tools Included**
- **Do not throw away packing materials until assembly is complete**
- **Assemble this item on a soft, clean surface to protect the product**
- **Proper assembly requires 2 People**
- **Make sure all parts are included prior to assembly**

PART LIST		
NO.	DESCRIPTION	QTY
A	Back	1
B	Left Arm	1
C	Right Arm	1
D	Backrest	1
E	Seat	1

HARDWARE LIST			
NO	DESCRIPTION	SKETCH	QTY
1	Bolt M6x25mm		8
2	Flat Washer 1/4" x 16mm		8
3	Spring Washer M6x10mm		8
4	Allen Wrench M4		1

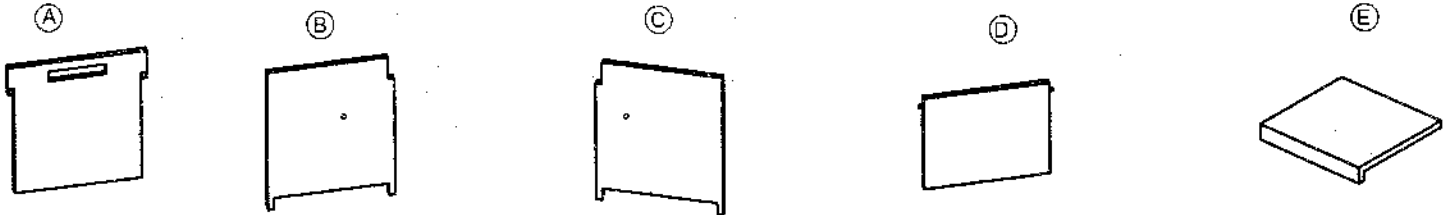

### Step 1

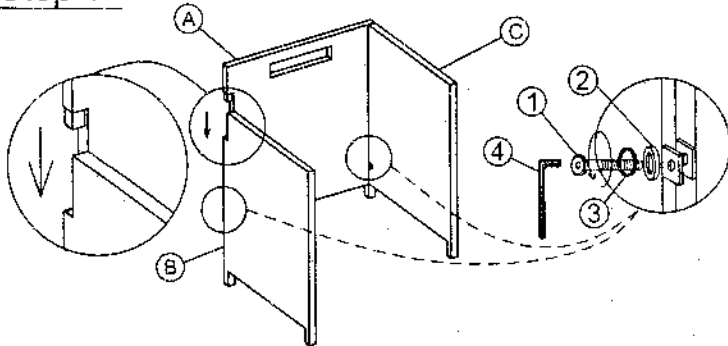

- Prepare eight sets of assembly hardware as shown in the inset drawing (1ea. Bolt, Spring Washer, and Flat Washer).
- Slide sides of chair (Parts B & C) into back of chair (Part A), making sure that metal frame extensions in Part A are inserted into openings on Parts B & C.
- Use two assembly hardware sets to secure Parts B & C to Part A using supplied Allen wrench.
- Do not fully tighten at this point.

### Step 2

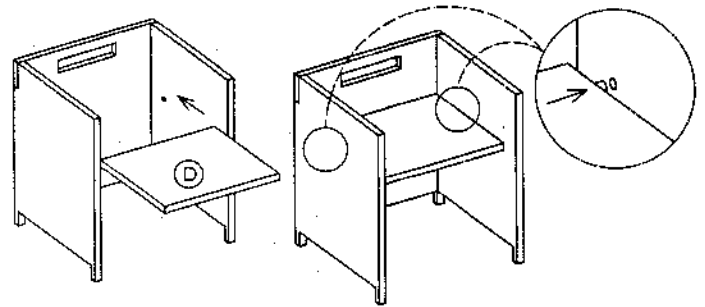

- Locate chair backrest (Part D) and turn part so that alignment pins in part are closer to rear of the chair assembly from Step 1.
- Insert alignment pins in Part D into holes on sides of chair- Parts B & C.

### Step 3

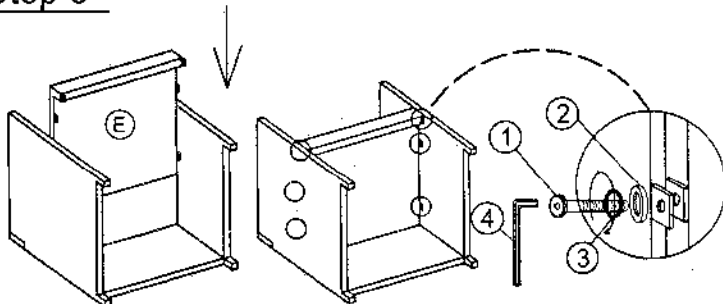

- Lay chair on floor so that back of chair (Part B) is flat on the floor.
- Located chair seat (Part E) and slide part between sides of chair (Parts B & C), ensuring that metal assembly tabs are pointing towards bottom of the chair.
- Using the six remaining assembly hardware sets from Step 1, secure seat (Part E) to sides of chair (Parts B & C) by threading hardware through each of the

### Step 4

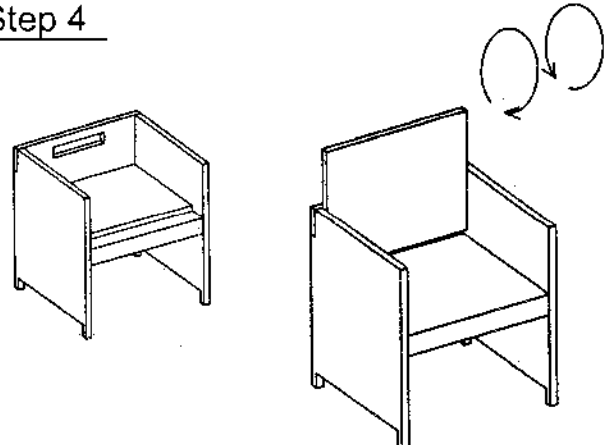

- Turn chair so that it is sitting upright.
- Test chair backrest to ensure that it is able to fold up and down freely