

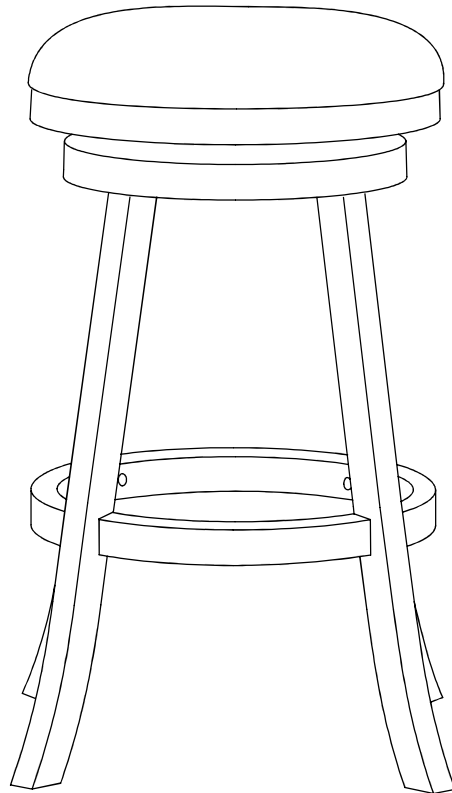

# Boraam Industries

ASSEMBLY INSTRUCTIONS

SKU: 76024,76029,76124,76129 | FENTON SWIVEL STOOL



Weight Capacity



Locate the **HARDWARE PACK** which is attached to the shipping carton with red tape.

01/2024



Have questions about assembling your item?



Items or parts damaged?



Missing a part?

**We're here to help! (Monday-Friday from 9am-5pm CST)**



847-949-6300  
877-267-2261



customerservice@  
boraamindustries.com



www.boraamindustries.com

# Assembly And Care

- All tools required for assembly are included unless noted.
- Prior to assembly, check for missing or damaged parts.
- Do not dispose of packing materials until assembly is completed.
- Assemble item on a soft, clean surface to prevent damage to the item.



Locate the **HARDWARE PACK** which is attached to the shipping carton with red tape.

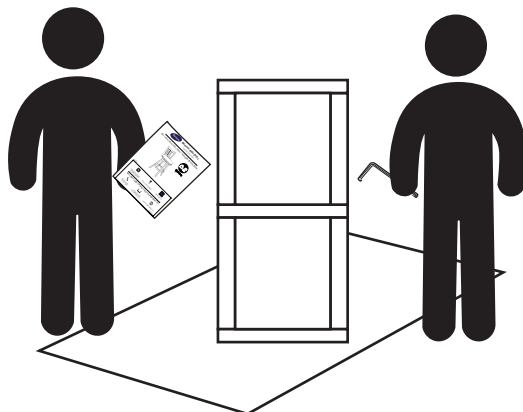
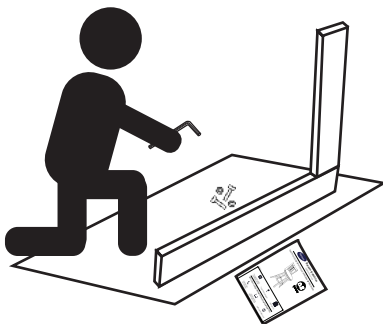
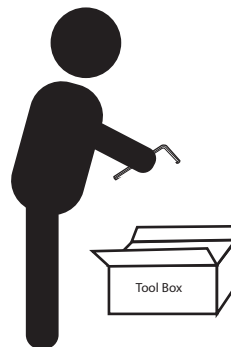
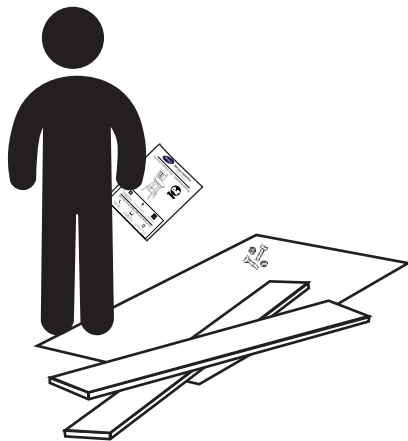

# Assembly Overview

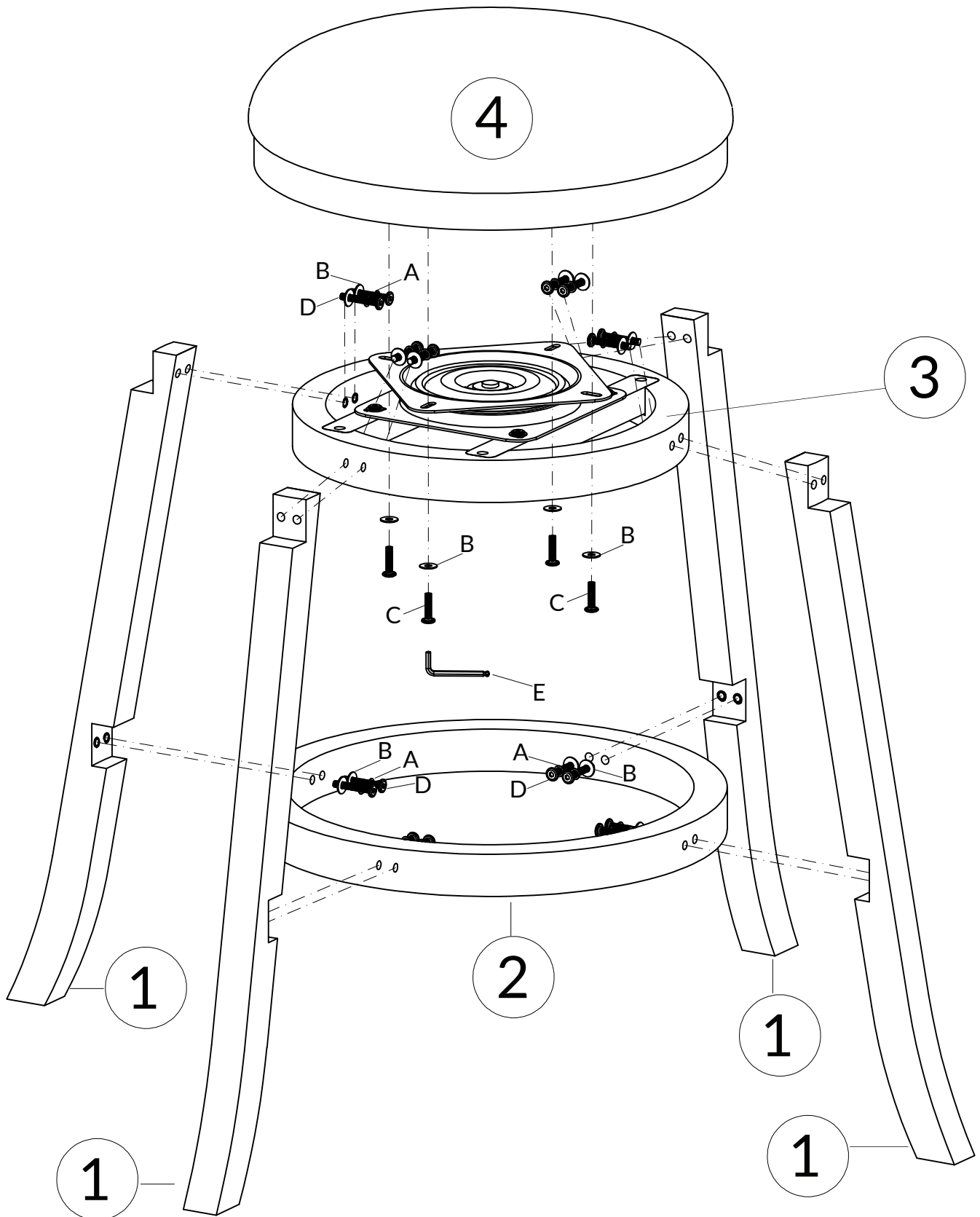

# PARTS

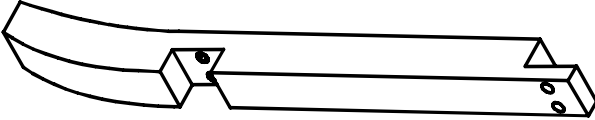
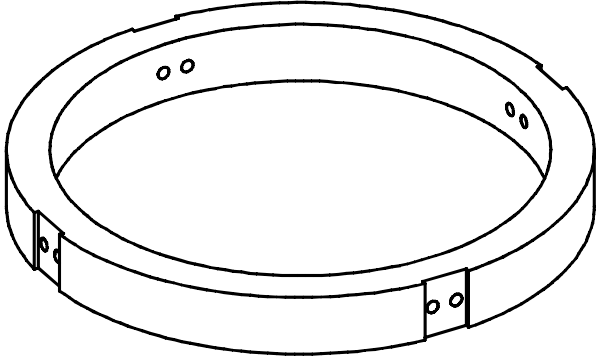
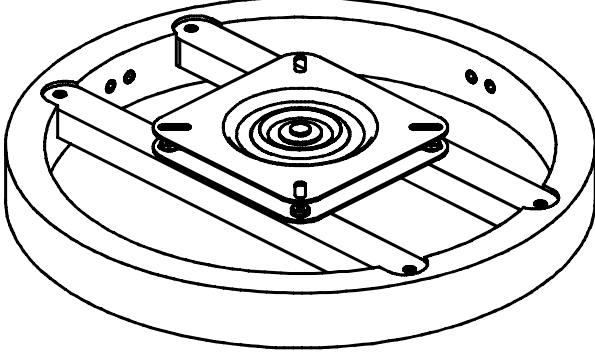
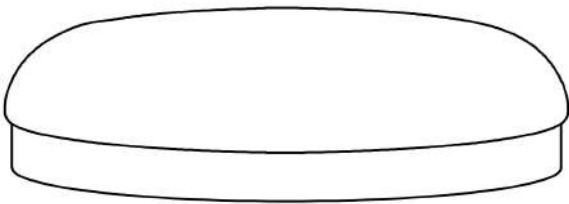
①(x4)	②(x1)
<b>Legs :</b> 	<b>Footrest :</b> 
③(x1)	④(x1)
<b>Apron With Swivel Plate :</b> 	<b>Seat Cushion :</b> 

# HARDWARE

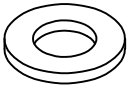
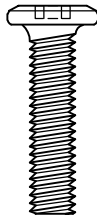
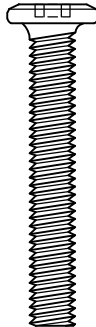
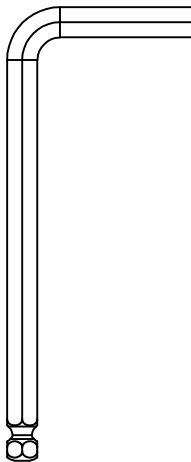
Ⓐ(x16)	Ⓑ(x20)	Ⓒ(x4)	Ⓓ(x16)	Ⓔ(x1)
				
Spring Washer M6*10	Flat Washer M6*16	Bolt M6*25	Bolt M6*40	Allen Wrench M4*110

847-949-6300 | 877-267-2261 | [customerservice@boraamindustries.com](mailto:customerservice@boraamindustries.com)

# 01

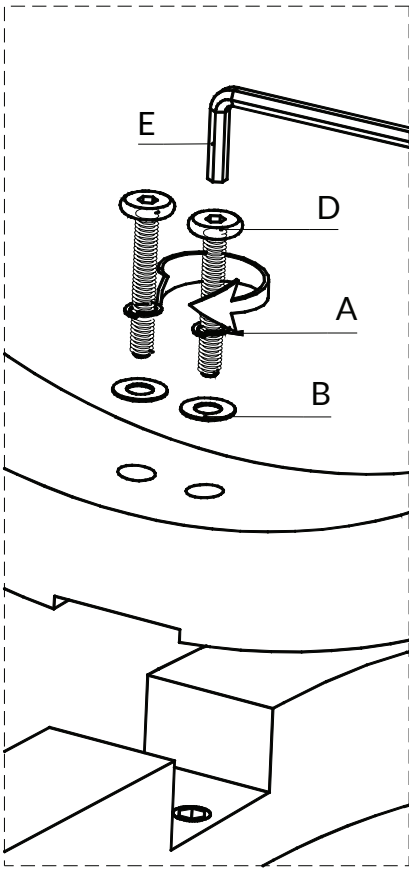

4X

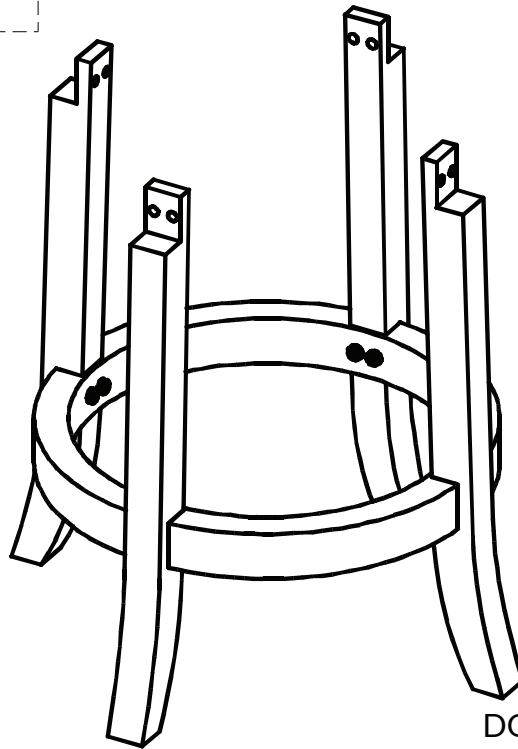
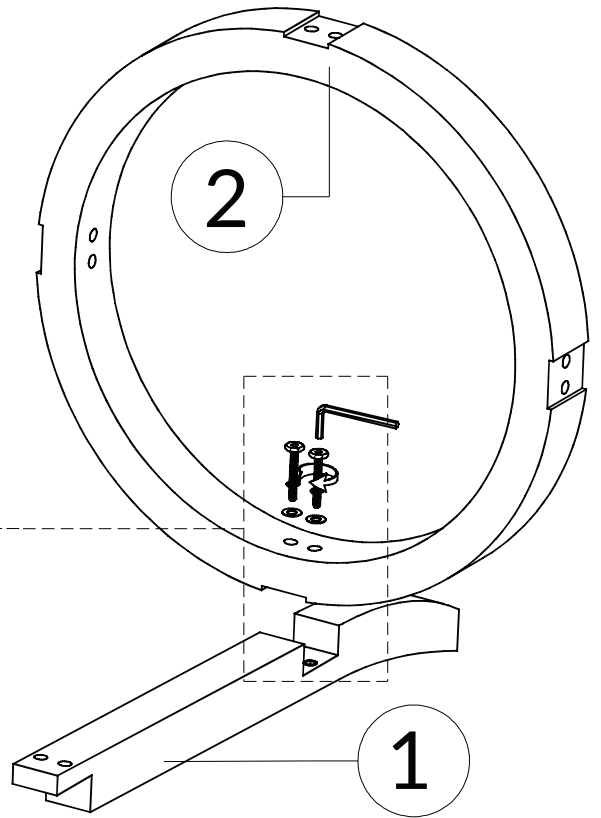

Hardware	Count
A	8
B	8
D	8
E	1

DO NOT TIGHTEN BOLT COMPLETELY.

Please make sure that the protective metal kick plate from Footrest (Part #2) is facing upwards.  
Remove the white Tape from the protective metal kick plate before using.

# 02

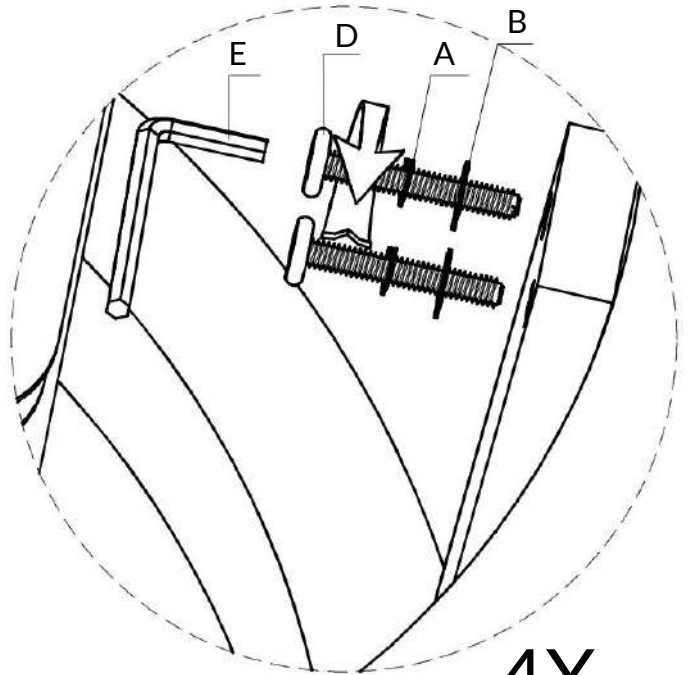
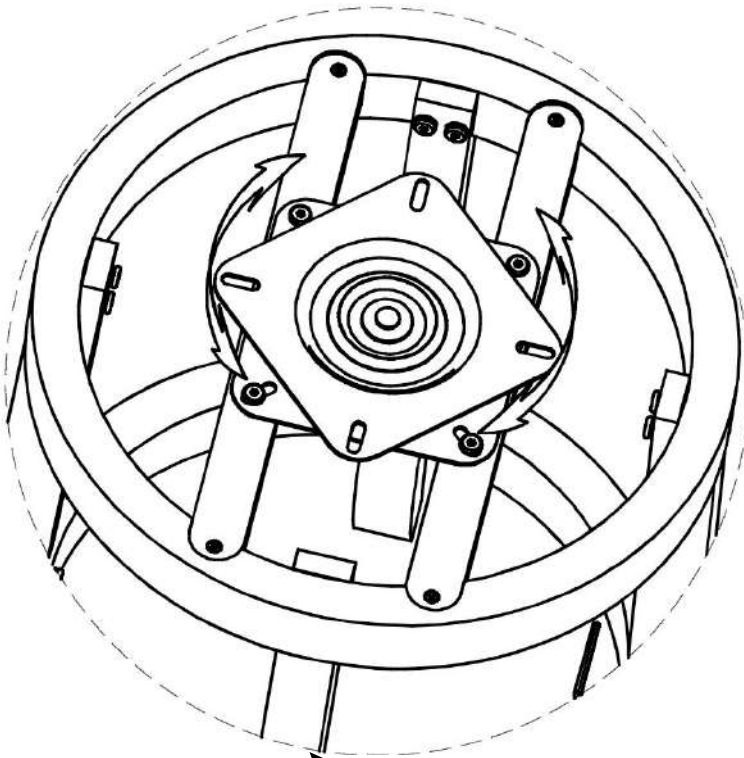

4X

3

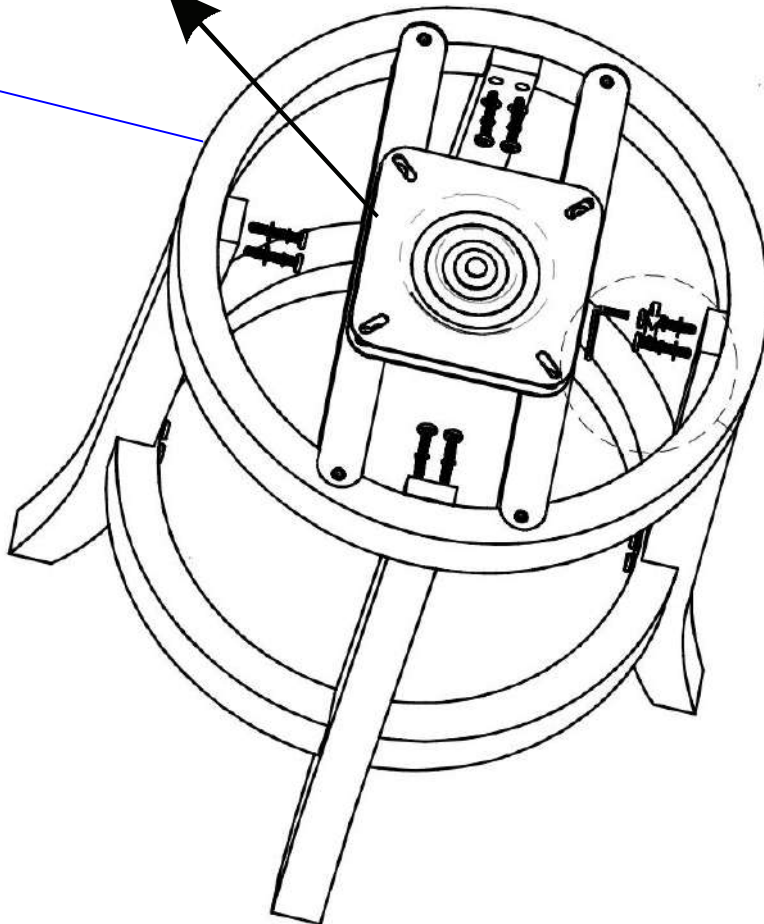

Hardware	Count
A	8
B	8
D	8
E	1

TIGHTEN BOLT COMPLETELY.

# 03

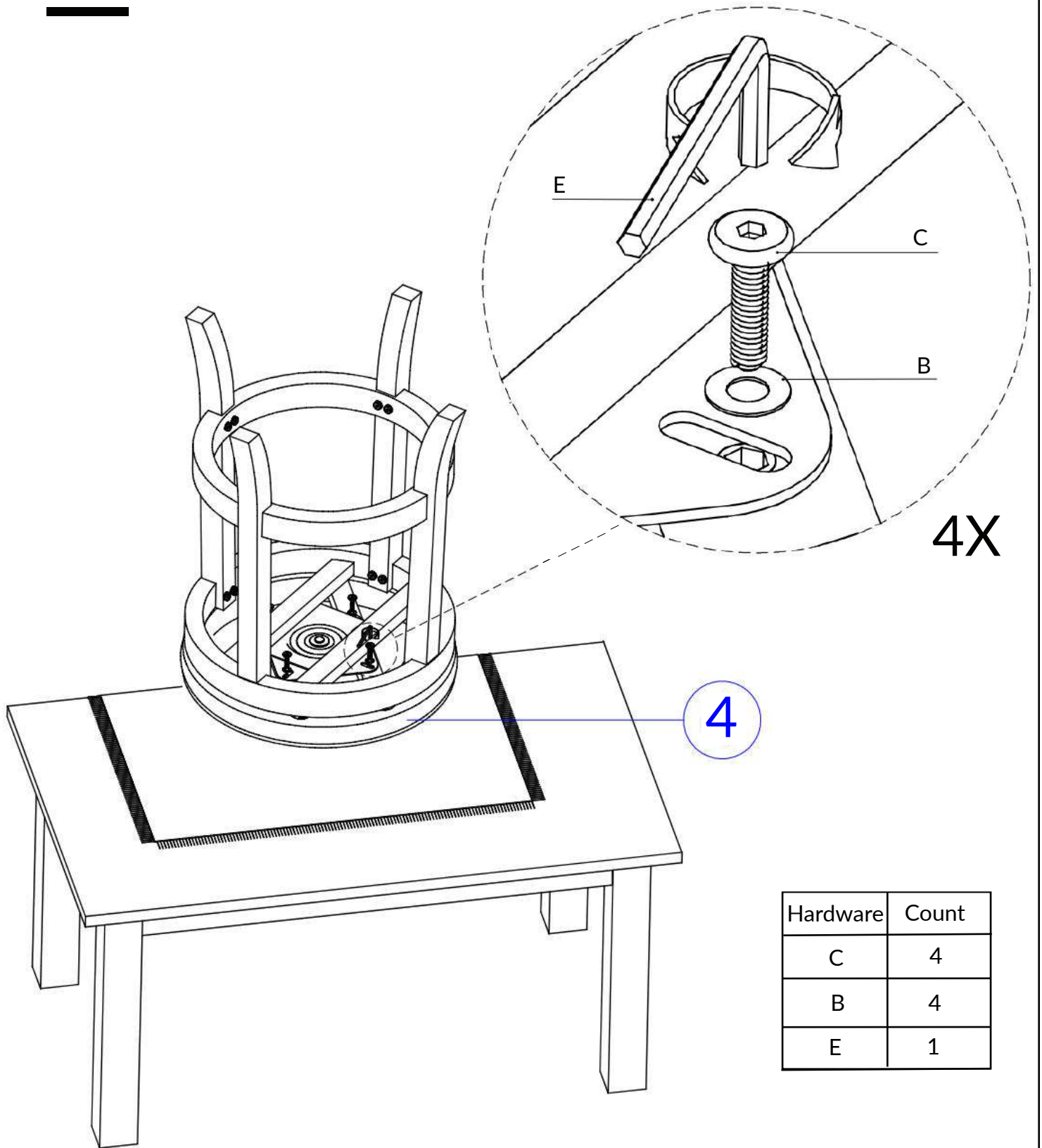

Hardware	Count
C	4
B	4
E	1

TIGHTEN BOLT COMPLETELY.



**Weight Capacity**

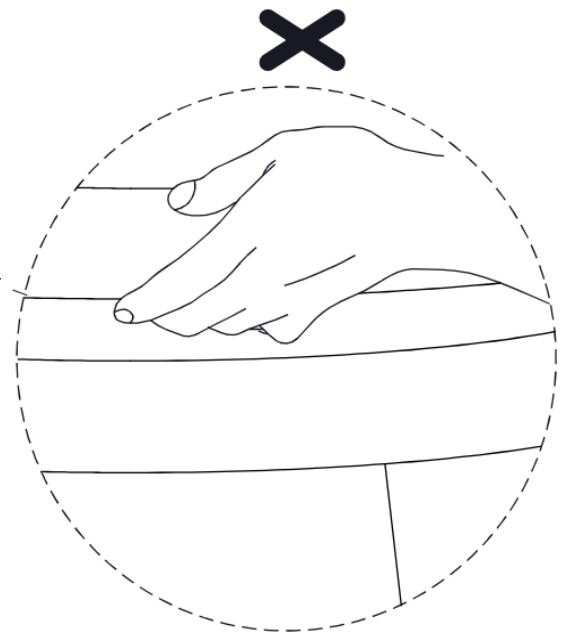
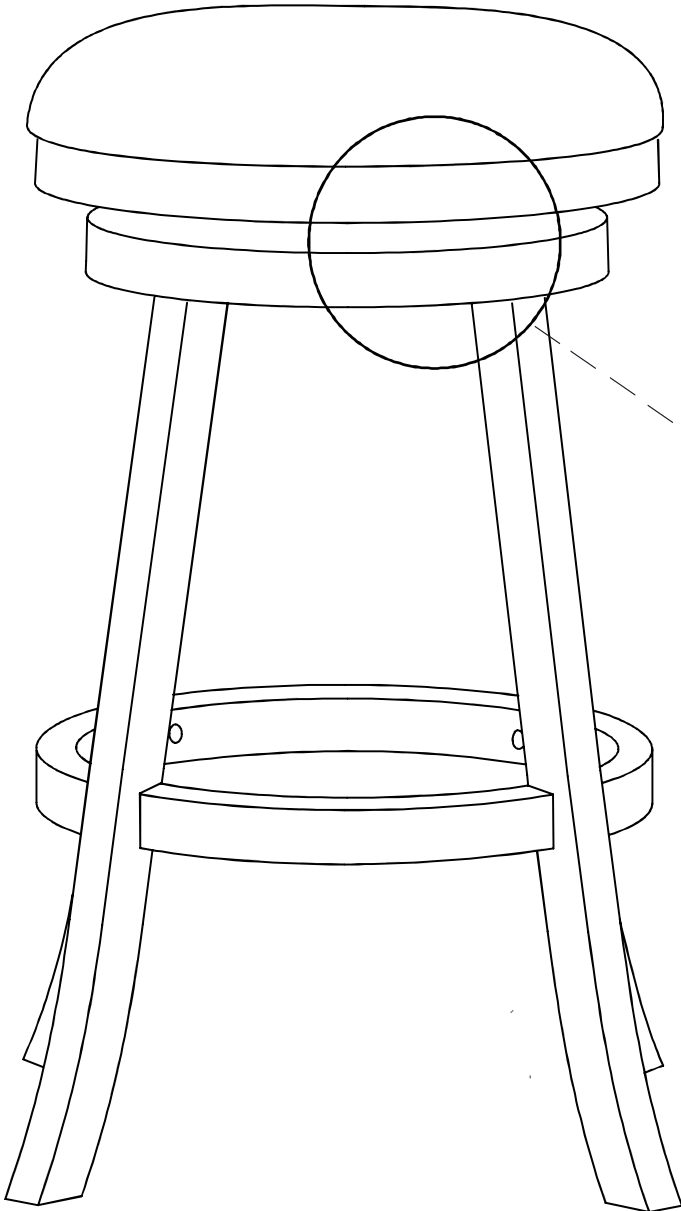

**BE SURE TO CHECK ALL BOLTS ARE SECURELY TIGHTENED PRIOR TO USE.**