



Boraam Industries

ASSEMBLY INSTRUCTIONS

SKU: 75025,75125,75225 | SONOMA BENCH

**Note: Maximum Capacity-2 person,
300lbs per seat.**

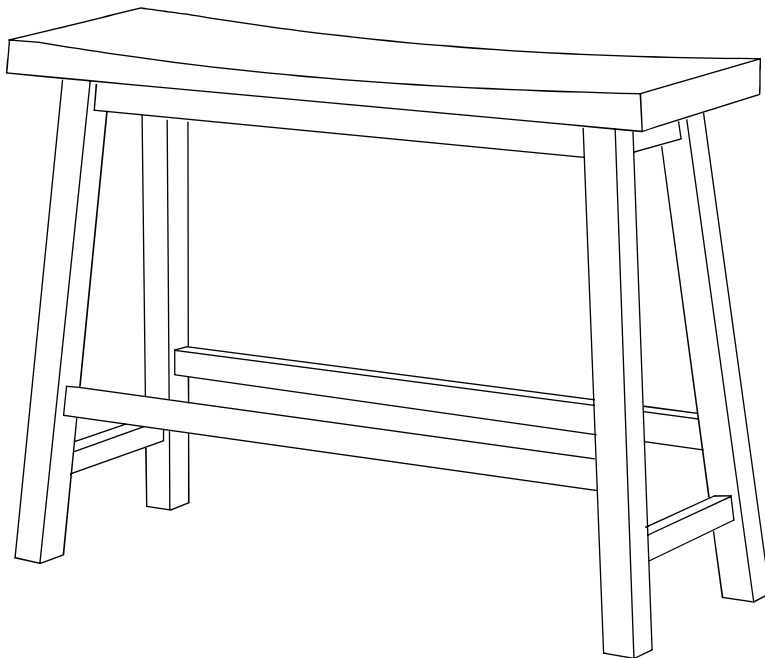

Locate the **HARDWARE PACK** which is attached to the shipping carton with red tape.

04/2024



Have questions about assembling your item?



Items or parts damaged?



Missing a part?

We're here to help! (Monday-Friday from 9am-5pm CST)



847-949-6300
877-267-2261



customerservice@
boraamindustries.com



www.boraamindustries.com

Assembly And Care

- All tools required for assembly are included unless noted.
- Prior to assembly, check for missing or damaged parts.
- Do not dispose of packing materials until assembly is completed.
- Assemble item on a soft, clean surface to prevent damage to the item.



Locate the **HARDWARE PACK** which is attached to the shipping carton with red tape.

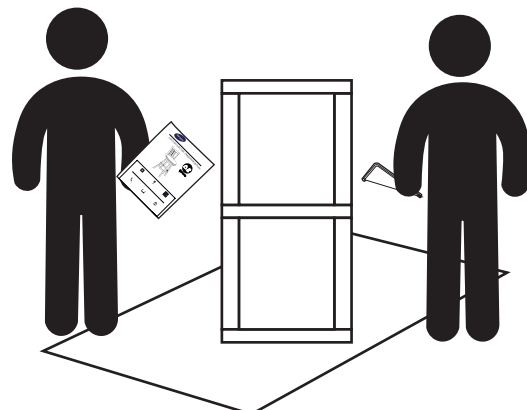
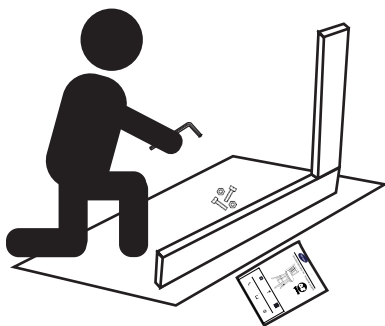
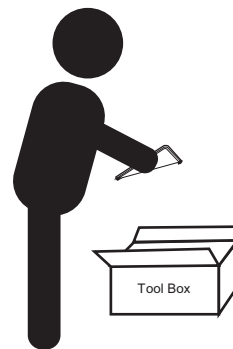
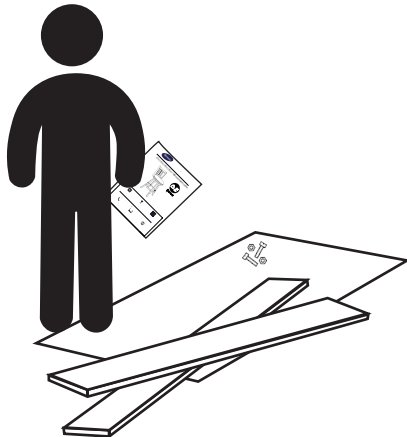

Assembly Overview

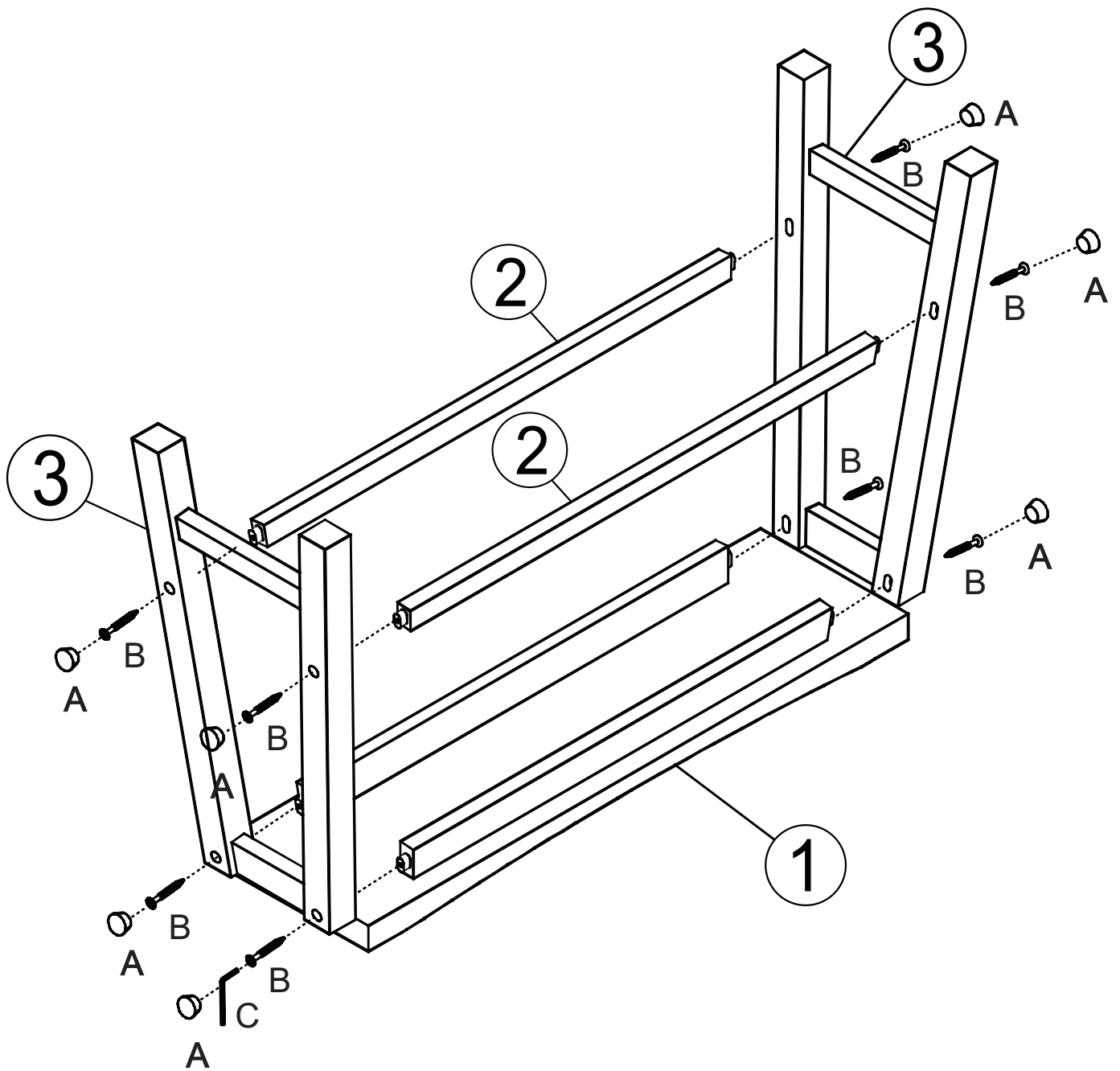

PARTS

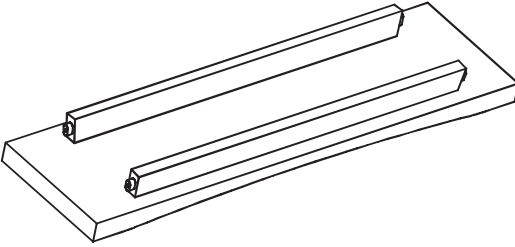
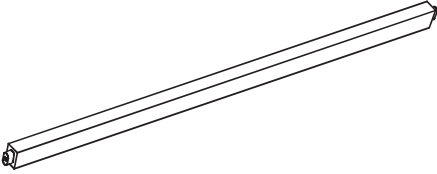
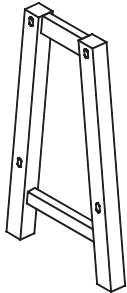
① (x1)	
Seat : 	
② (x2)	③ (x2)
Side Stretcher : 	Frame Leg : 

HARDWARE

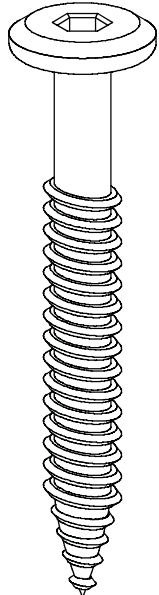
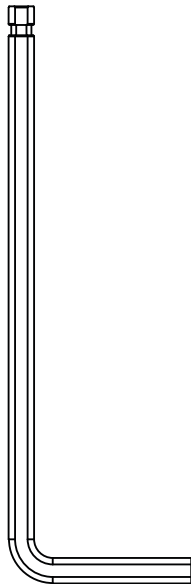
Ⓐ (x8)	Ⓑ (x8)	Ⓒ (x1)
		
Wood Nut	M6x50	Allen Wrench

01

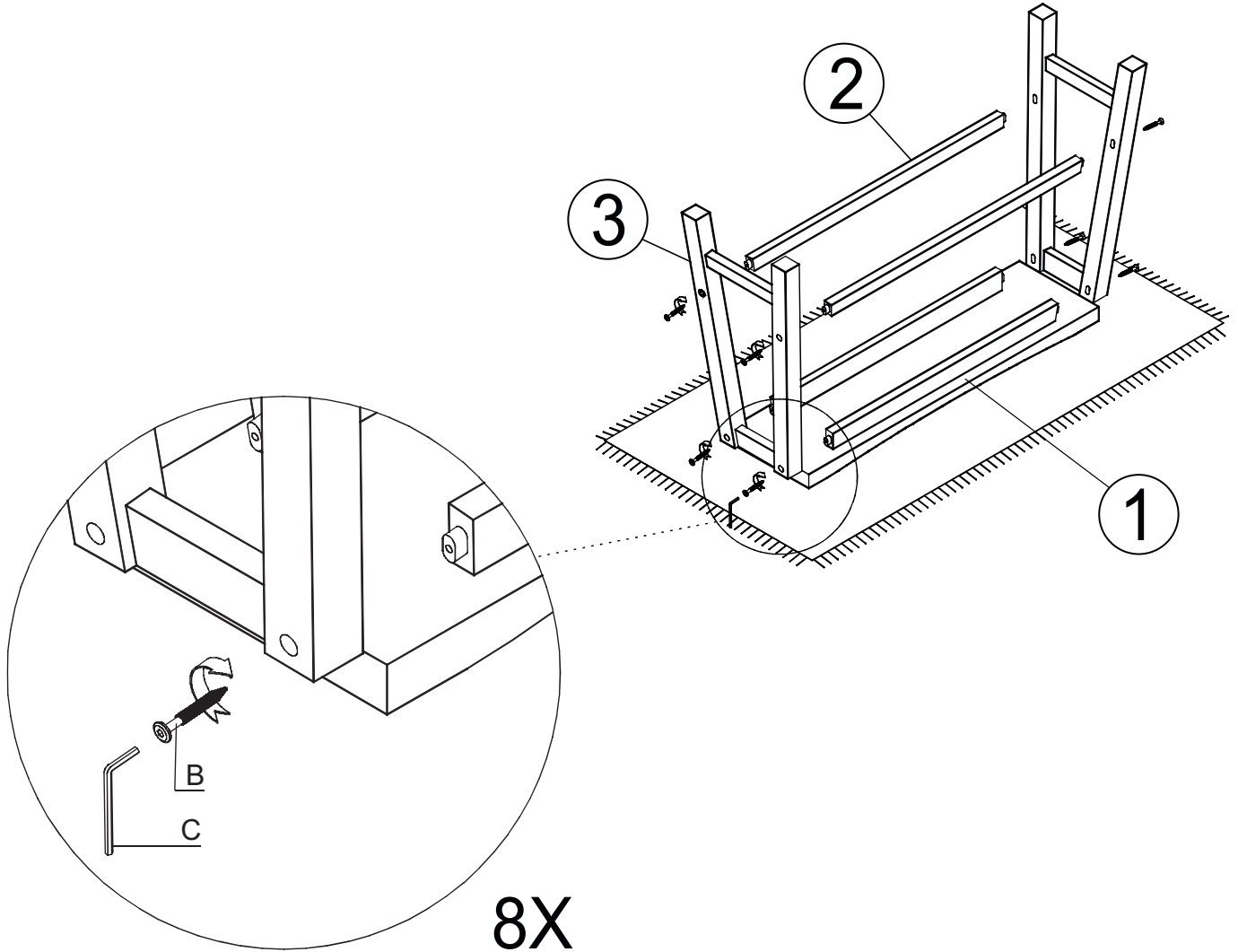

Hardware	Count
B	8
C	1

TIGHTEN BOLT COMPLETELY.

02

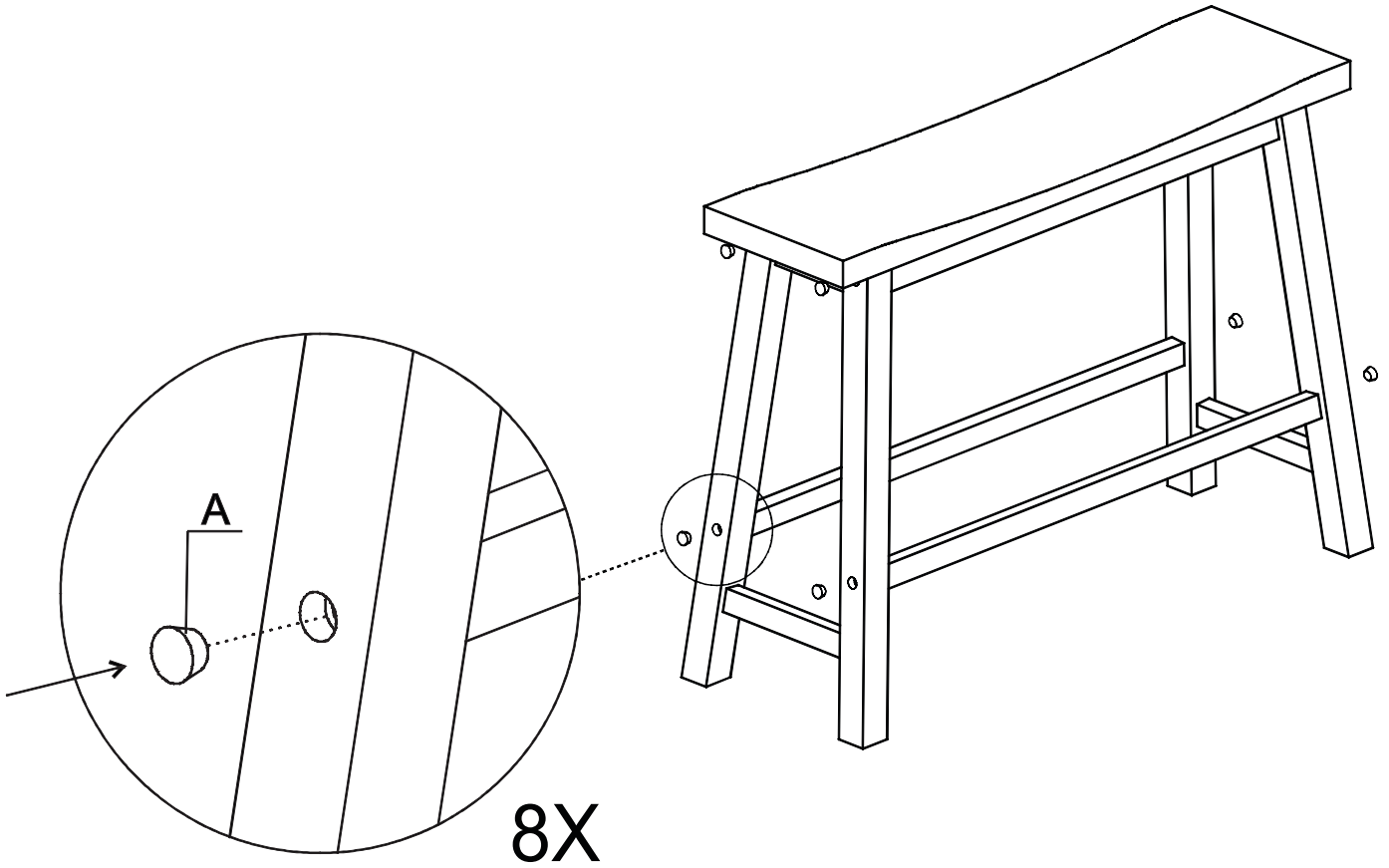

Hardware	Count
A	8

TIGHTEN BOLT COMPLETELY.

**Note: Maximum Capacity-2 person,
300lbs per seat.**

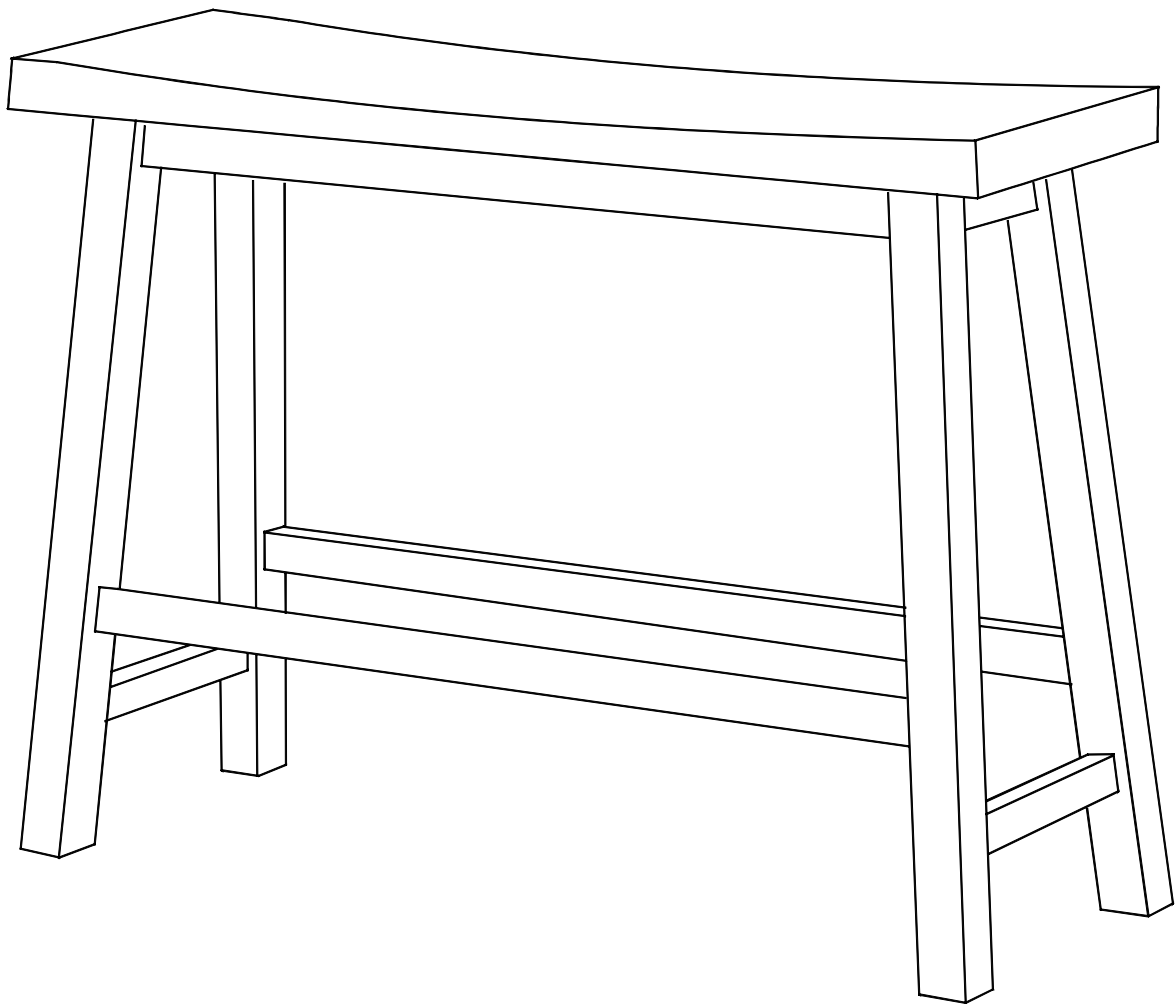

BE SURE TO CHECK ALL BOLTS ARE SECURELY TIGHTENED PRIOR TO USE.

847-949-6300 | 877-267-2261 | customerservice@boraamindustries.com