

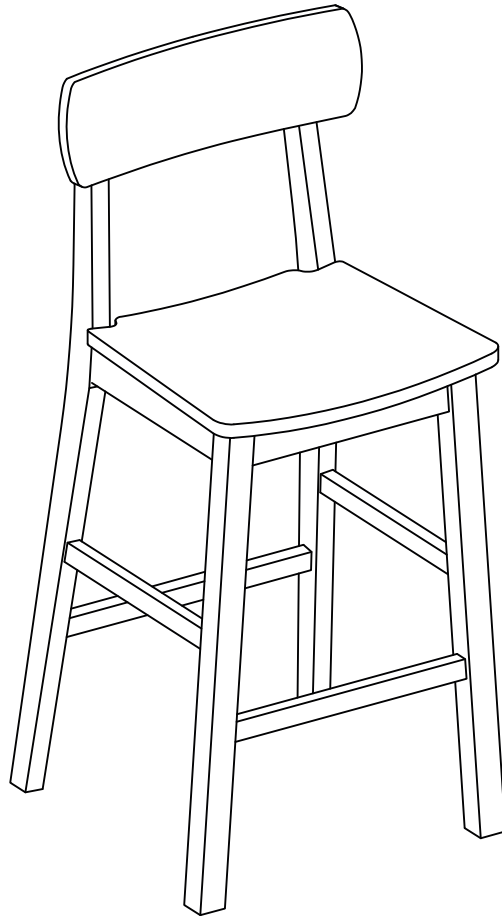

Boraam Industries

ASSEMBLY INSTRUCTIONS

SKU: 76724,76729,86724 | TORINO STOOL



Weight Capacity



Locate the **HARDWARE PACK** which is attached to the shipping carton with red tape.

06/2025



Have questions about assembling your item?



Items or parts damaged?



Missing a part?

We're here to help! (Monday-Friday from 9am-5pm CST)



847-949-6300
877-267-2261



customerservice@
boraamindustries.com



www.boraamindustries.com



Philips screwdriver
not included.

Assembly And Care

- All tools required for assembly are included unless noted.
- Prior to assembly, check for missing or damaged parts.
- Do not dispose of packing materials until assembly is completed.
- Assemble item on a soft, clean surface to prevent damage to the item.



Locate the
HARDWARE PACK
which is attached to the
shipping carton with red
tape.

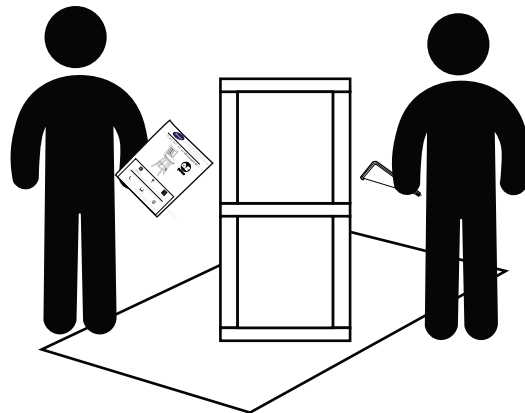
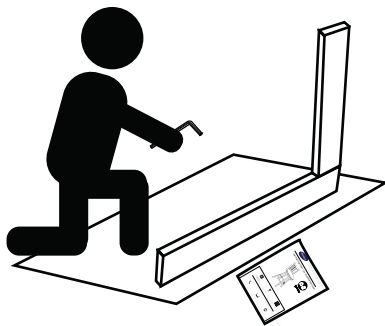
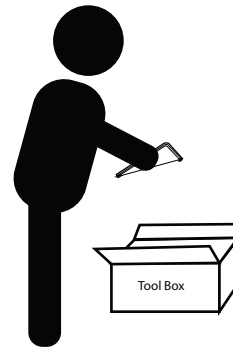
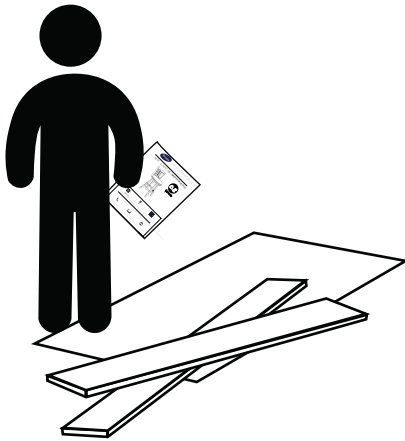

Assembly Overview

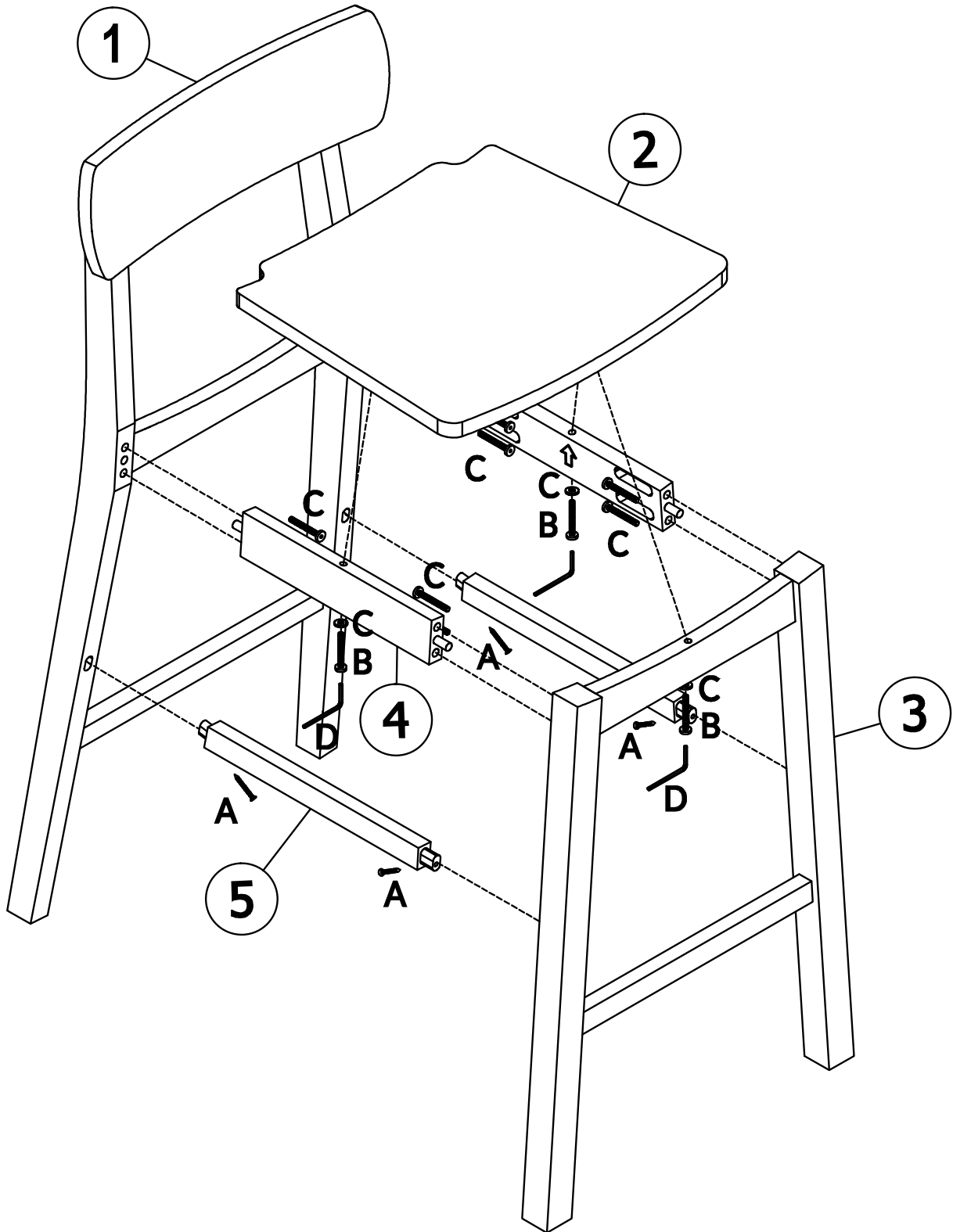

PARTS

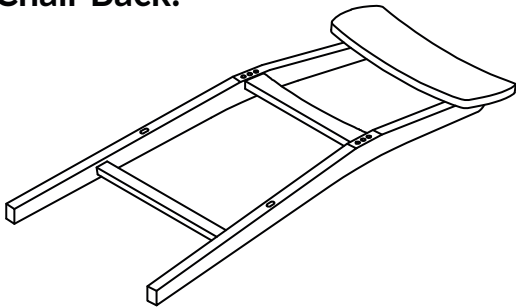
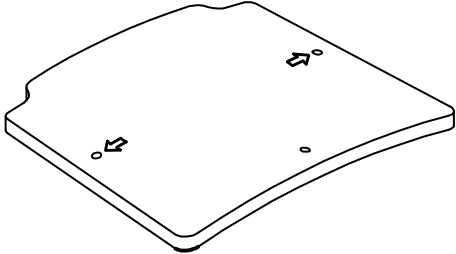
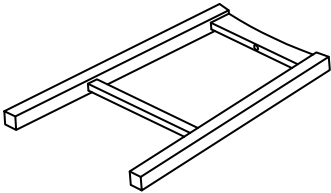
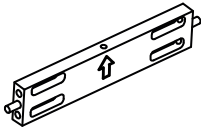
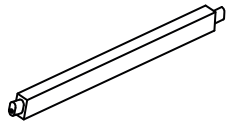
① (x1)		② (x1)	
Chair Back: 		Seat Frame: 	
③ (x1)	④ (x2)		⑤ (x2)
Leg Frame: 	Side Apron: 		Side Stretcher: 

HARDWARE

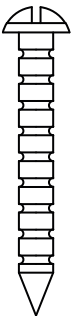
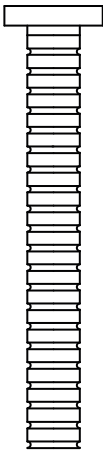
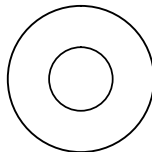
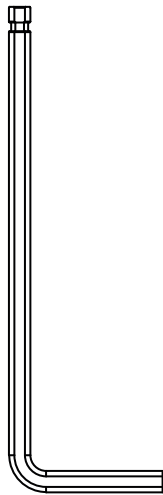
Ⓐ (x4)	Ⓑ (x11)	Ⓒ (x3)	Ⓓ (x1)
			
Screw M4x35	Bolt M6x50	Flat Washer	Allen Wrench

01

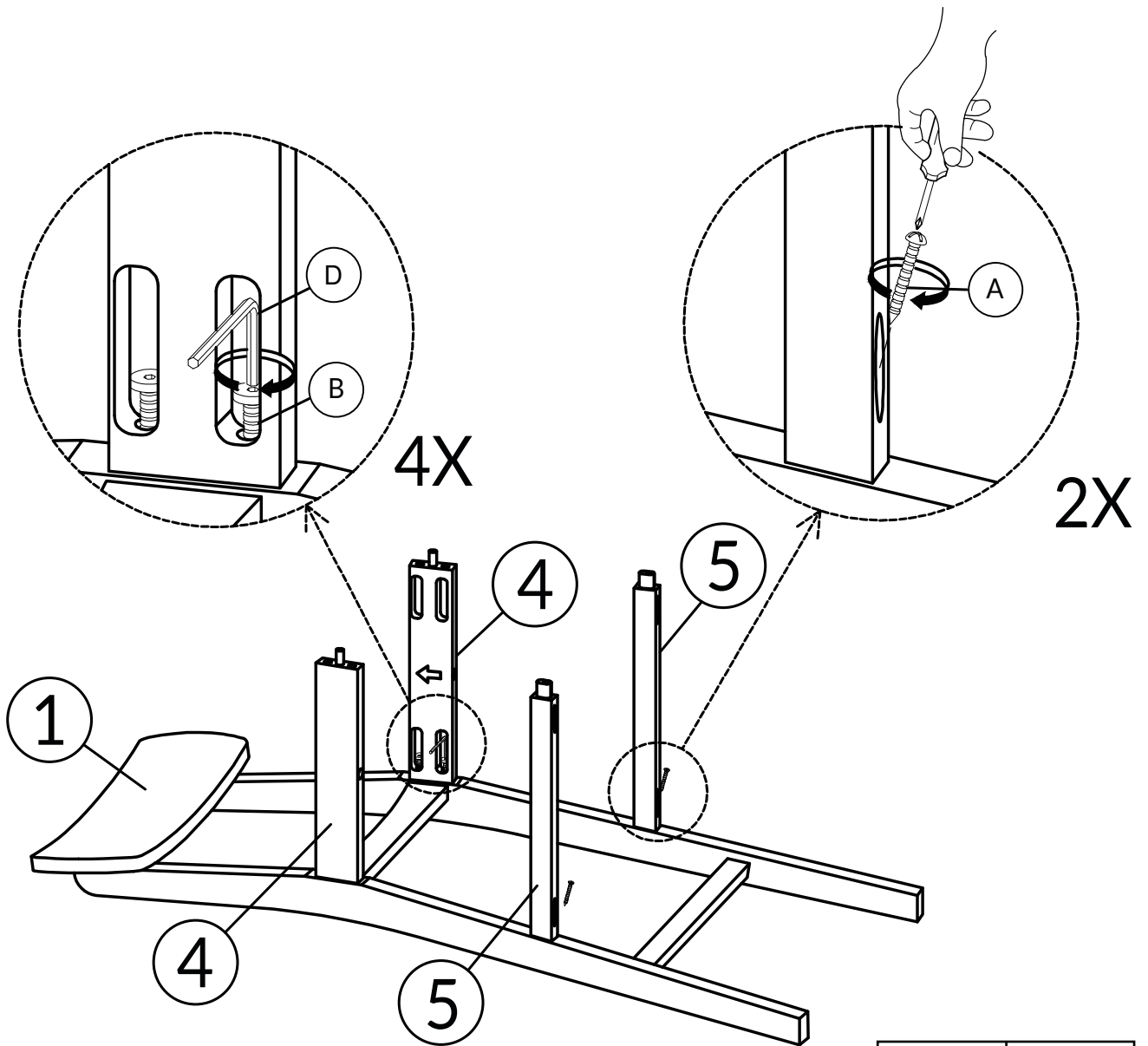

Hardware	Count
A	2
B	4
D	1

Attach part 4 by following the arrow direction shown in the picture above to ensure correct alignment.

DO NOT TIGHTEN BOLT AND SCREW COMPLETELY.

02

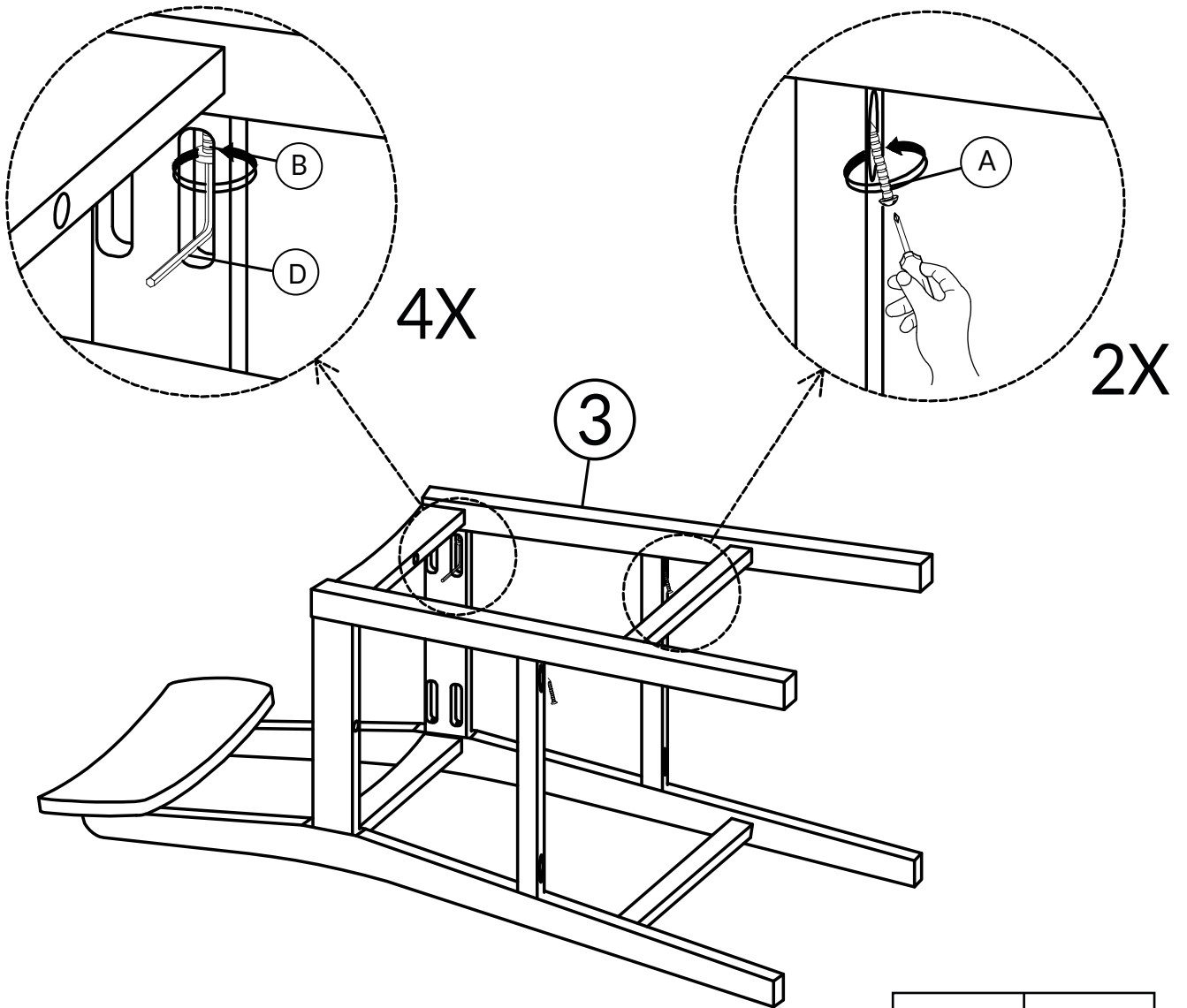

Hardware	Count
A	2
B	4
D	1

DO NOT TIGHTEN BOLT AND SCREW COMPLETELY.

03

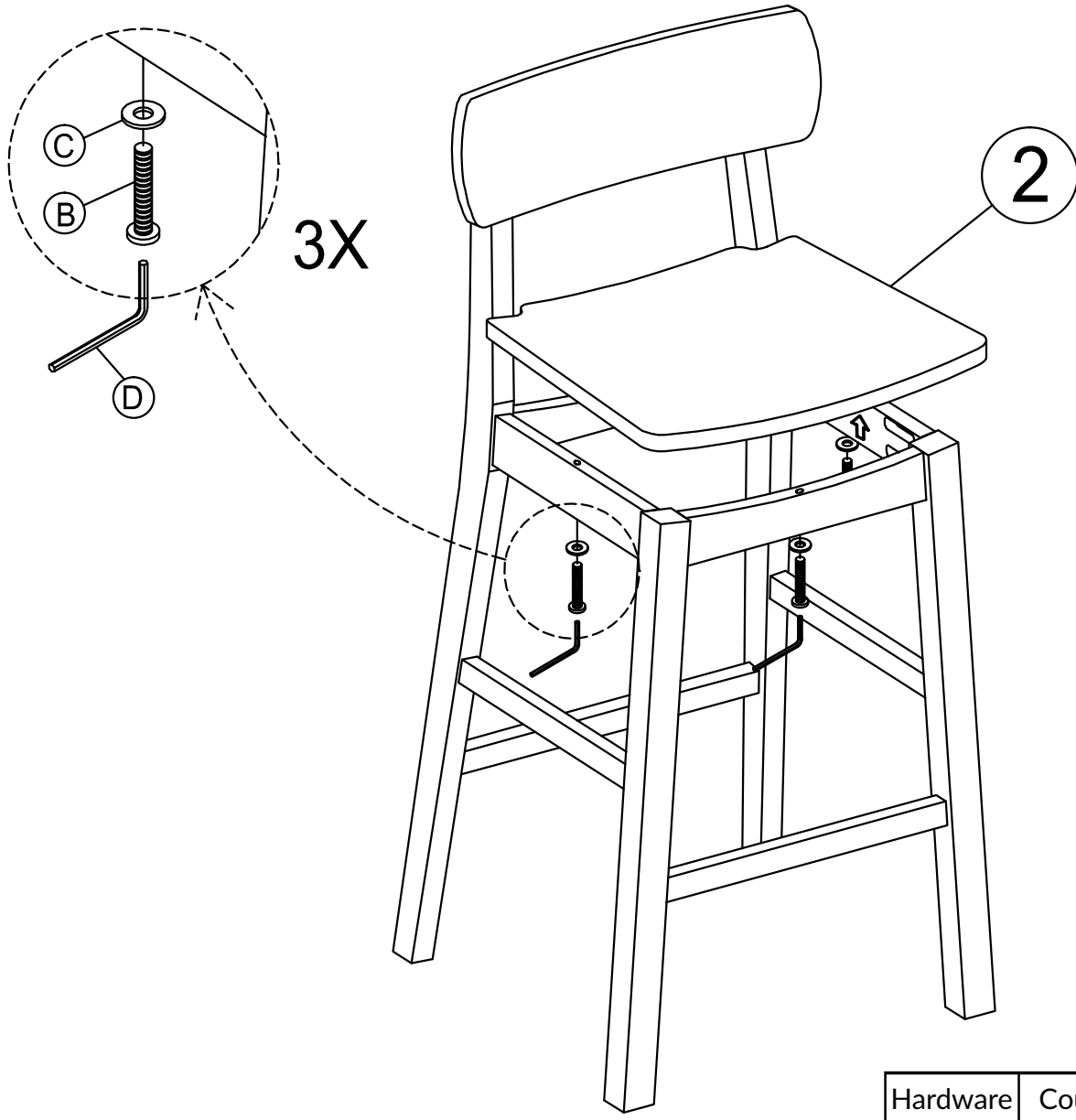

TIGHTEN BOLT AND SCREW COMPLETELY.

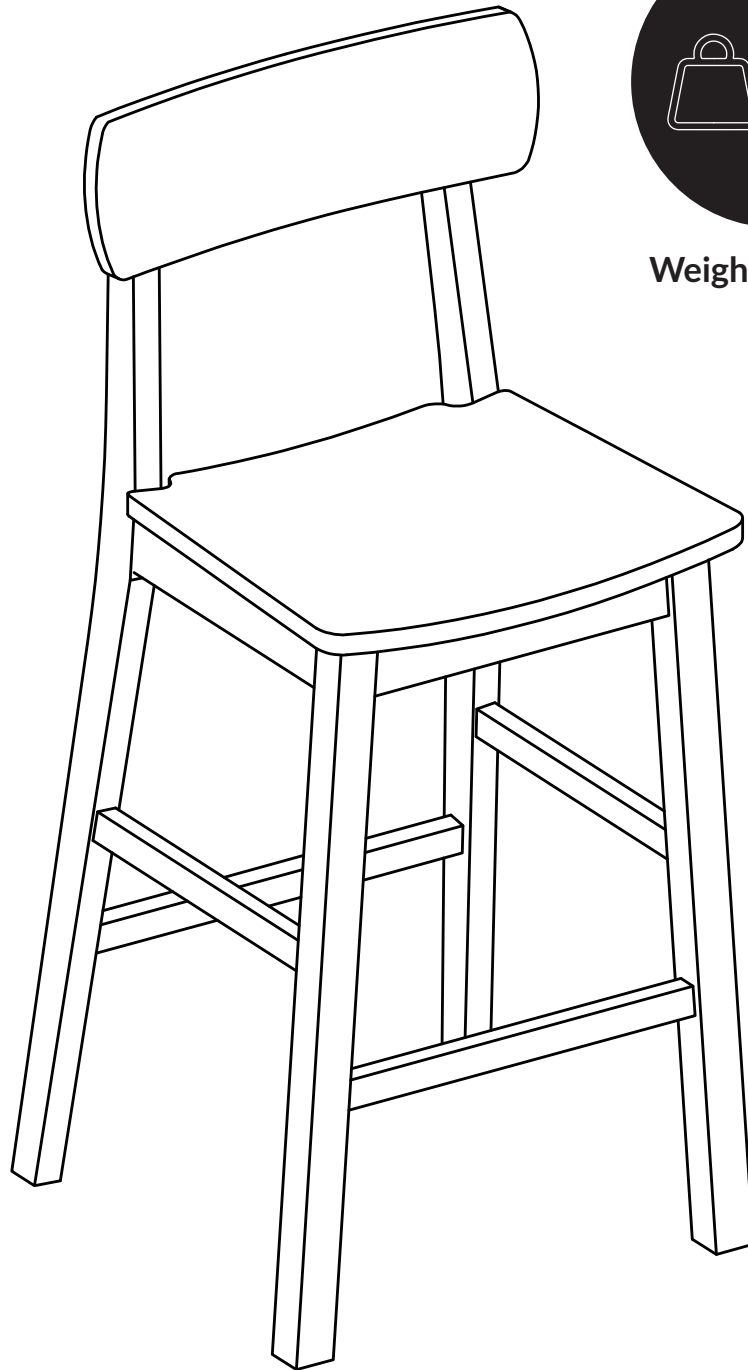

Weight Capacity

BE SURE TO CHECK ALL BOLTS ARE SECURELY TIGHTENED PRIOR TO USE.

847-949-6300 | 877-267-2261 | customerservice@boraamindustries.com