



Boraam Industries

ASSEMBLY INSTRUCTIONS

SKU: 98521

SONOMA KITCHEN CART - CHESTNUT WIRE - BRUSH

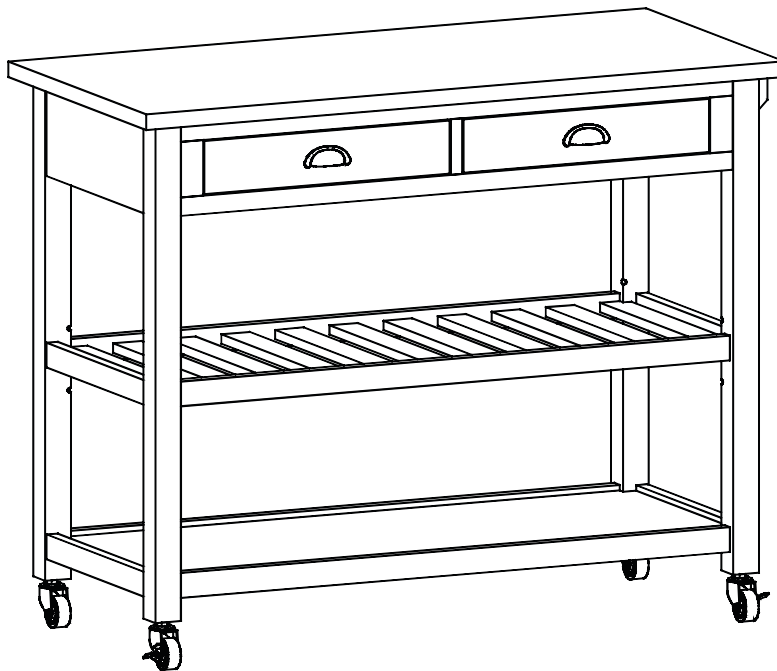

Weight Capacity



Locate the **HARDWARE PACK** which is attached to the shipping carton with red tape.

1/2024



Have questions about assembling your item?



Items or parts damaged?



Missing a part?

We're here to help! (Monday-Friday from 9am-5pm CST)



847-949-6300
877-267-2261



customerservice@
boraamindustries.com



www.boraamindustries.com

Assembly And Care

- All tools required for assembly are included unless noted.
- Prior to assembly, check for missing or damaged parts.
- Do not dispose of packing materials until assembly is completed.
- Assemble item on a soft, clean surface to prevent damage to the item.
- Periodically check hardware and re-tighten as necessary.



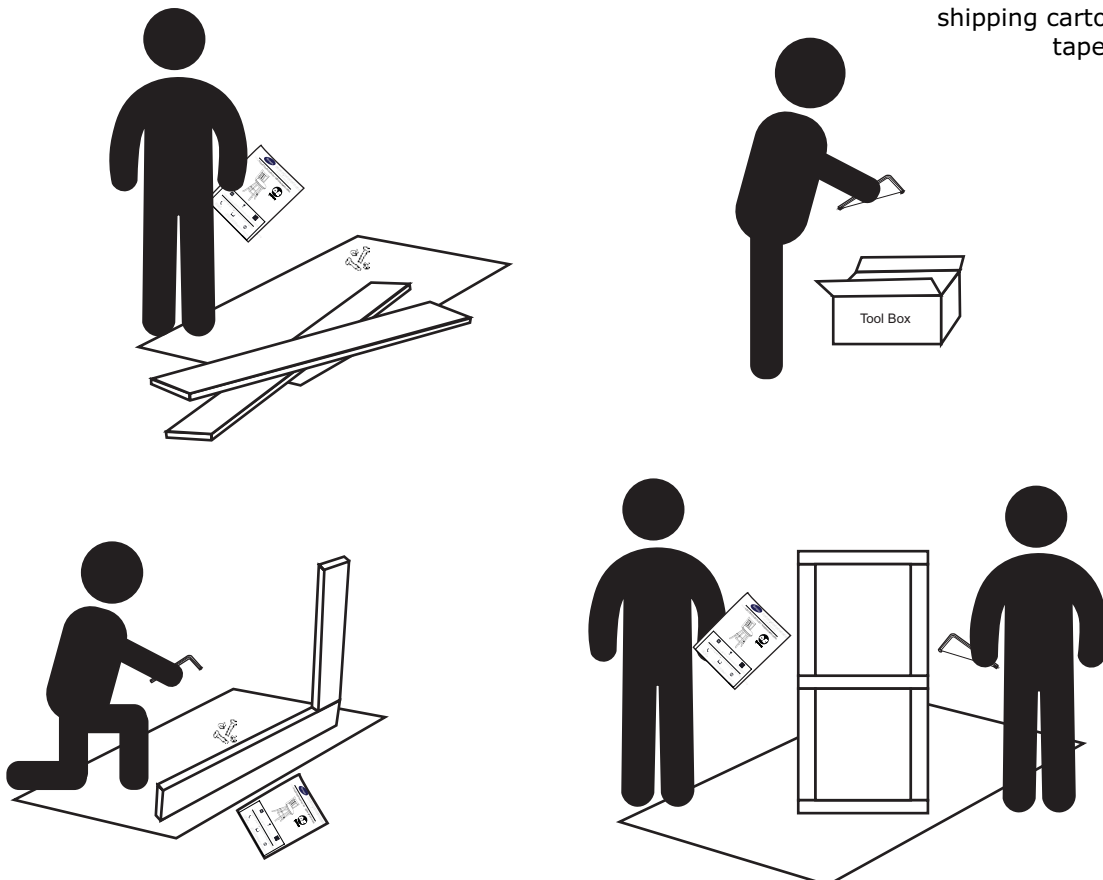

Locate the **HARDWARE PACK** which is attached to the shipping carton with red tape.



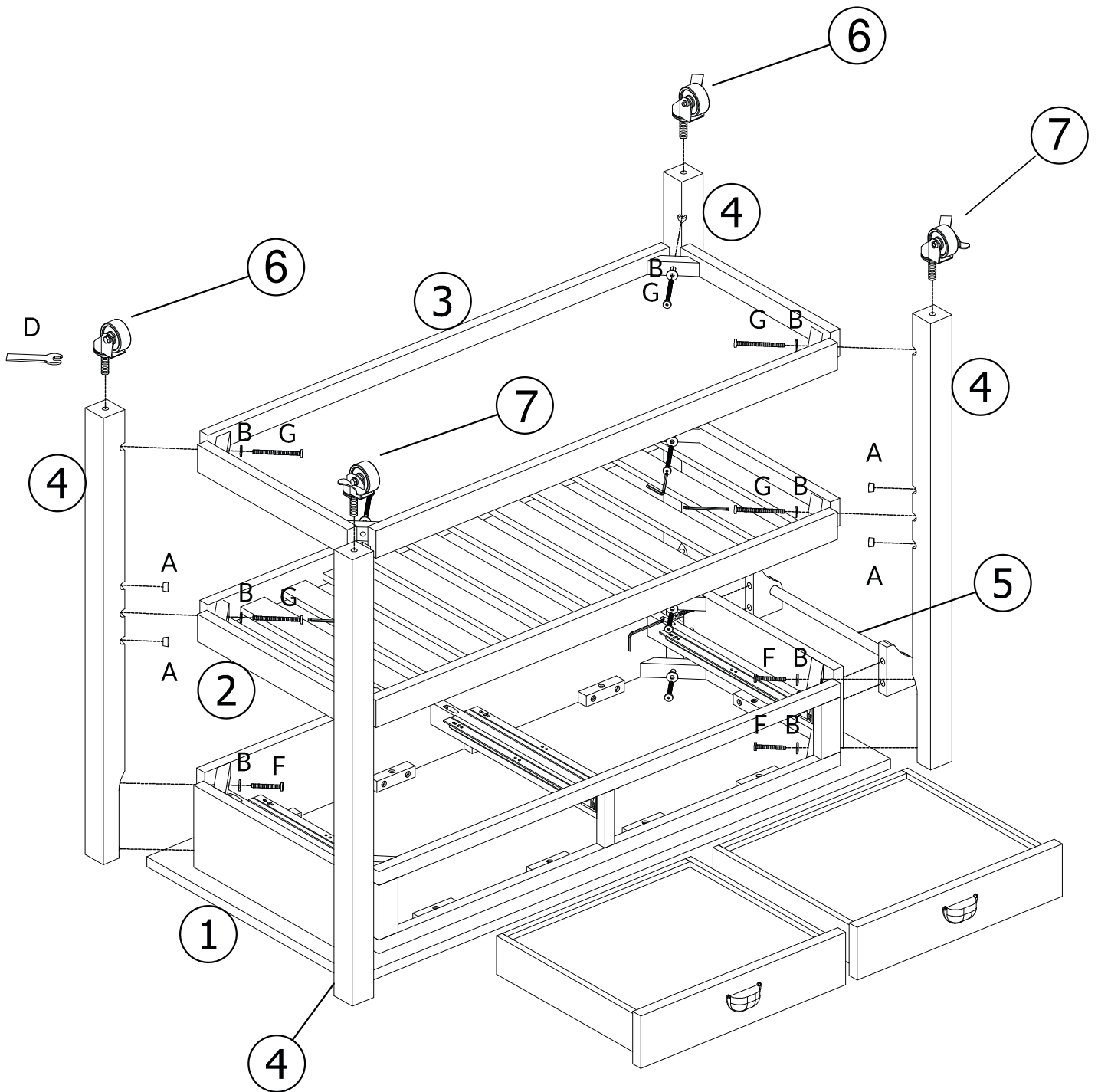

Assembly Overview

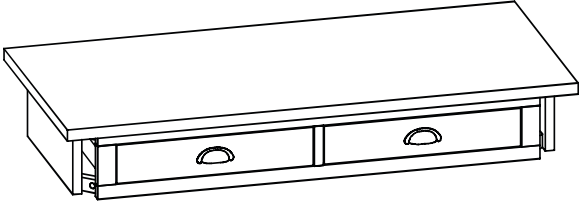
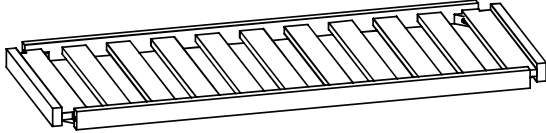

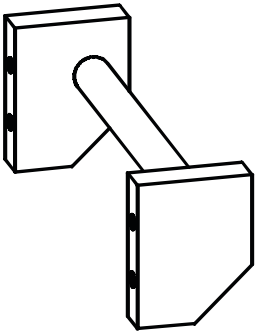
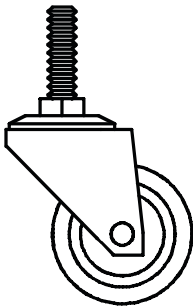
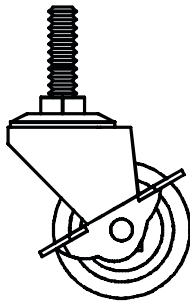
PARTS

<p>① (x1)</p>	<p>② (x1)</p>	
<p>Top with Drawers:</p>  A perspective drawing of a rectangular top panel with two drawers on the front side, each with a semi-circular handle.	<p>Middle shelf:</p>  A perspective drawing of a slatted shelf with multiple parallel wooden slats supported by a frame.	
<p>③ (x1)</p>	<p>④ (x4)</p>	
<p>Bottom shelf:</p>  A perspective drawing of a simple rectangular shelf with a slightly raised edge on one side.	<p>Leg:</p>  A vertical rectangular leg with four small circular holes spaced evenly along its length.	
<p>⑤ (x1)</p>	<p>⑥ (x2)</p>	<p>⑦ (x2)</p>
<p>Rack:</p>  A perspective drawing of a metal rack consisting of two rectangular plates connected by a central cylindrical rod.	<p>Caster:</p>  A perspective drawing of a standard swivel caster with a threaded stem and a single wheel.	<p>Caster with lock:</p>  A perspective drawing of a swivel caster with a threaded stem, a wheel, and a locking mechanism consisting of a small metal bar across the wheel.

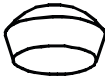
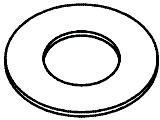
HARDWARE

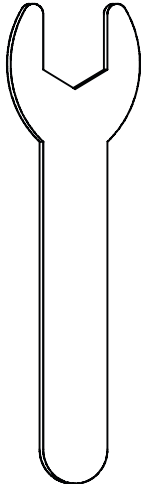
Ⓐ (x8)	Ⓑ (x16)	Ⓒ (x1)	Ⓓ (x1)
			
Wood Nut	Flat Washer	Allen Wrench	Wrench

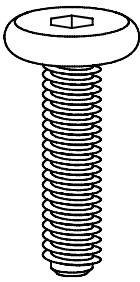
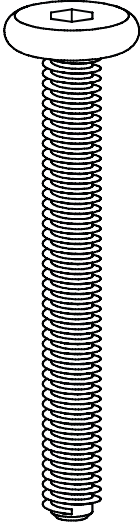
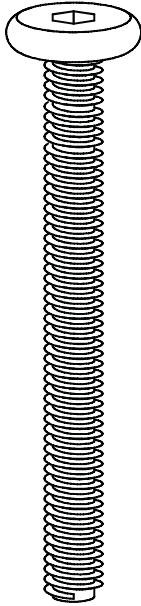
Ⓔ (x4)	Ⓕ (x8)	Ⓖ (x8)
		
Bolt M6x35	Bolt M6x50	Bolt M6x70

01

2X

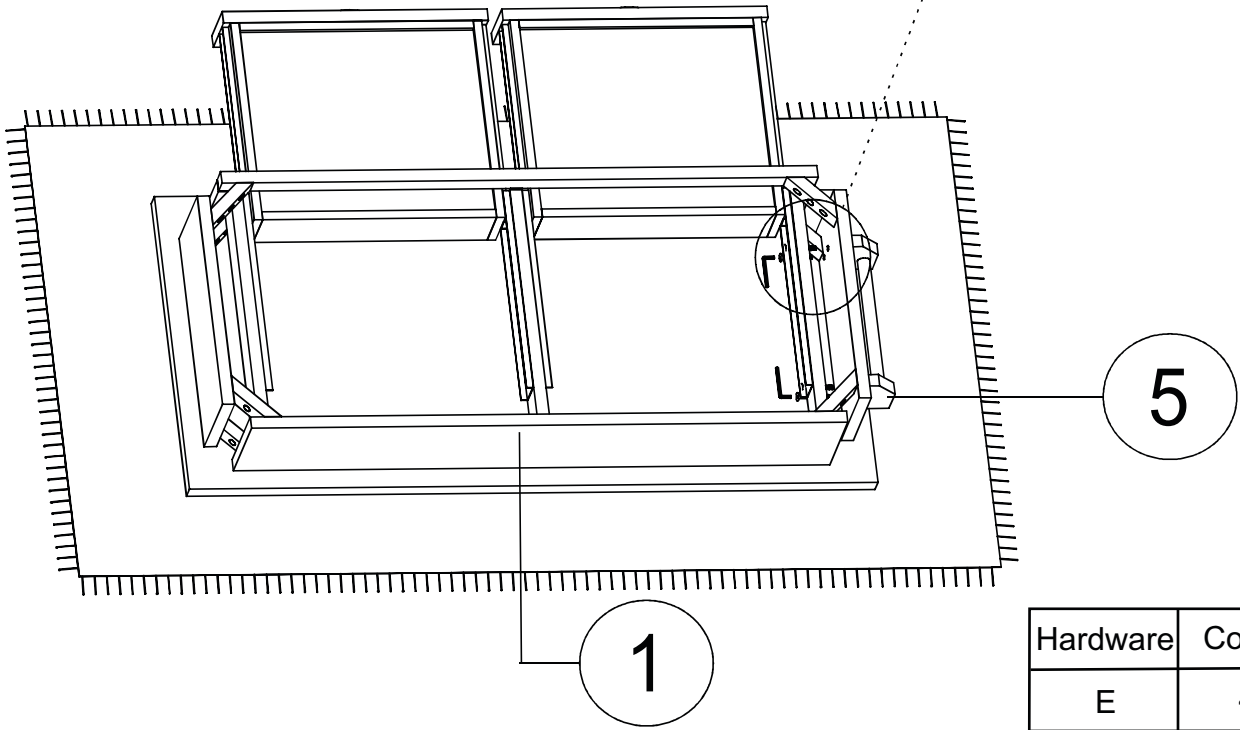
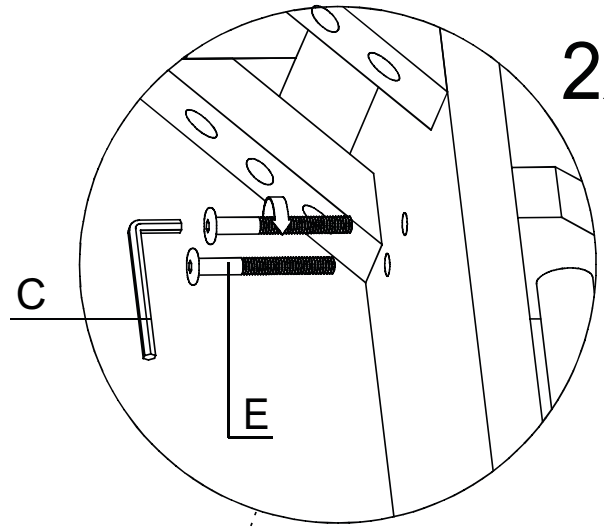

Hardware	Count
E	4
C	1

TIGHTEN BOLT COMPLETELY.

02

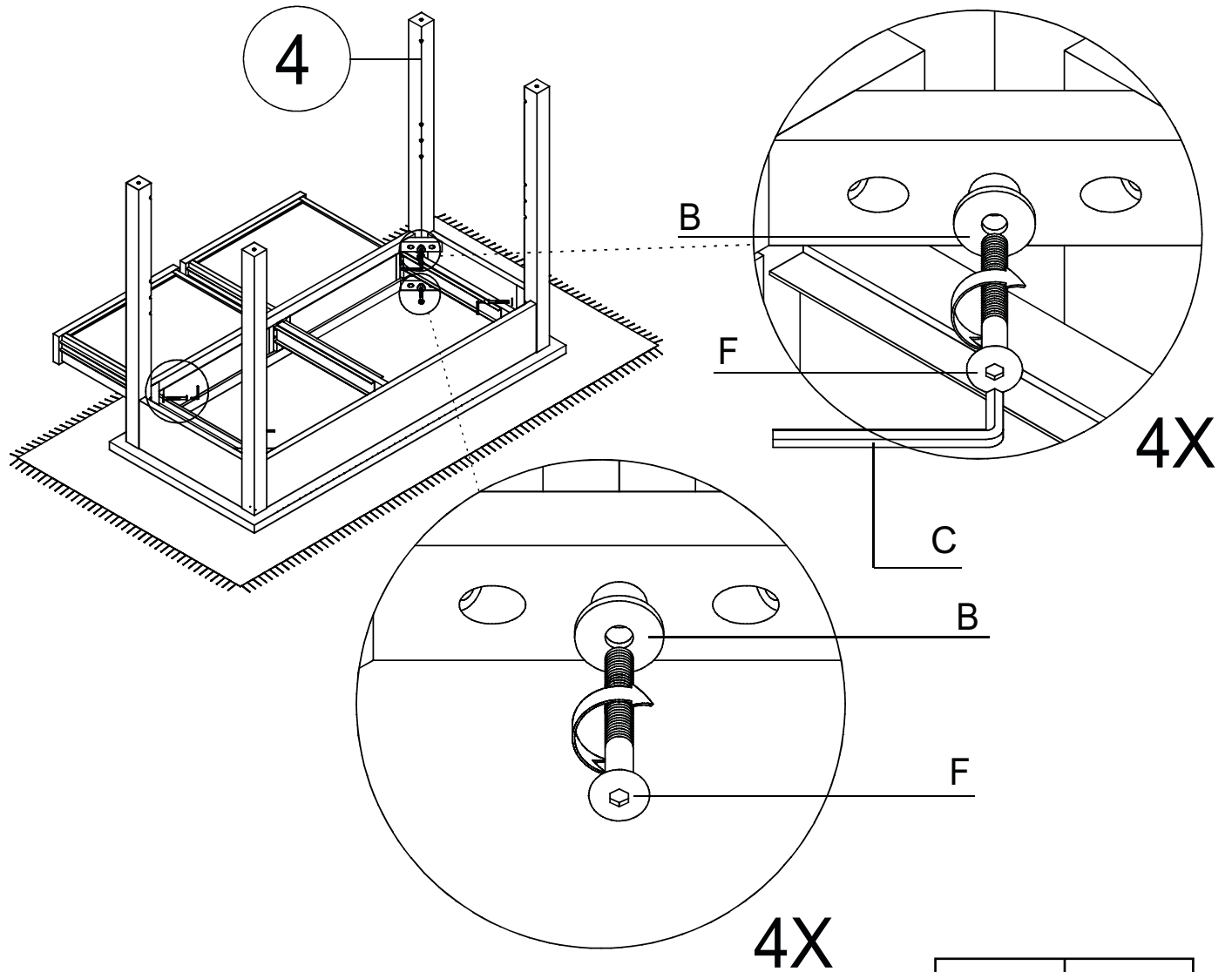

Hardware	Count
B	8
F	8
C	1

DO NOT TIGHTEN BOLT COMPLETELY.

03

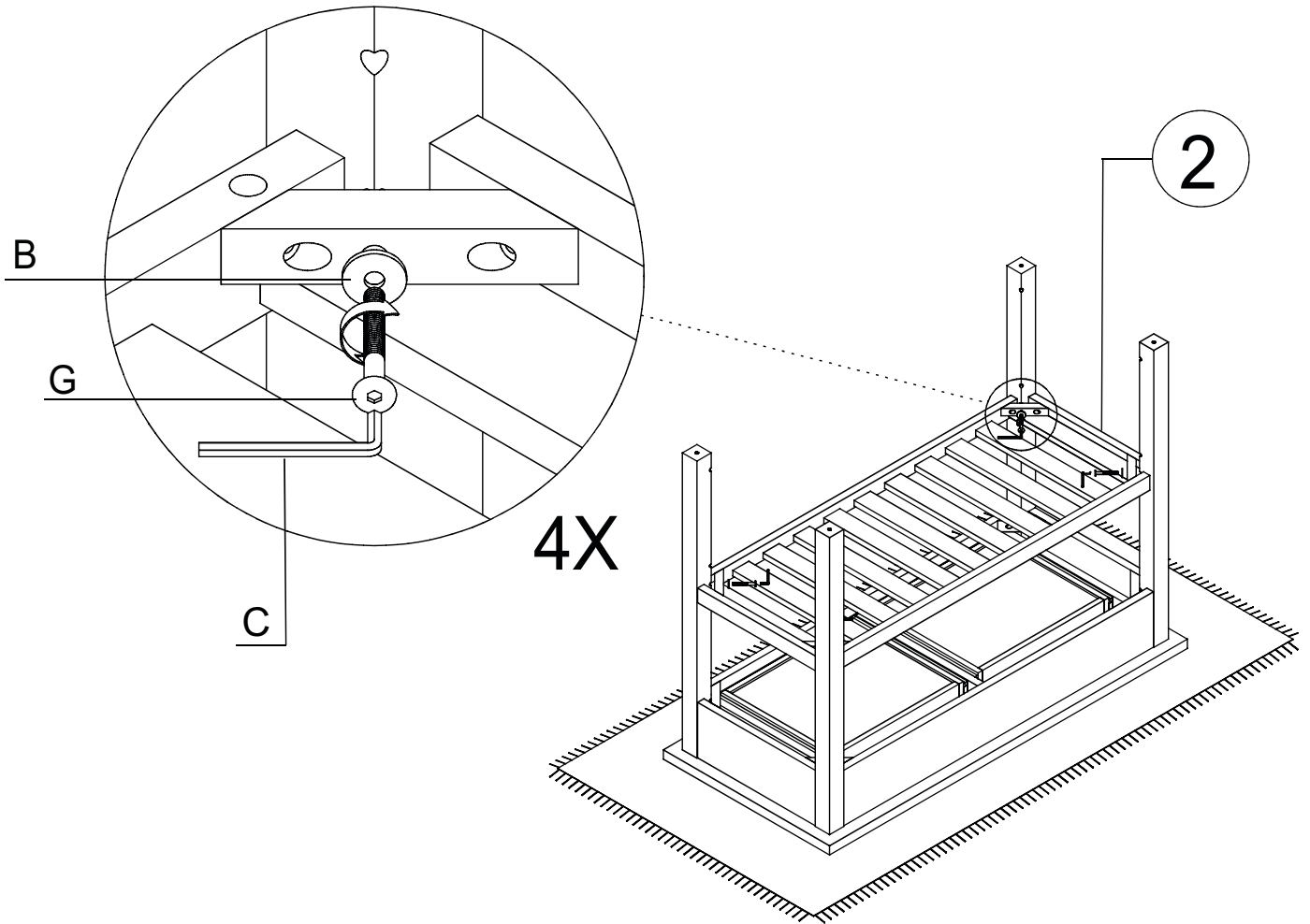

4X

Hardware	Count
B	4
G	4
C	1

TIGHTEN BOLT COMPLETELY.

04

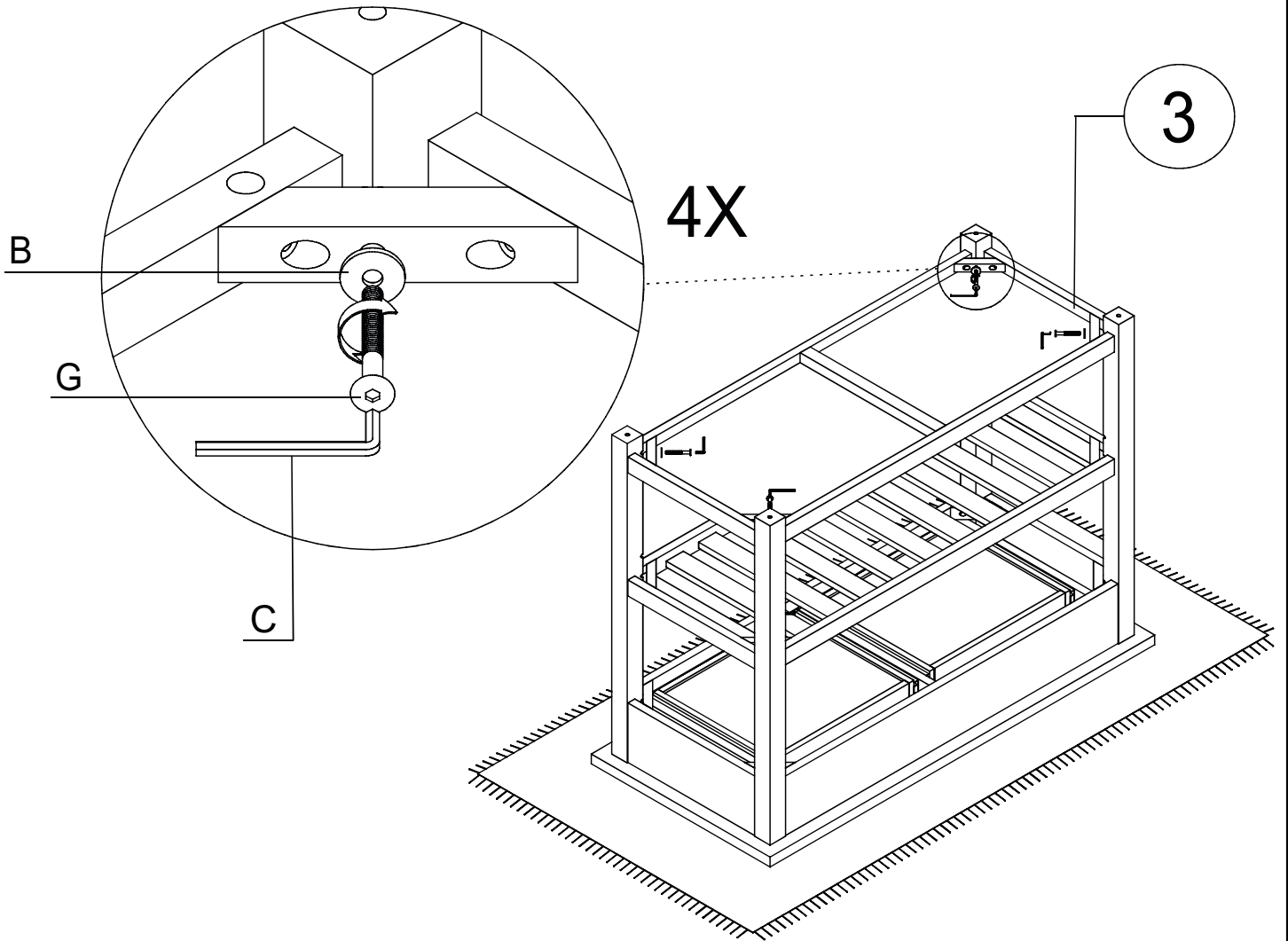

Hardware	Count
B	4
G	4
C	1

TIGHTEN BOLT COMPLETELY.

05

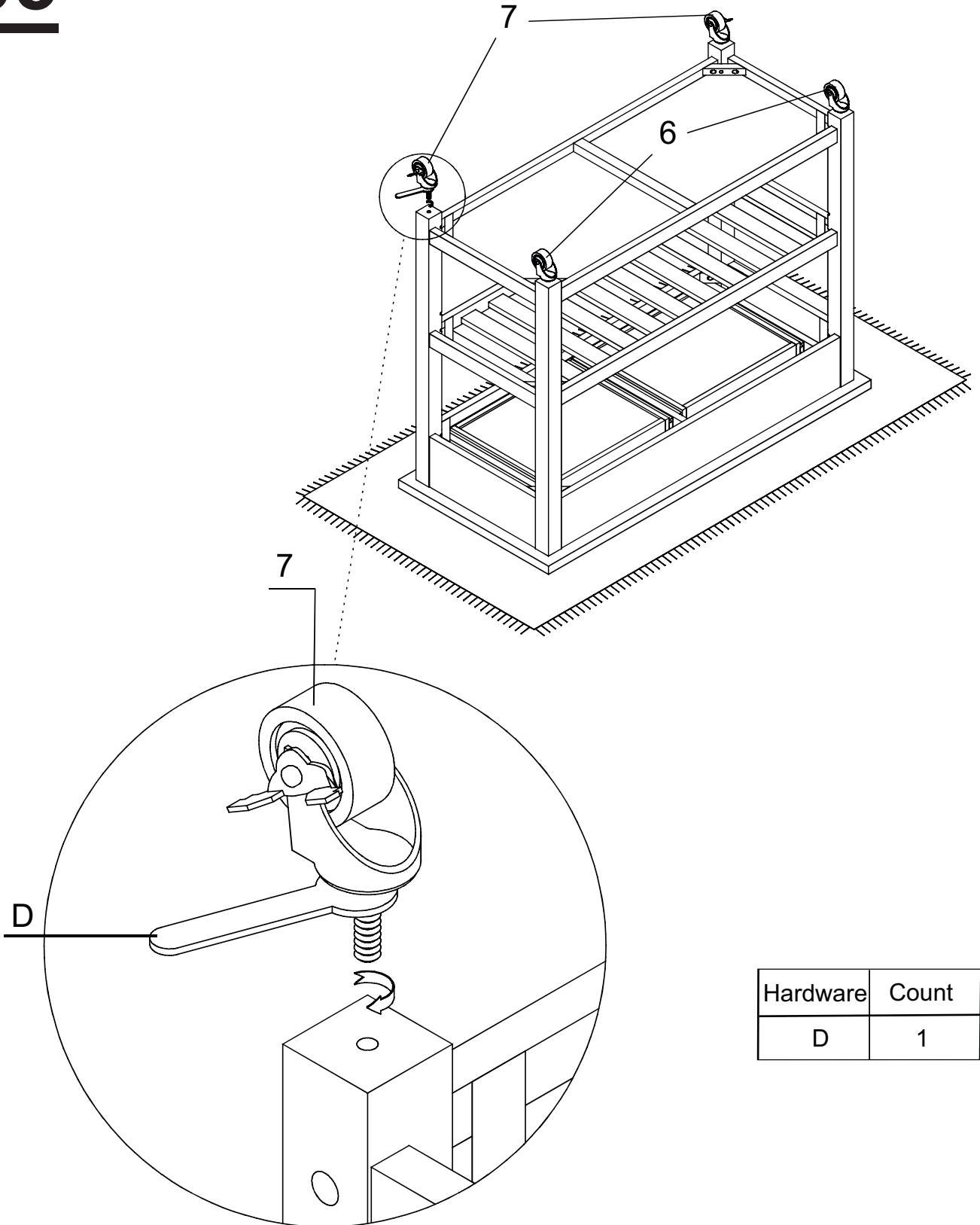

Hardware	Count
D	1

TIGHTEN BOLT COMPLETELY.

06

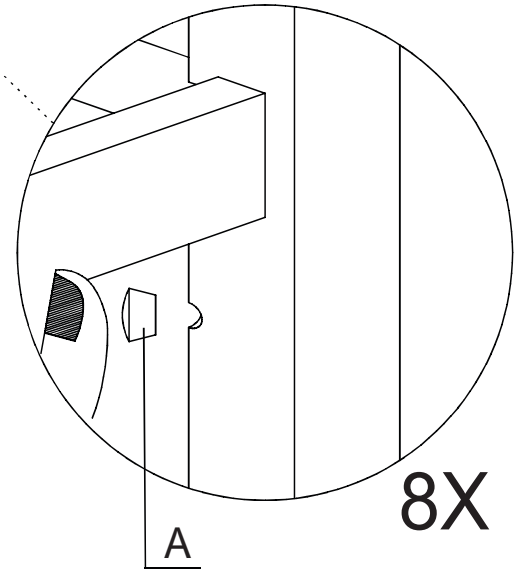
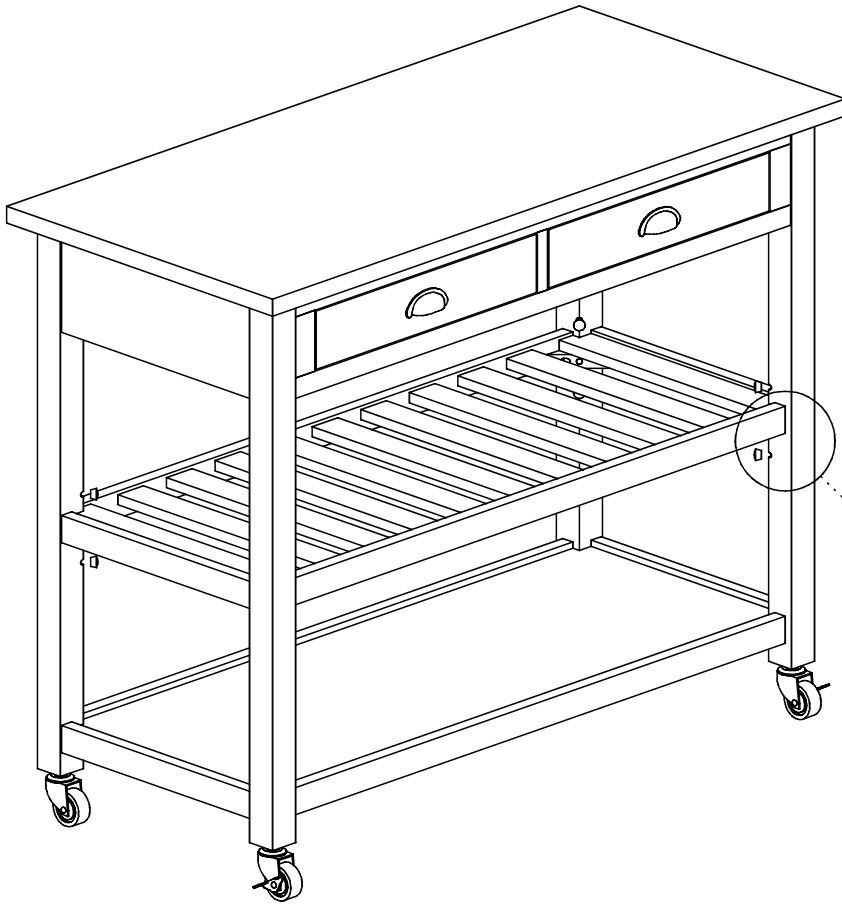

Hardware	Count
A	8



Weight Capacity

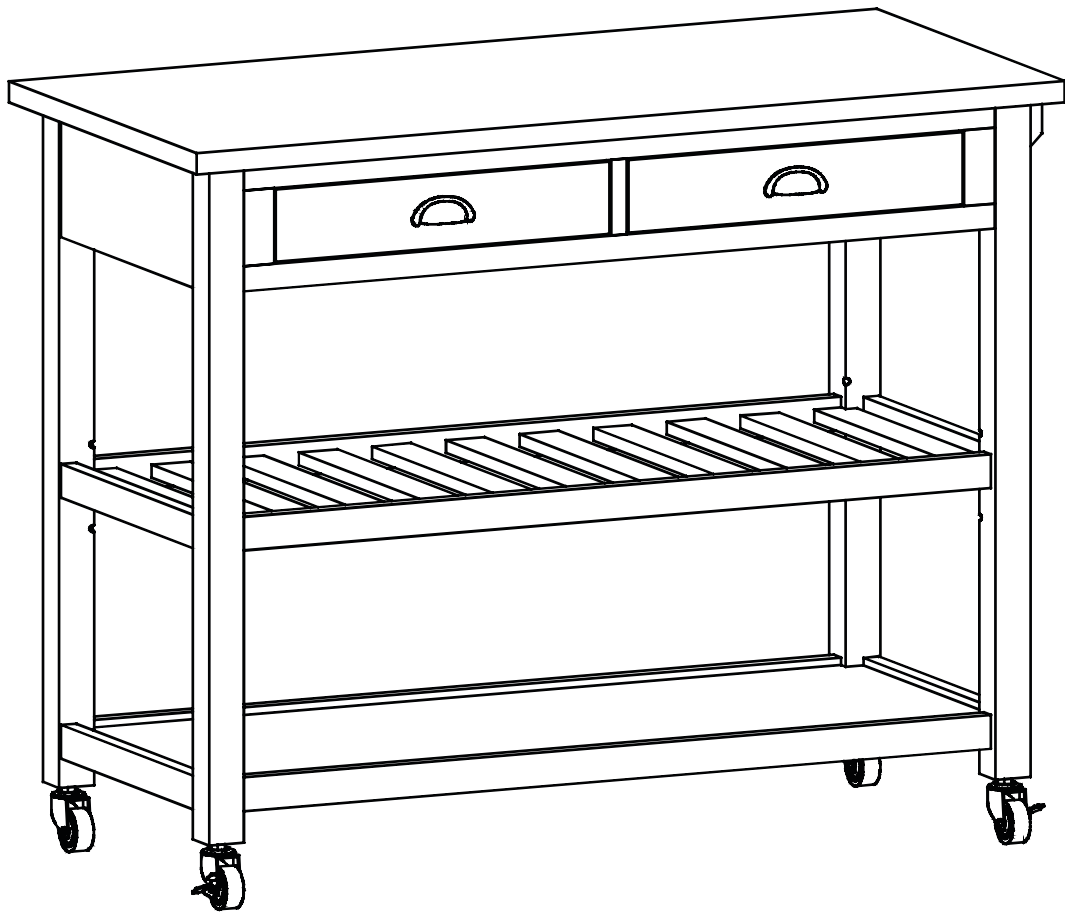

BE SURE TO CHECK ALL BOLTS ARE SECURELY TIGHTENED PRIOR TO USE.

847-949-6300 | 877-267-2261 | customerservice@boraamindustries.com