



# Boraam Industries

ASSEMBLY INSTRUCTIONS

SKU:46134

PALMETTO SWIVEL EXTRA TALL BARSTOOL



# UPDATED ASSEMBLY INSTRUCTIONS

DISREGARD OTHER INSTRUCTIONS

03/2026



Have questions about assembling your item?



Items or parts damaged?



Missing a part?

**We're here to help! (Monday-Friday from 9am-5pm CST)**



847-949-6300  
877-267-2261



customerservice@  
boraamindustries.com



www.boraamindustries.com

# Assembly And Care

- All tools required for assembly are included unless noted.
- Prior to assembly, check for missing or damaged parts.
- Do not dispose of packing materials until assembly is completed.
- Assemble item on a soft, clean surface to prevent damage to the item.



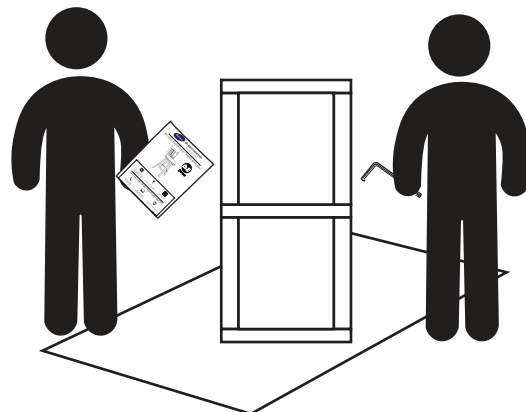
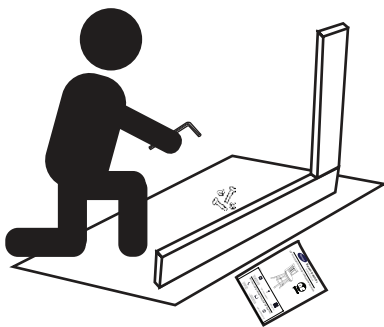
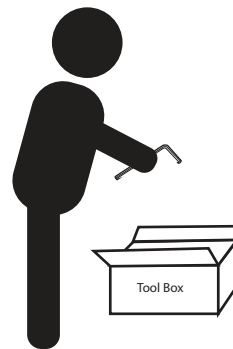
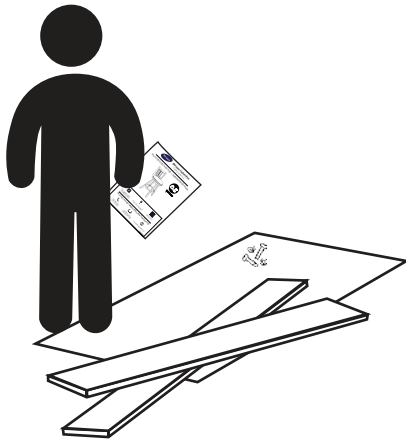

Locate the **HARDWARE PACK** which is attached to the shipping carton with red tape.



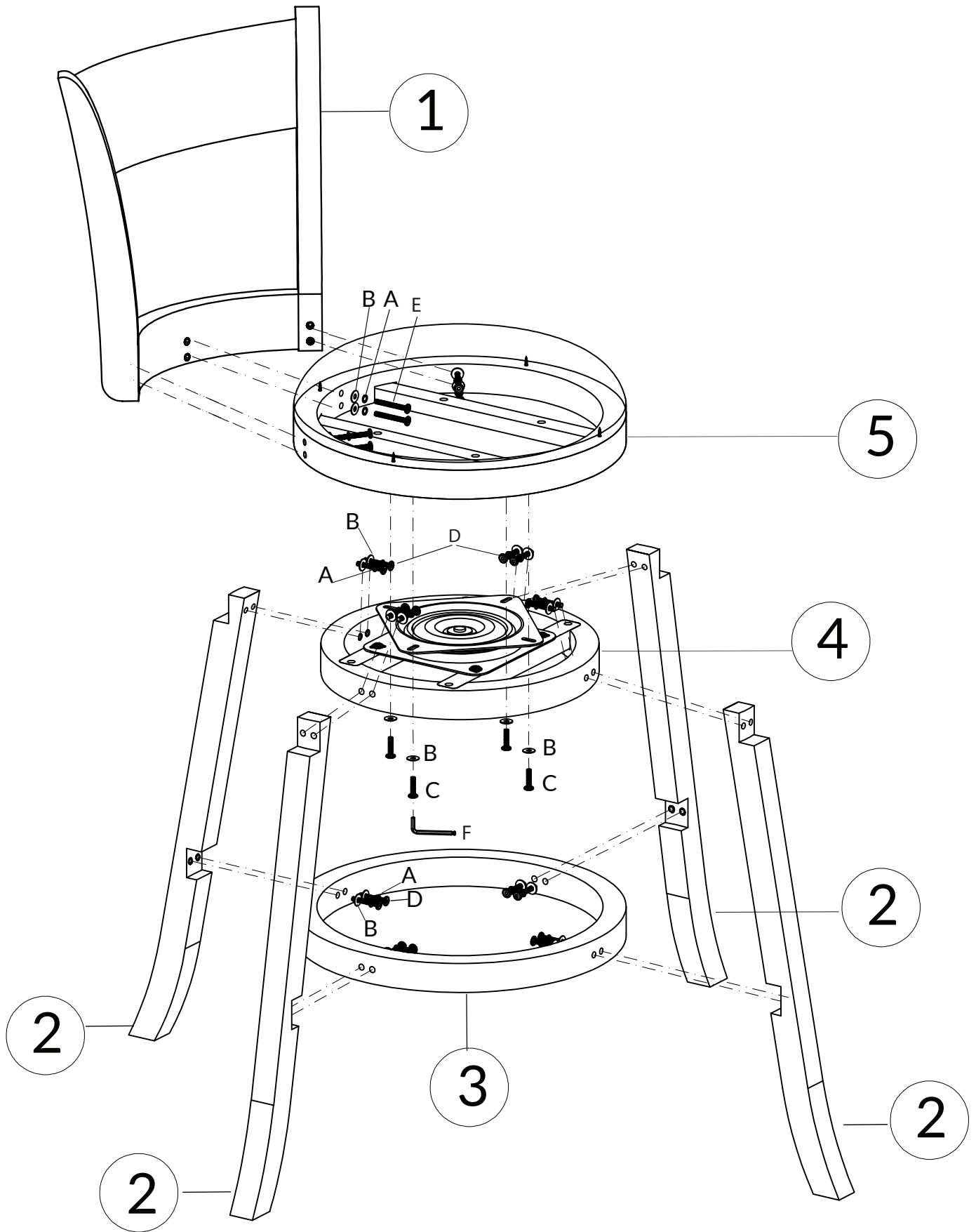

# Assembly Overview

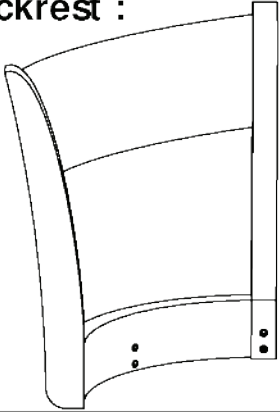

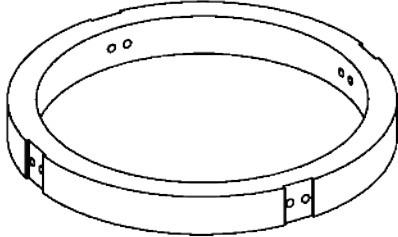
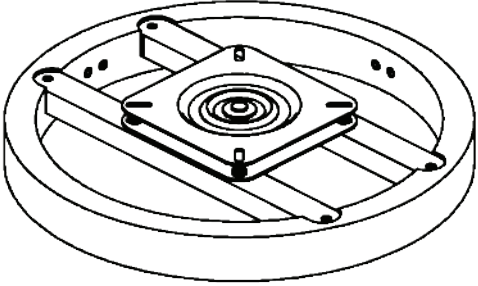
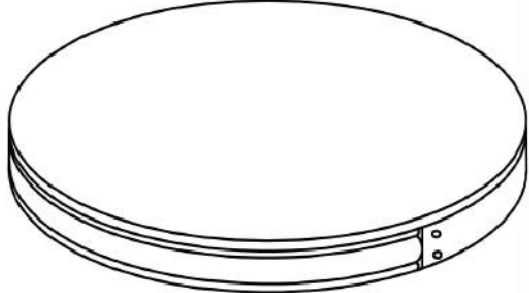
# PARTS

<p>①(x1)</p> <p><b>Backrest :</b></p> 	<p>②(x4)</p> <p><b>Legs :</b></p> 	<p>③(x1)</p> <p><b>Footrest :</b></p> 
<p>④(x1)</p> <p><b>Apron With Swivel Plate :</b></p> 	<p>⑤(x1)</p> <p><b>Seat Cushion :</b></p> 	

# HARDWARE

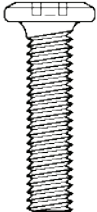
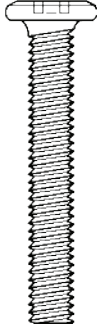
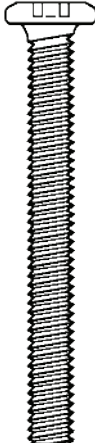
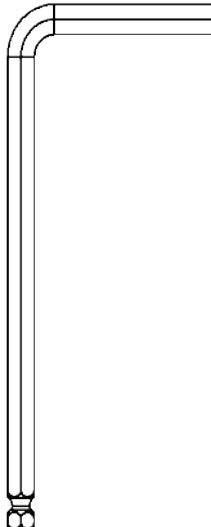
<p>Ⓐ(x22)</p> 	<p>Ⓑ(x26)</p> 	<p>Ⓒ(x4)</p> 	<p>Ⓓ(x16)</p> 	<p>Ⓔ(x6)</p> 	<p>Ⓕ(x1)</p> 
<p>Spring Washer M6*10</p>	<p>Flat Washer M6*16</p>	<p>Bolt M6*25</p>	<p>Bolt M6*40</p>	<p>Bolt M6*50</p>	<p>Allen Wrench M4*110</p>

847-949-6300 | 877-267-2261 | [customerservice@boraamindustries.com](mailto:customerservice@boraamindustries.com)

# 01

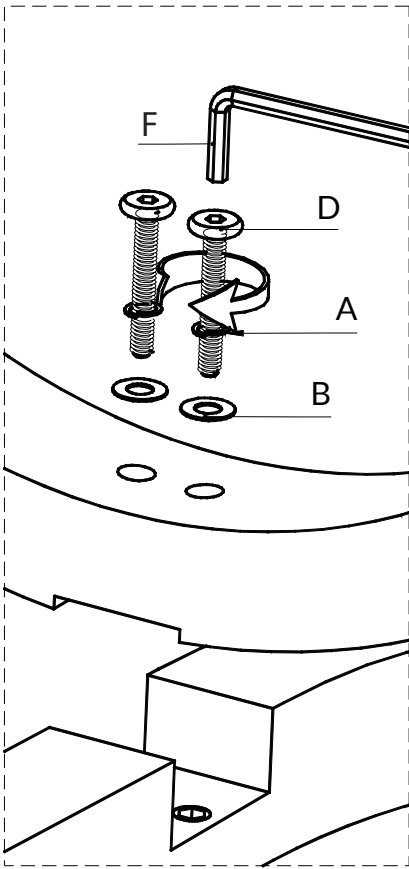

4X

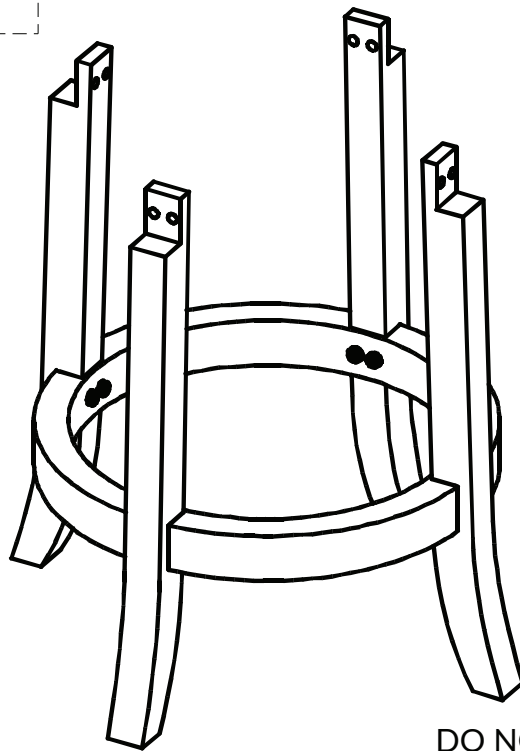
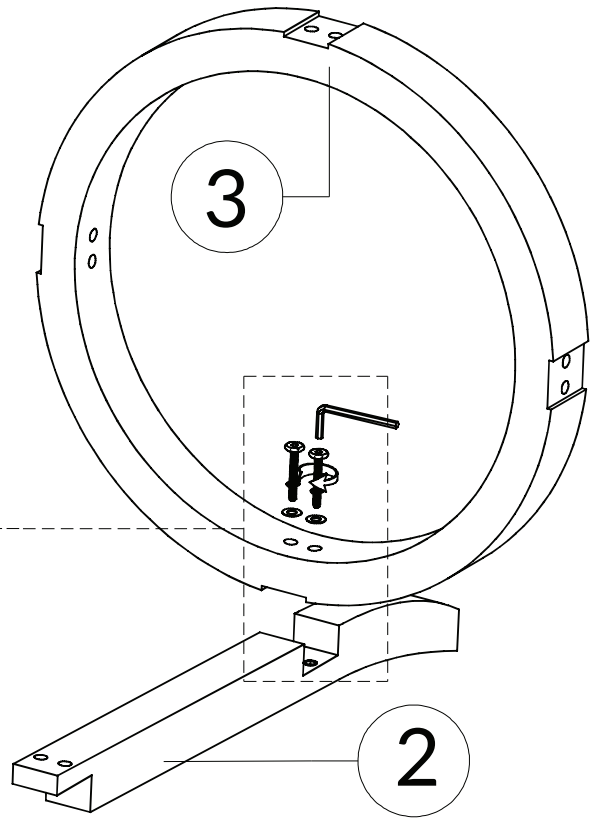

Hardware	Count
A	8
B	8
D	8
F	1

DO NOT TIGHTEN BOLT COMPLETELY.

Please make sure that the protective metal kick plate from Footrest (Part #3) is facing upwards.  
Remove the white Tape from the protective metal kick plate before using.

847-949-6300 | 877-267-2261 | [customerservice@boraamindustries.com](mailto:customerservice@boraamindustries.com)

# 02

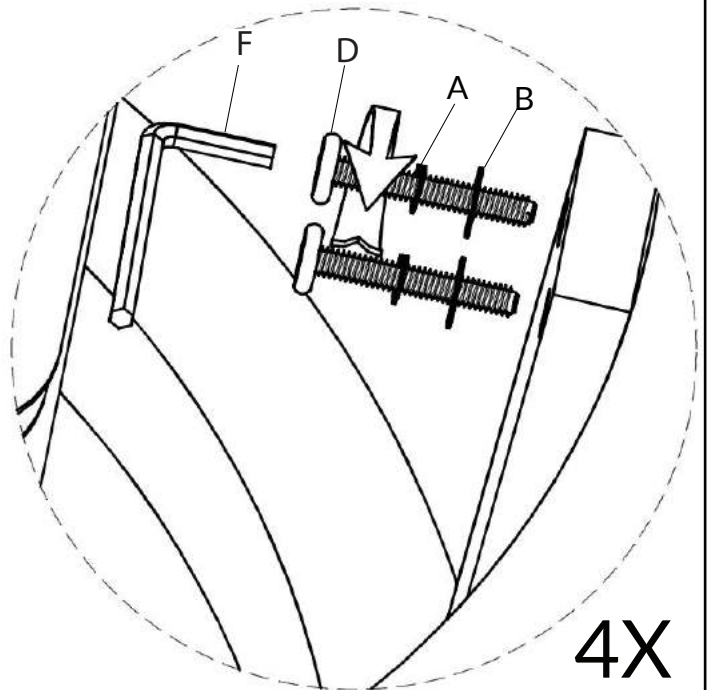
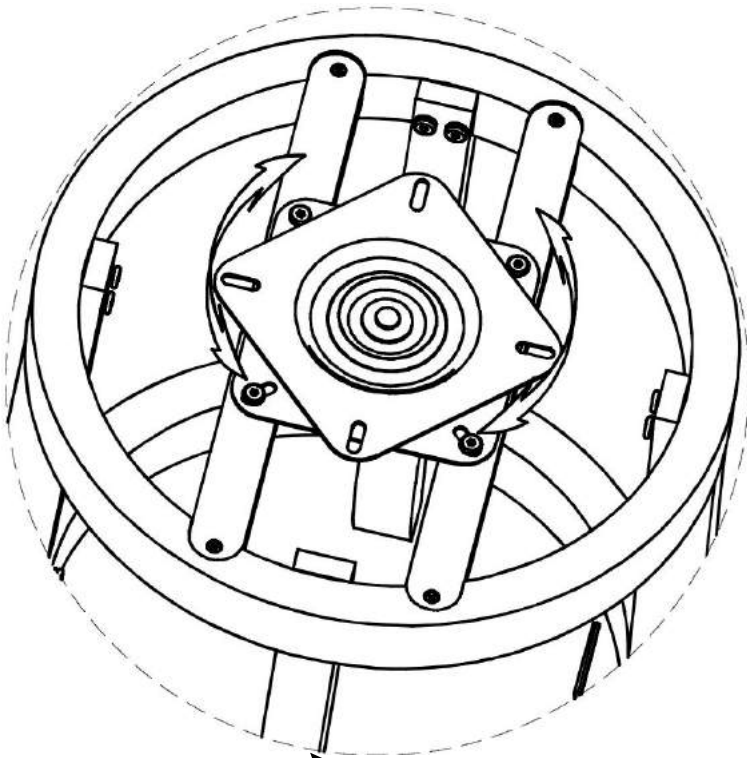

4

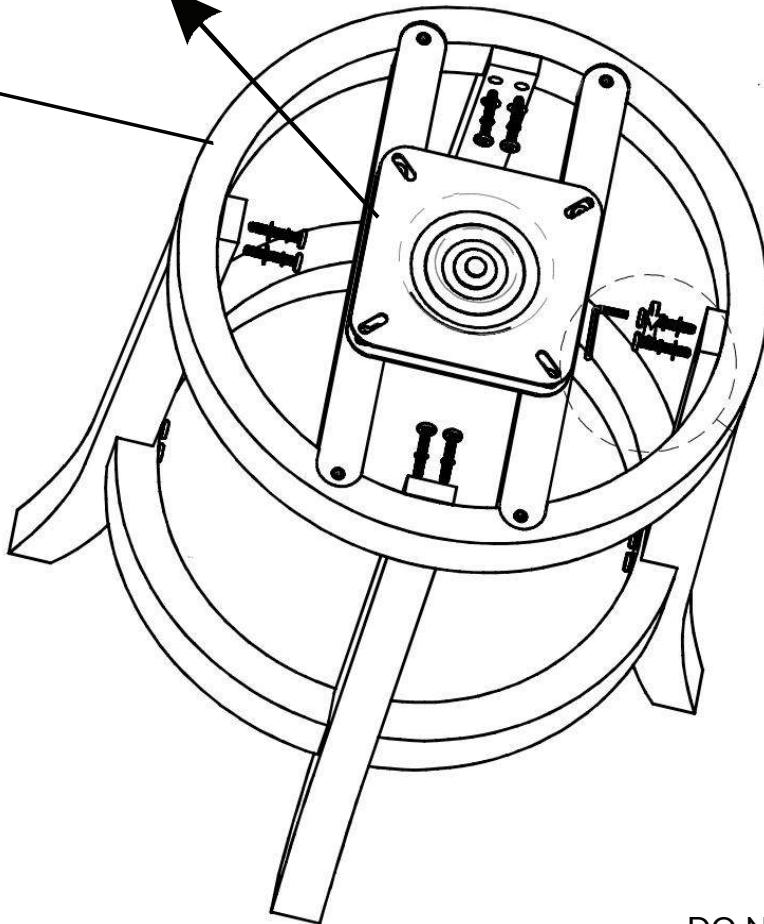

Hardware	Count
A	8
B	8
D	8
F	1

DO NOT TIGHTEN BOLT COMPLETELY.

# 03

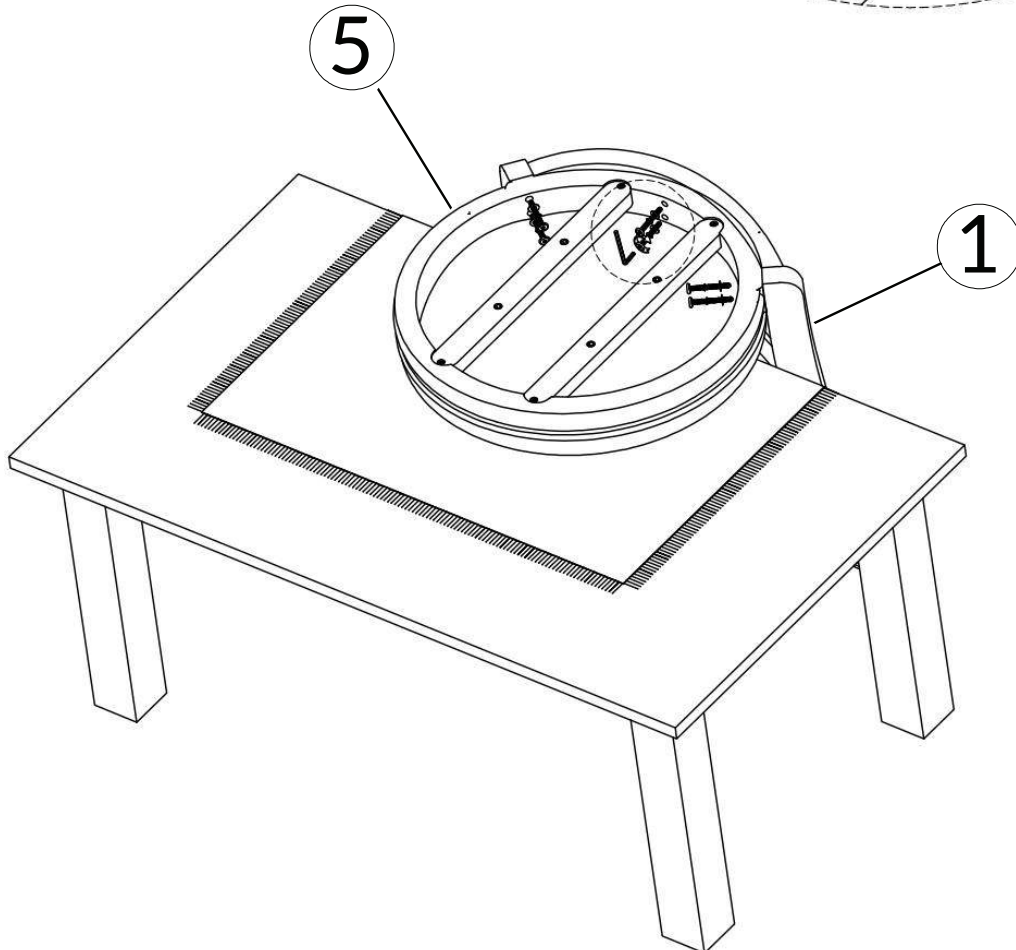
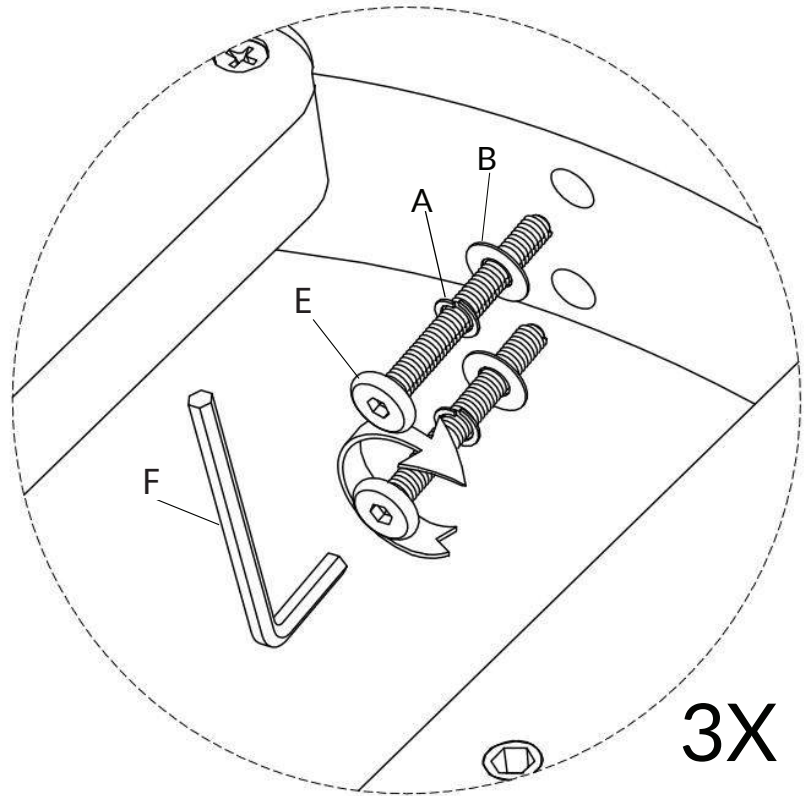

Hardware	Count
A	6
B	6
E	6
F	1

TIGHTEN BOLT COMPLETELY.

# 04

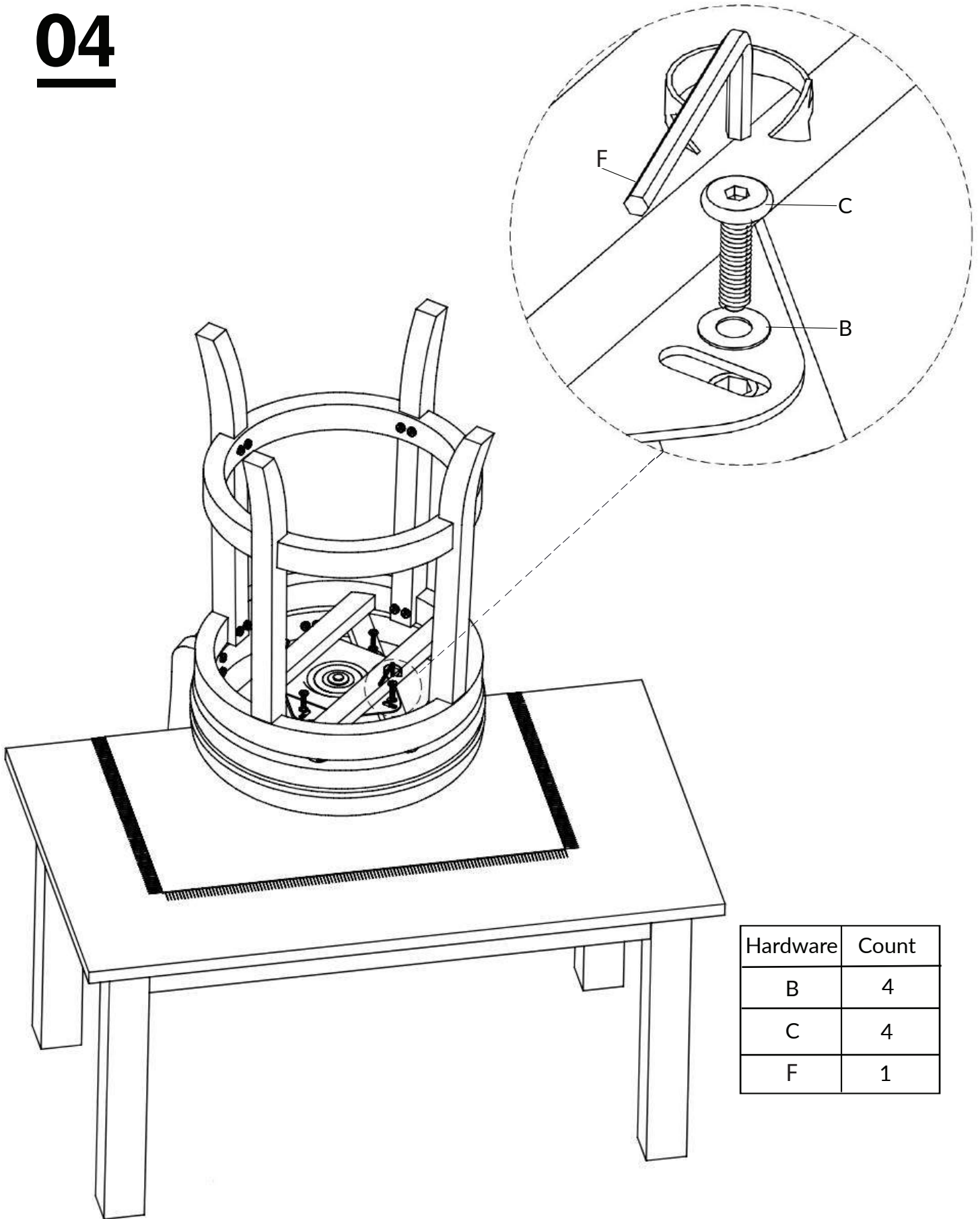

Hardware	Count
B	4
C	4
F	1

TIGHTEN BOLT COMPLETELY.

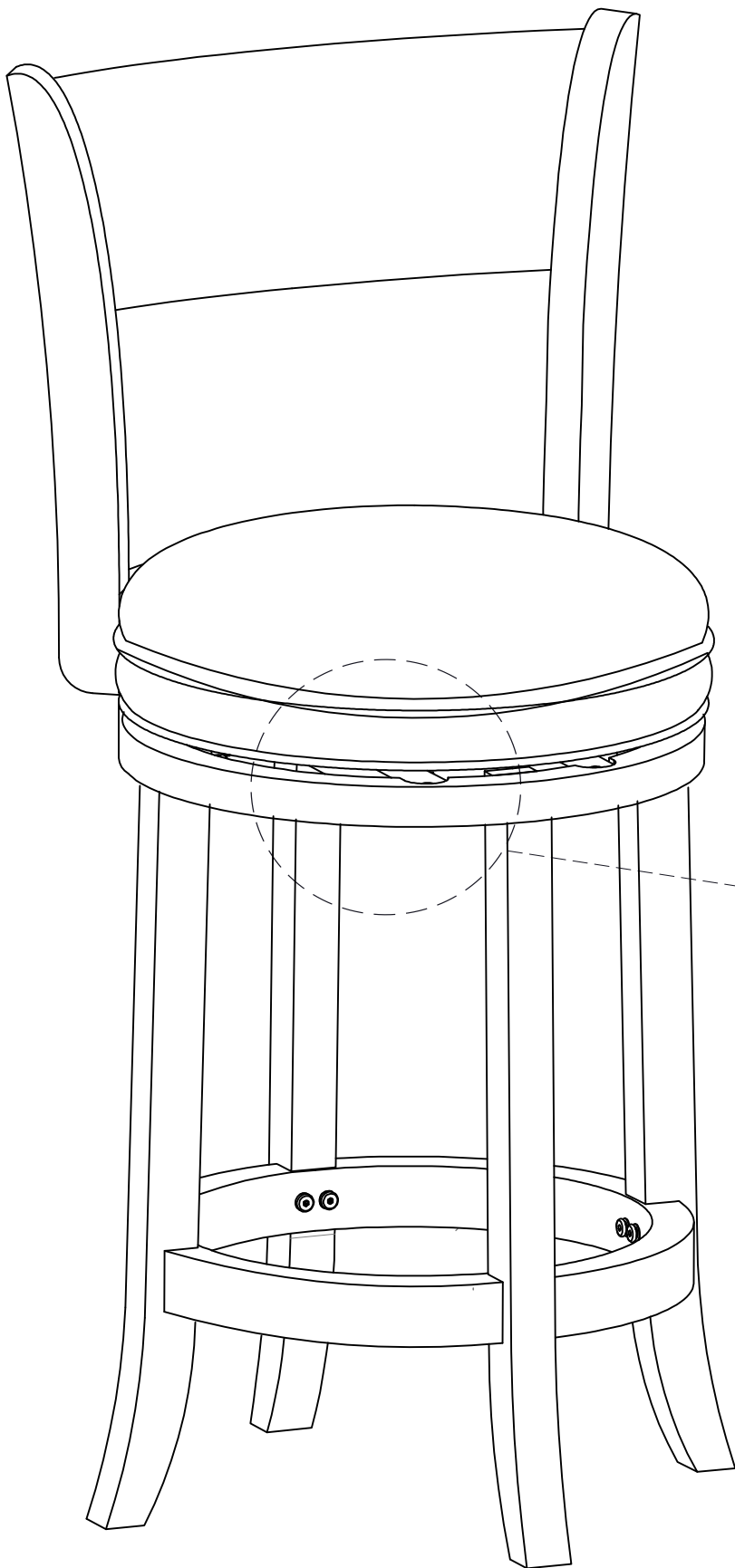

**Weight Capacity**

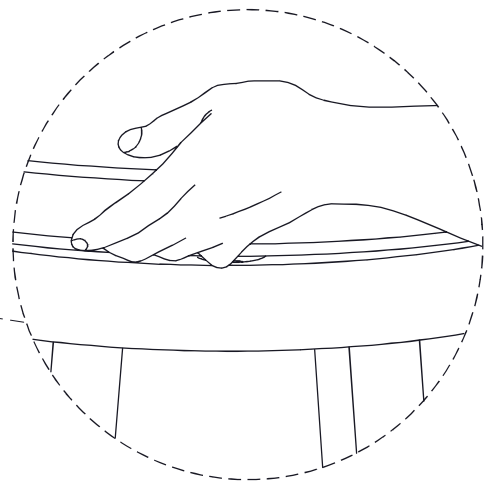

**BE SURE TO CHECK ALL BOLTS ARE SECURELY TIGHTENED PRIOR TO USE.**

847-949-6300 | 877-267-2261 | [customerservice@boraamindustries.com](mailto:customerservice@boraamindustries.com)