



# Boraam Industries

ASSEMBLY INSTRUCTIONS

SKU: 76824,76829,76924,76929

## MYRTLE SWIVEL STOOL

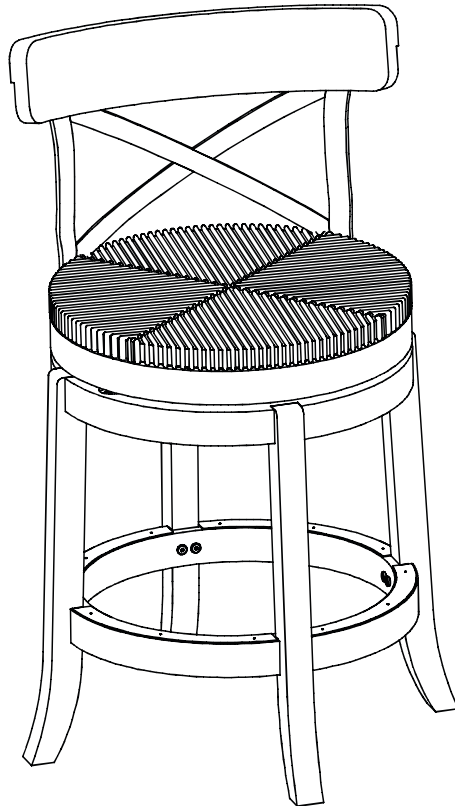

**Weight Capacity**



Locate the **HARDWARE PACK** which is attached to the shipping carton with red tape.

01/2024



Have questions about assembling your item?



Items or parts damaged?



Missing a part?

**We're here to help! (Monday-Friday from 9am-5pm CST)**



847-949-6300  
877-267-2261



customerservice@  
boraamindustries.com



www.boraamindustries.com

# Assembly And Care

- All tools required for assembly are included unless noted.
- Prior to assembly, check for missing or damaged parts.
- Do not dispose of packing materials until assembly is completed.
- Assemble item on a soft, clean surface to prevent damage to the item.



Locate the **HARDWARE PACK** which is attached to the shipping carton with red tape.

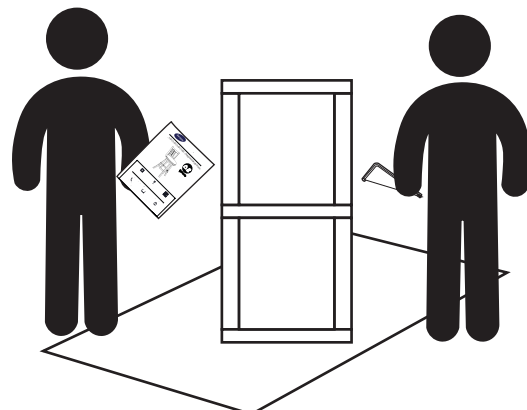
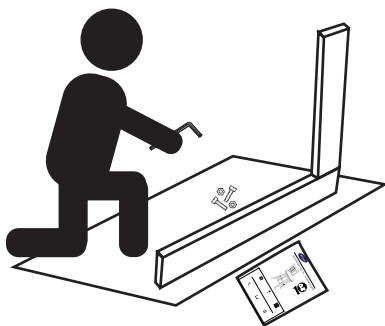
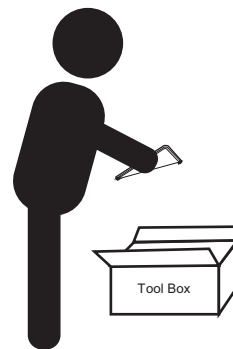
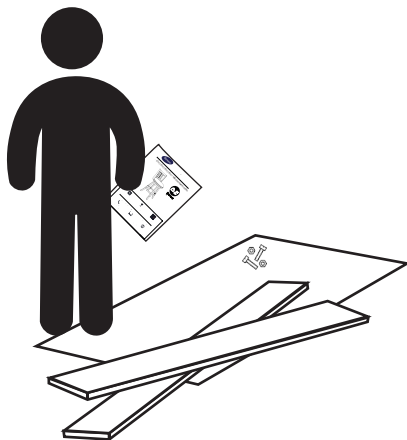

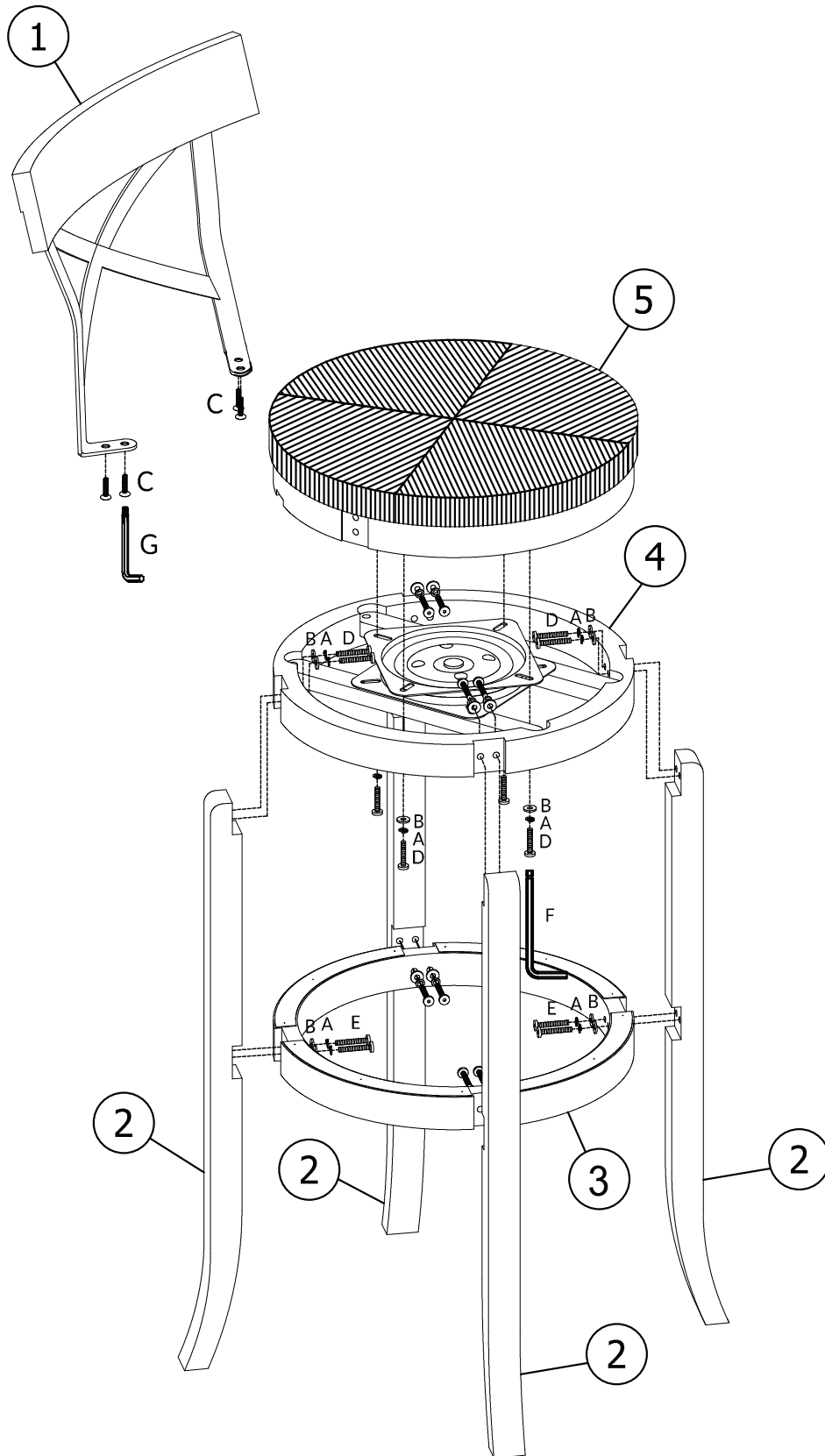

# Assembly Overview

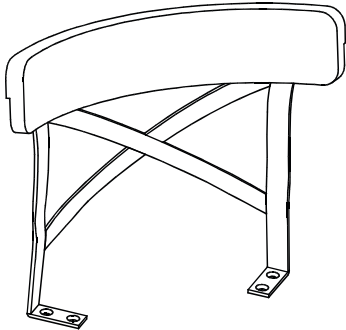
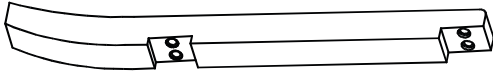
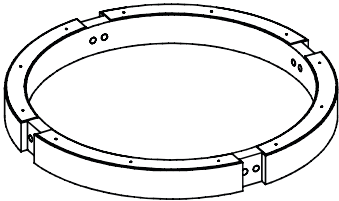
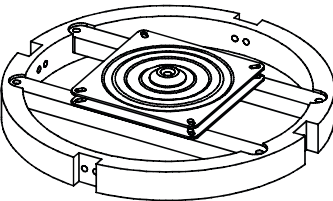
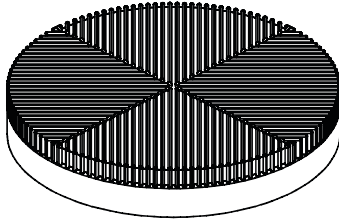

# PARTS

① (x1)		② (x4)	
<b>Backrest:</b> 		<b>Leg:</b> 	
③ (x1)	④ (x1)		⑤ (x1)
<b>Footrest:</b> 	<b>Apron With Swivel Plate:</b> 		<b>Seat Cushion:</b> 

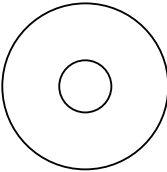
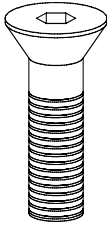
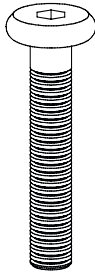
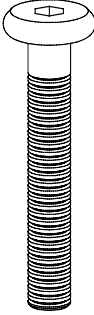
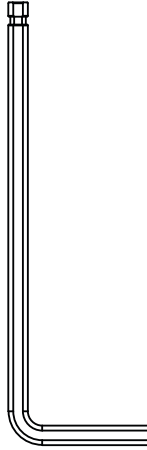
# HARDWARE

Ⓐ (x20)	Ⓑ (x20)	Ⓒ (x4)	Ⓓ (x12)	Ⓔ (x8)	Ⓕ (x1)	Ⓖ (x1)
						
SpringWasher M6x10	Flat Washer M6x16	Bolt M8x25	Bolt M6x30	Bolt M6x35	Allen Wrench M4x110	Allen Wrench M5x80

# 01

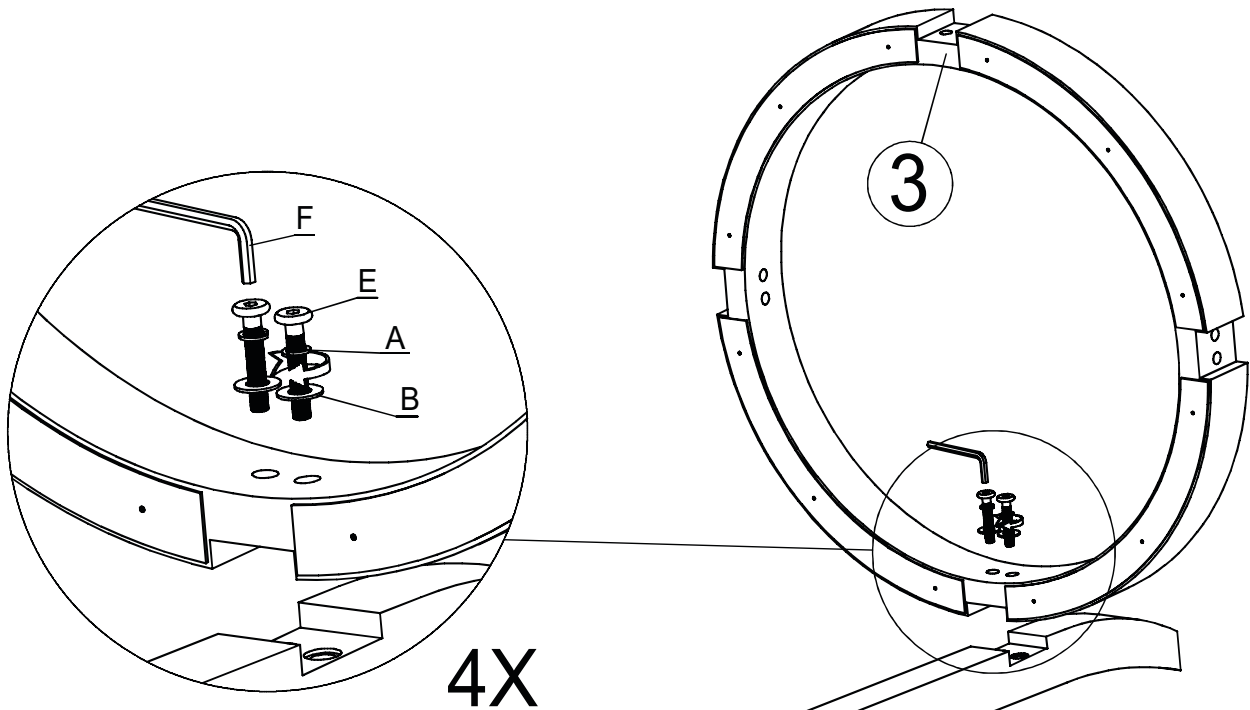

4X

2

3

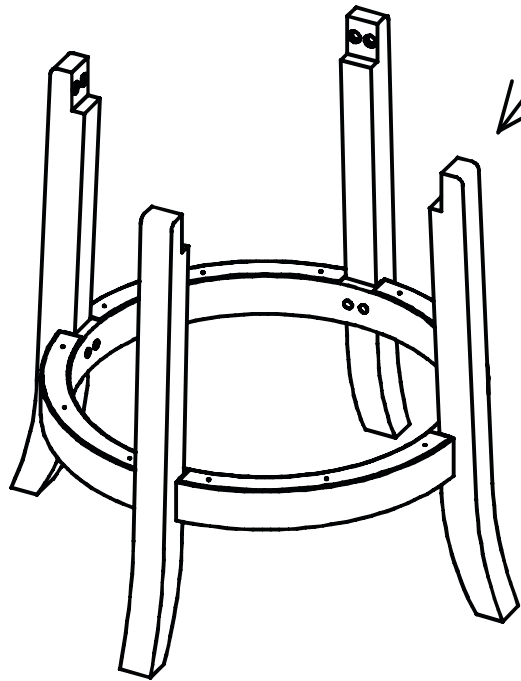

Please make sure that the protective metal kick plate from Footrest (Part #3) is facing upwards. Remove the white Tape from the protective metal kick plate before using.

Hardware	Count
A	8
B	8
E	8
F	1

DO NOT TIGHTEN BOLT COMPLETELY.

# 02

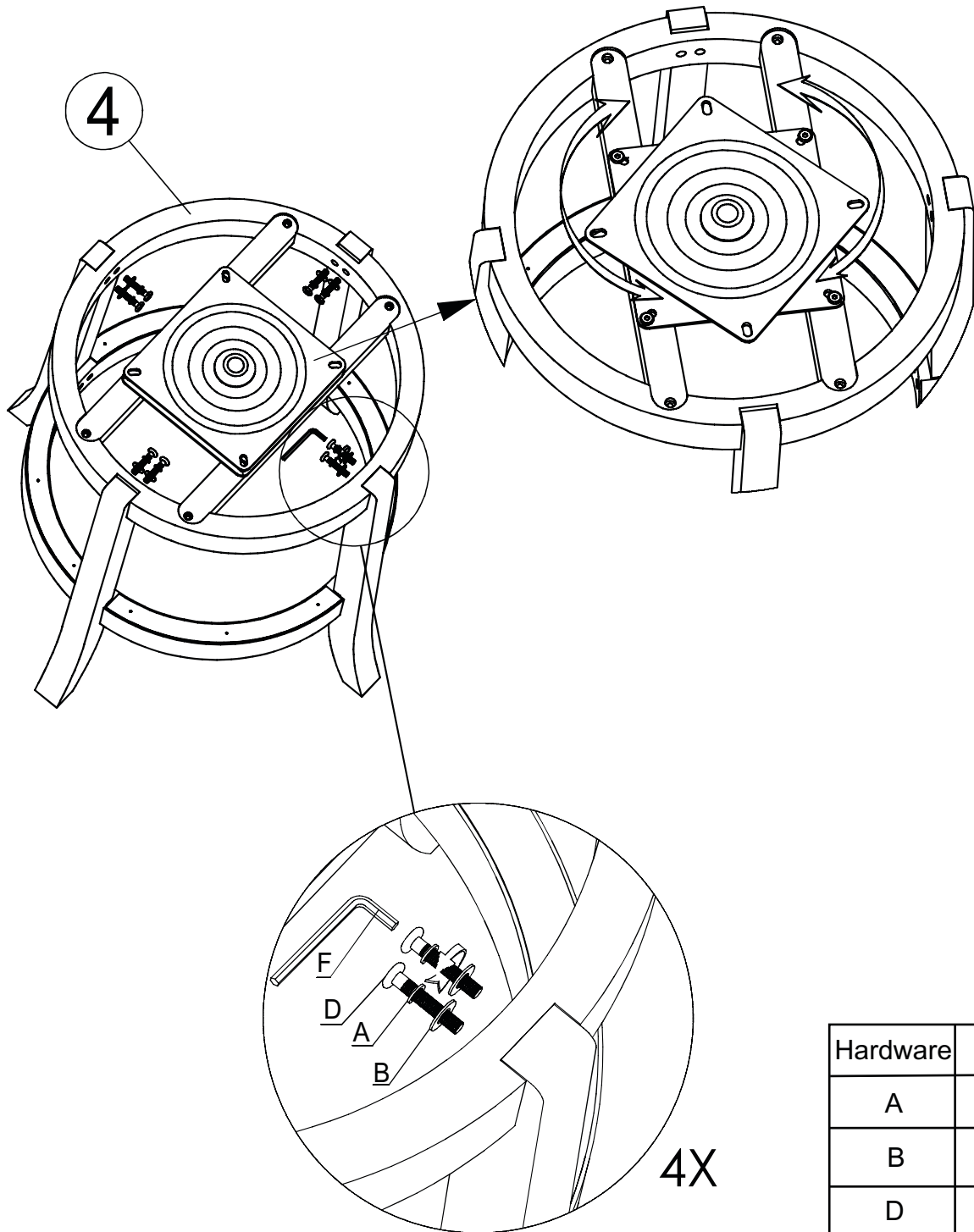

Hardware	Count
A	8
B	8
D	8
F	1

TIGHTEN BOLT COMPLETELY.

# 03

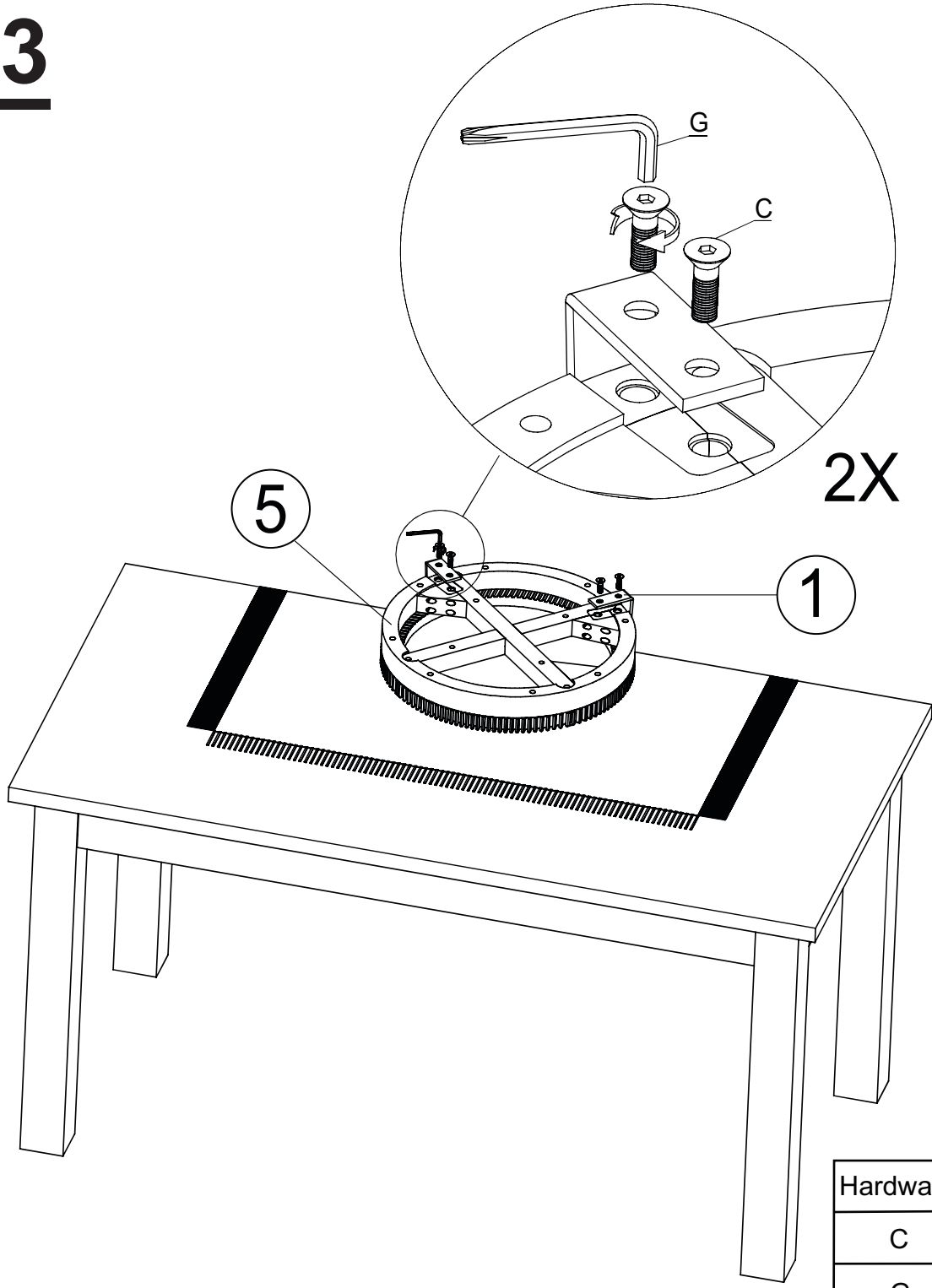

Hardware	Count
C	4
G	1

TIGHTEN BOLT COMPLETELY.

# 04

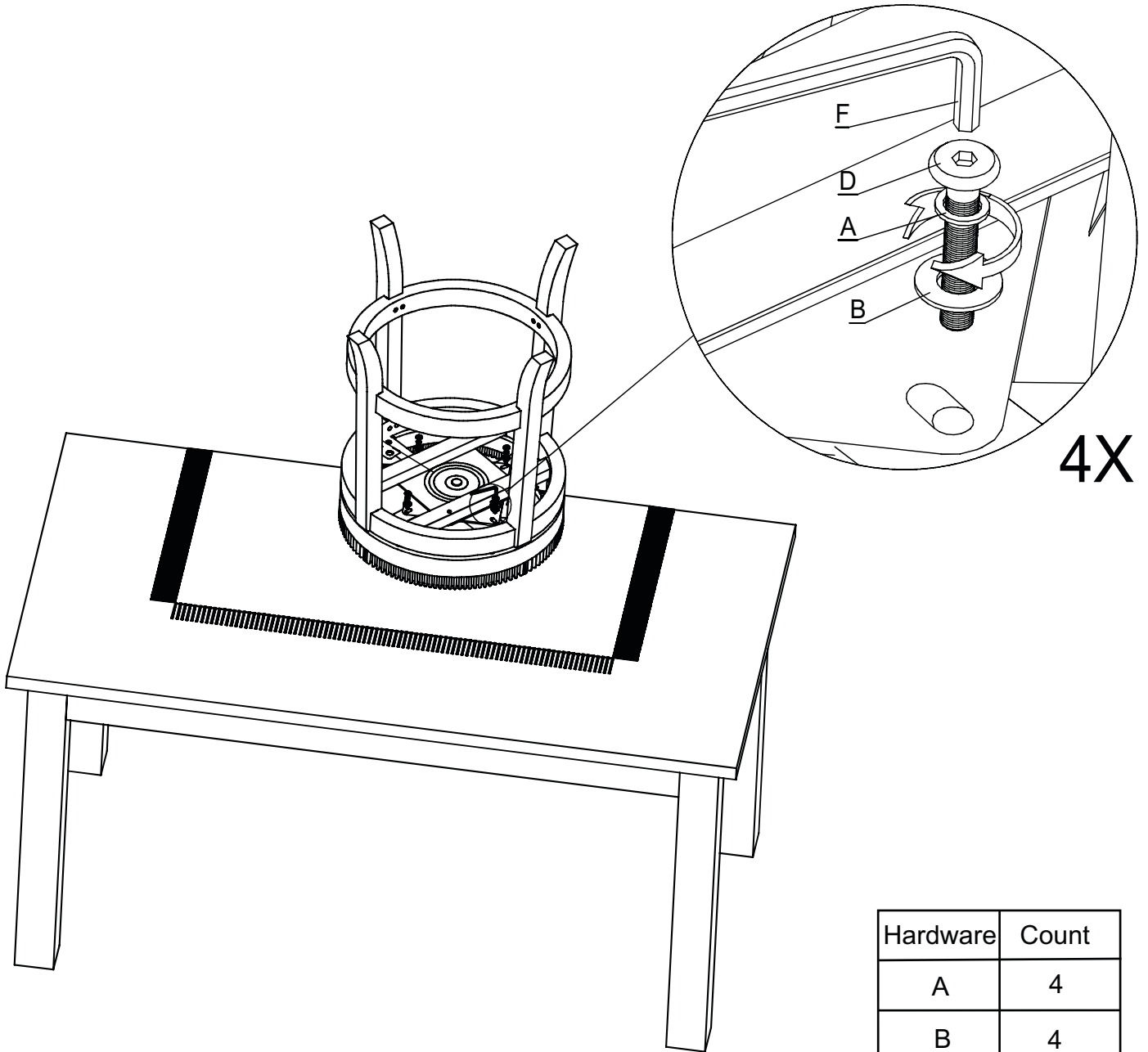

Hardware	Count
A	4
B	4
D	4
F	1

TIGHTEN BOLT COMPLETELY.





**Weight Capacity**

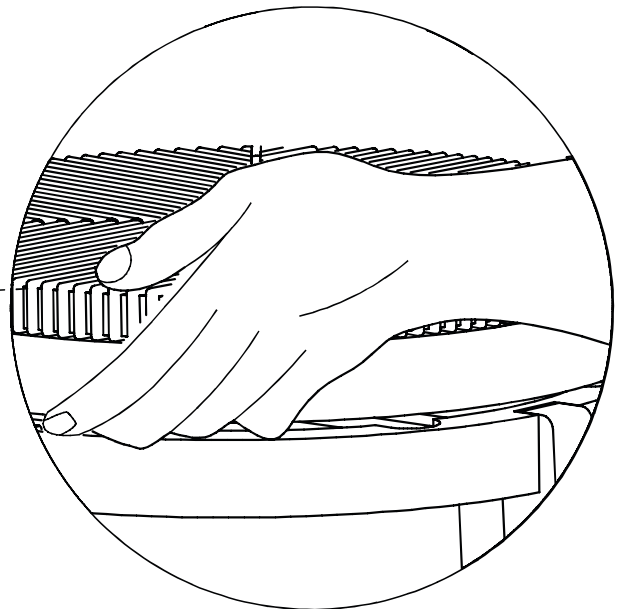
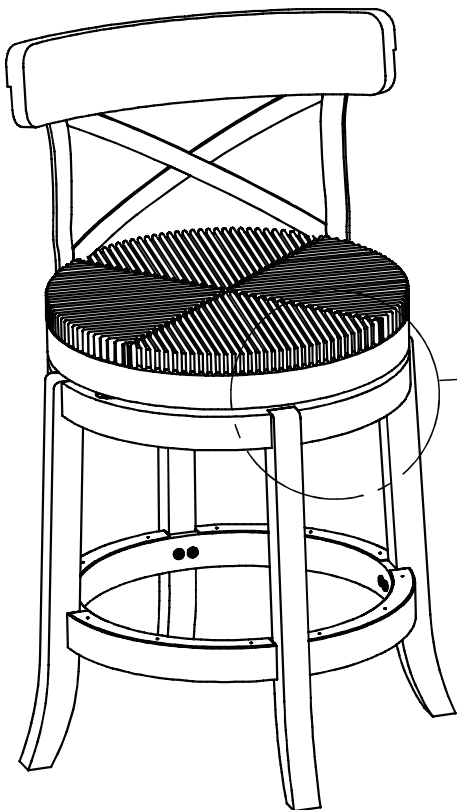

**BE SURE TO CHECK ALL BOLTS ARE SECURELY TIGHTENED PRIOR TO USE.**