

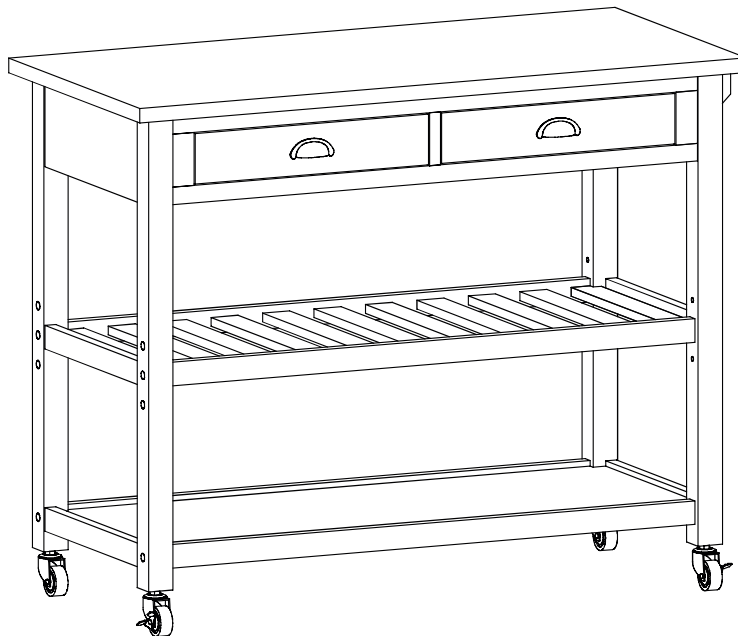

Boraam Industries

ASSEMBLY INSTRUCTIONS

SKU: 98520,98523
SONOMA KITCHEN CART



Weight Capacity



Locate the **HARDWARE PACK** which is attached to the shipping carton with red tape.

01/2024



Have questions about assembling your item?



Items or parts damaged?



Missing a part?

We're here to help! (Monday-Friday from 9am-5pm CST)



847-949-6300
877-267-2261



customerservice@
boraamindustries.com



www.boraamindustries.com

Assembly And Care

- All tools required for assembly are included unless noted.
- Prior to assembly, check for missing or damaged parts.
- Do not dispose of packing materials until assembly is completed.
- Assemble item on a soft, clean surface to prevent damage to the item.



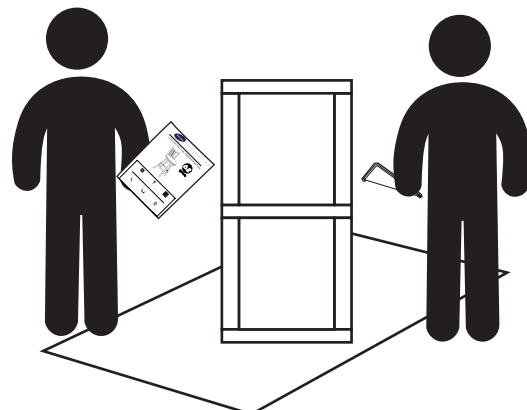
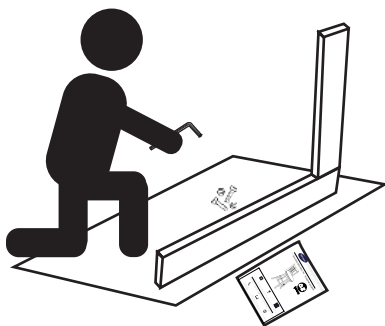
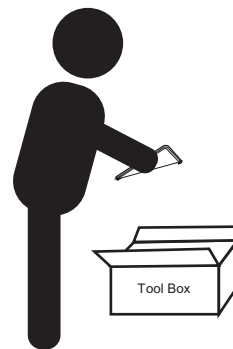
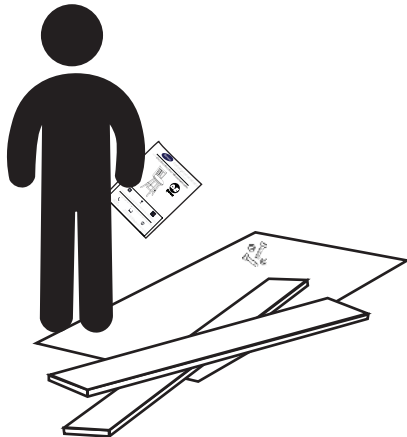

Locate the **HARDWARE PACK** which is attached to the shipping carton with red tape.

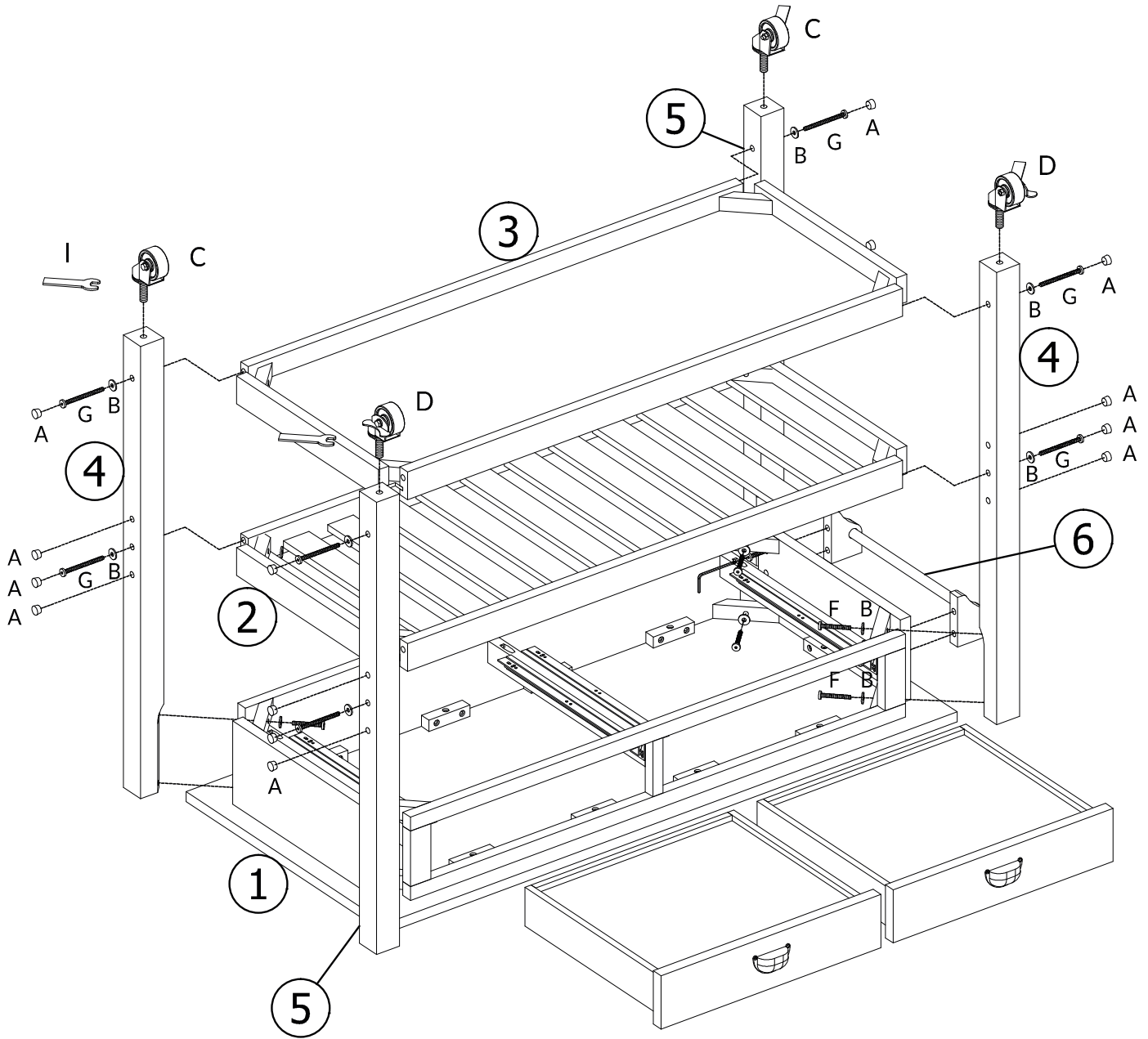

Assembly Overview

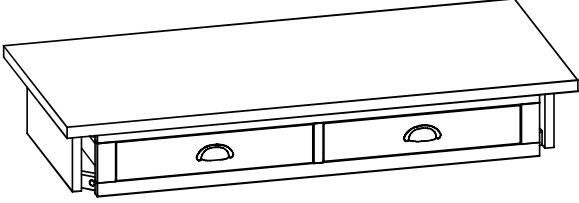
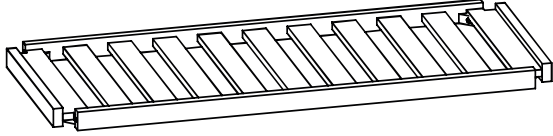
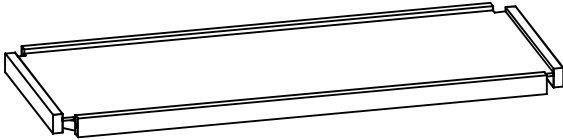

PARTS

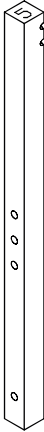
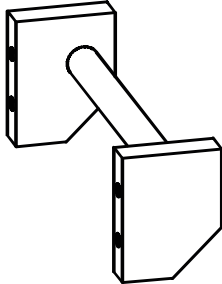
<p>① (x1)</p>	<p>② (x1)</p>
<p>Top with Drawers:</p> 	<p>Middle shelf:</p> 
<p>③ (x1)</p>	<p>④ (x2)</p>
<p>Bottom shelf:</p> 	<p>Left leg:</p> 
<p>⑤ (x2)</p>	<p>⑥ (x1)</p>
<p>Right leg:</p> 	<p>Rack:</p> 

HARDWARE

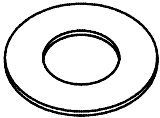
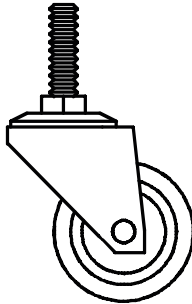
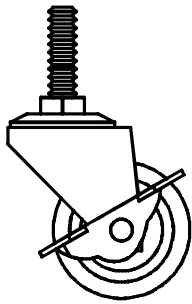
Ⓐ (x16)	Ⓑ (x8)	Ⓒ (x2)	Ⓓ (x2)
			
Wood Nut	Flat Washer	Caster	Caster With Lock

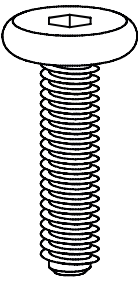
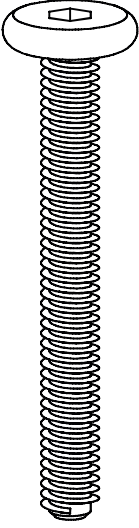
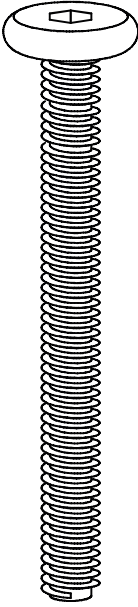
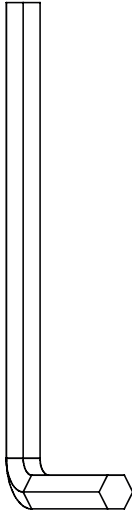
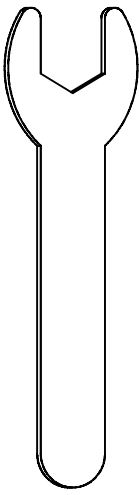
Ⓔ (x4)	Ⓕ (x8)	Ⓖ (x8)	Ⓗ (x1)	Ⓘ (x1)
				
Bolt M6x35	Bolt M6x50	Bolt M6x60	Allen Wrench	Wrench

01

2X

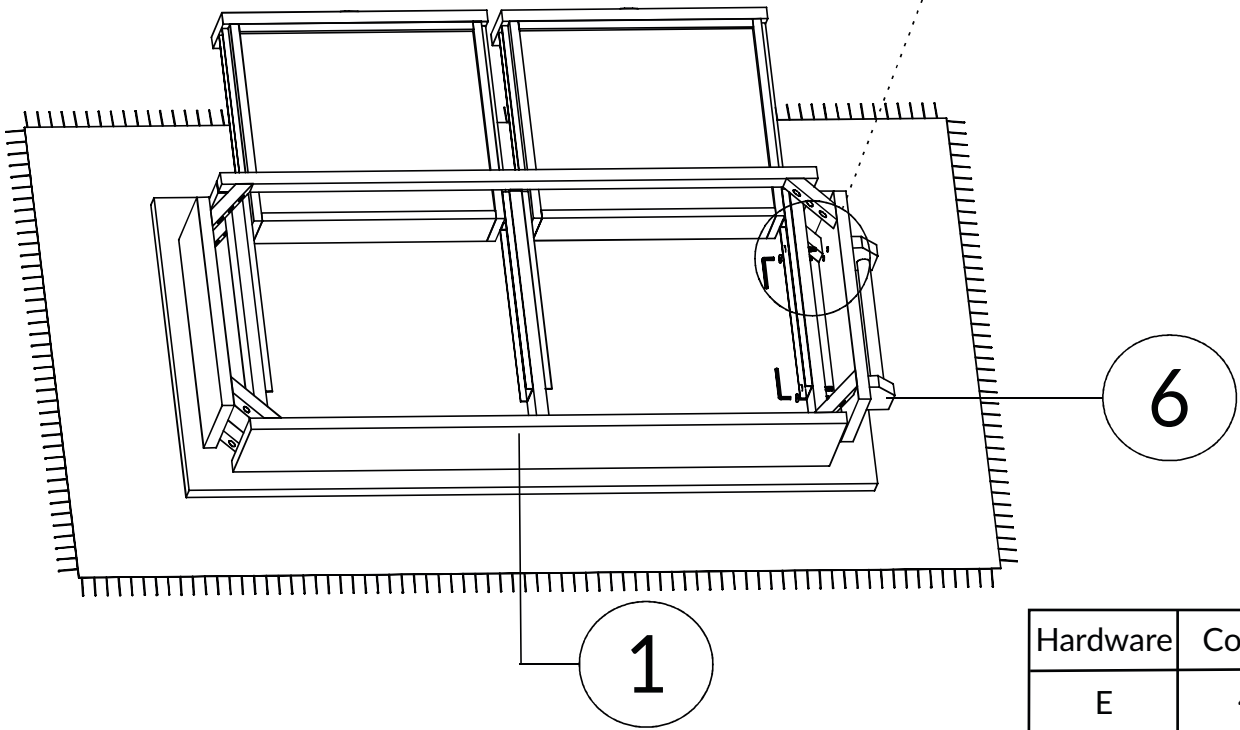
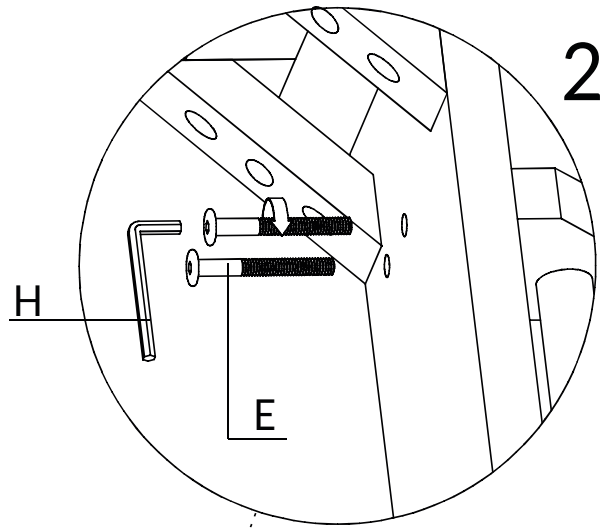

Hardware	Count
E	4
H	1

TIGHTEN BOLT COMPLETELY.

02

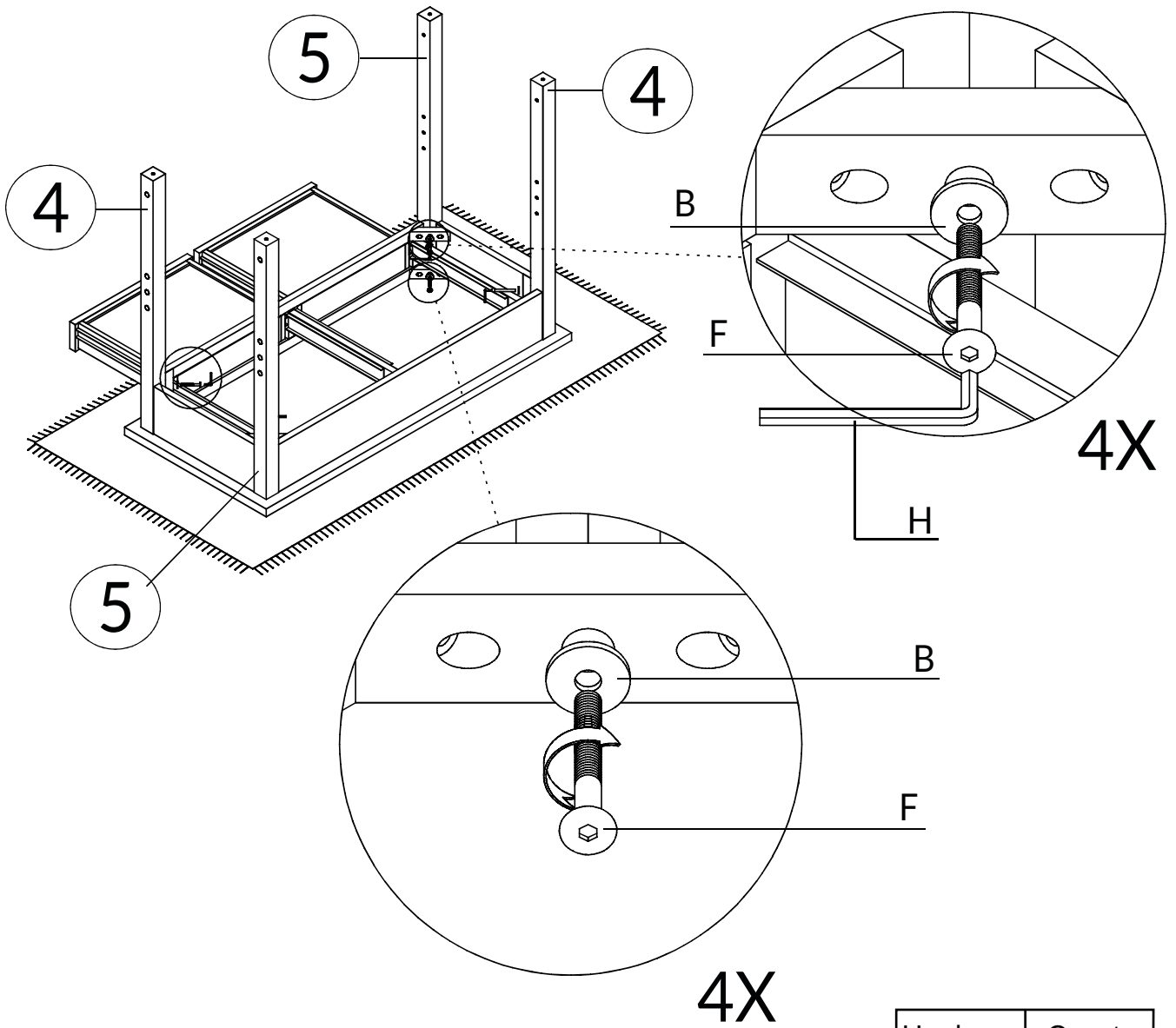

Hardware	Count
B	8
F	8
H	1

DO NOT TIGHTEN BOLT COMPLETELY.

03

1. Make sure the insert nuts are in the correct position before assembling.
2. You will need a screwdriver to turn the nuts into the correct position as shown below.

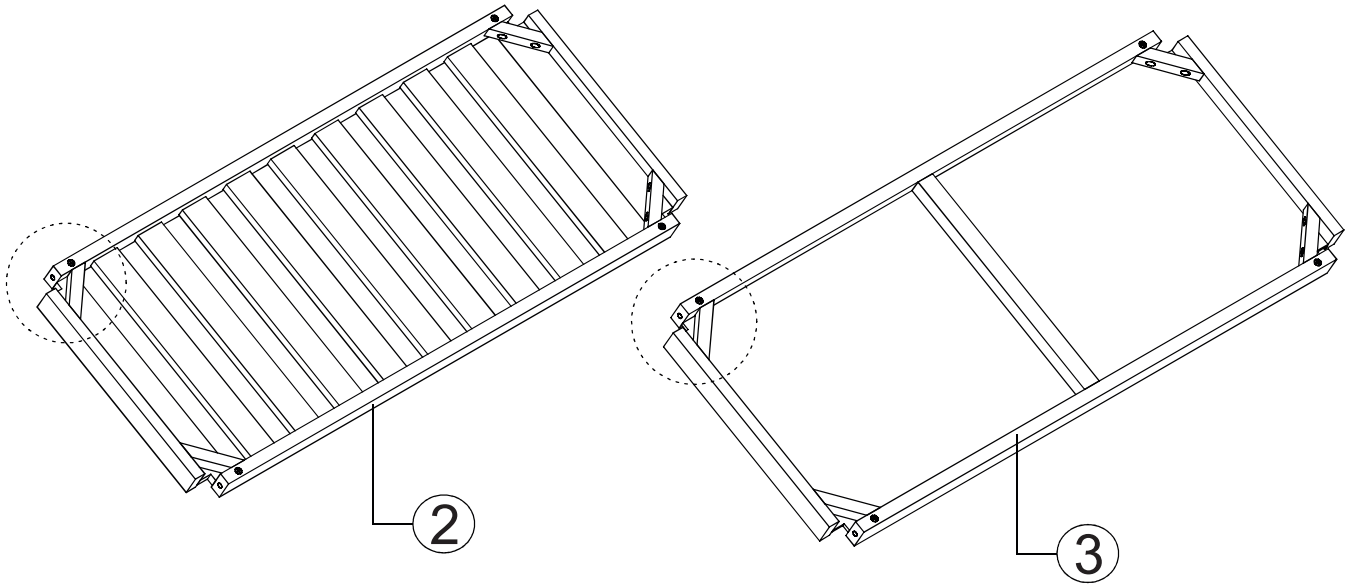

X

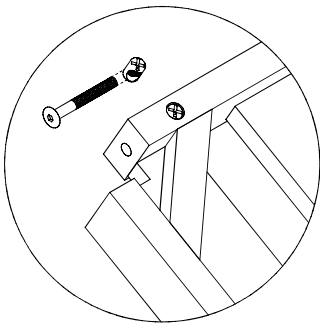

Incorrect

This is to prepare for step 04

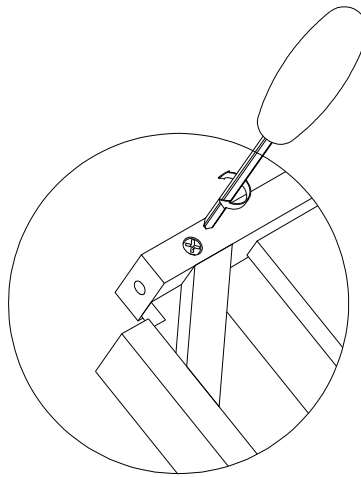

ok

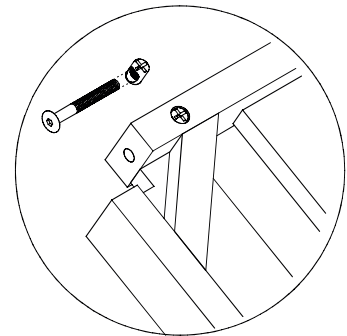

Correct

04

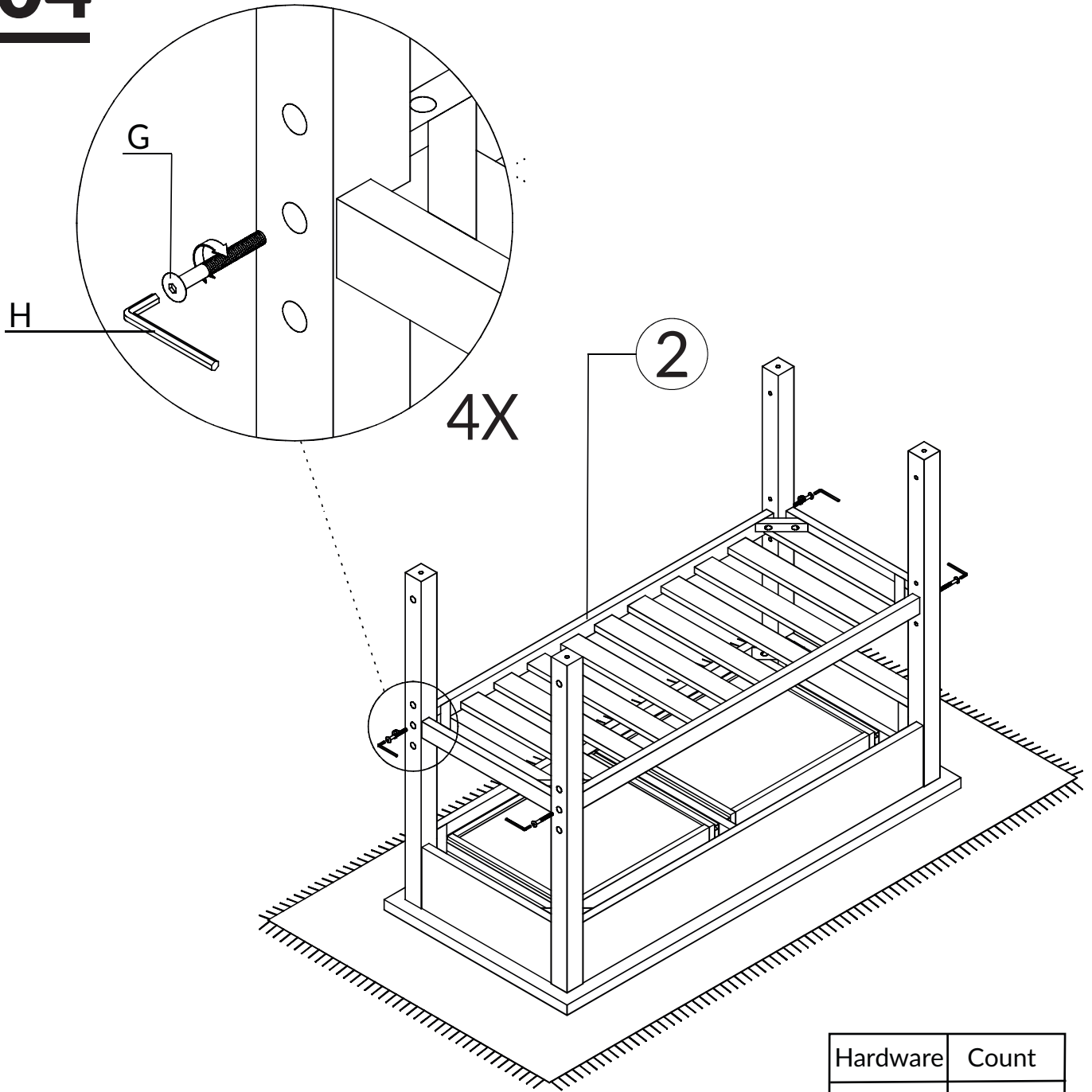

Hardware	Count
G	4
H	1

TIGHTEN BOLT COMPLETELY.

05

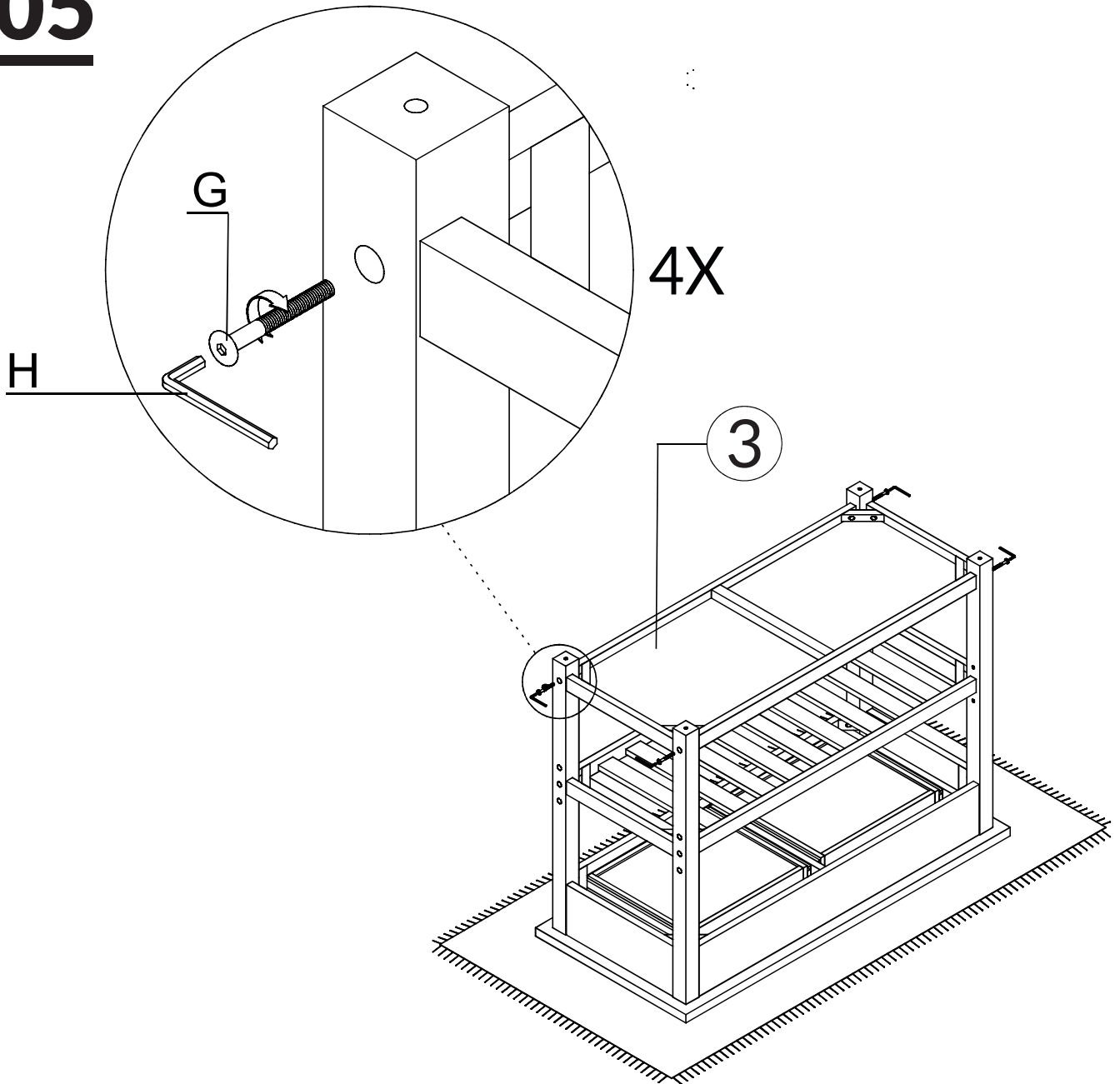

Hardware	Count
G	4
H	1

TIGHTEN BOLT COMPLETELY.

06

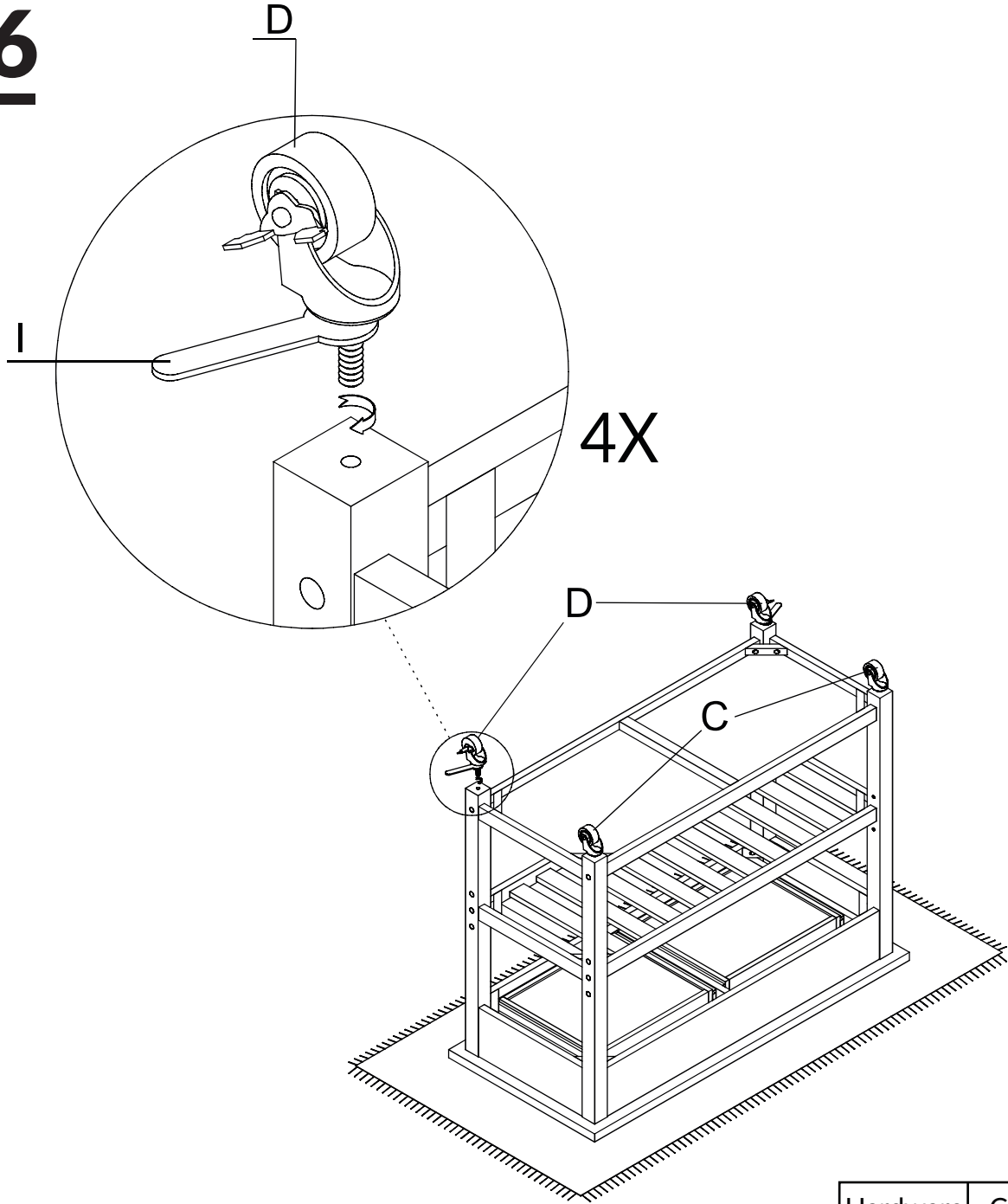

4X

Hardware	Count
C	2
D	2
I	1

TIGHTEN BOLT COMPLETELY.

07

Remove the White Tape from the Tabletop before using.

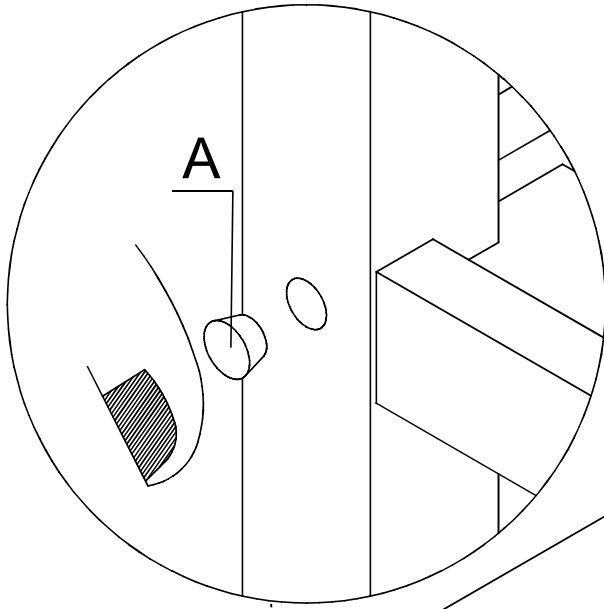

16X

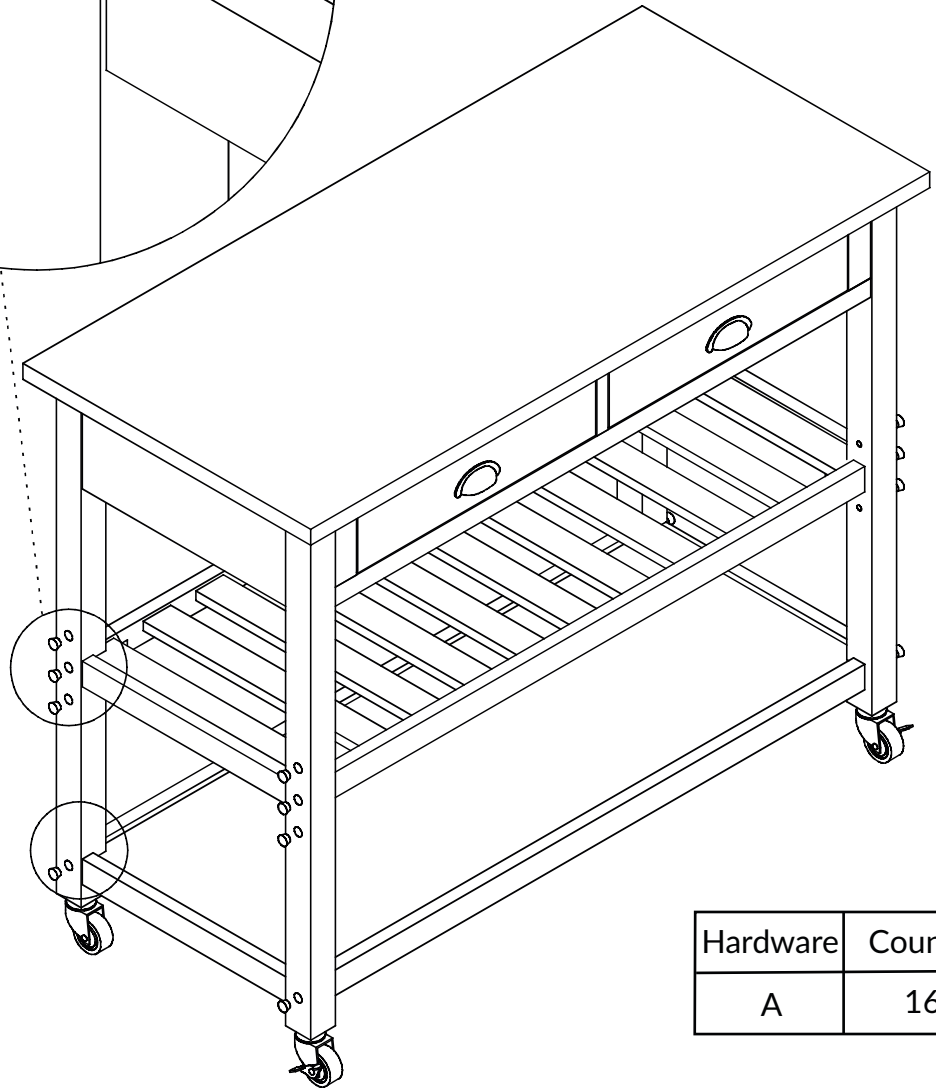

Hardware	Count
A	16



Weight Capacity

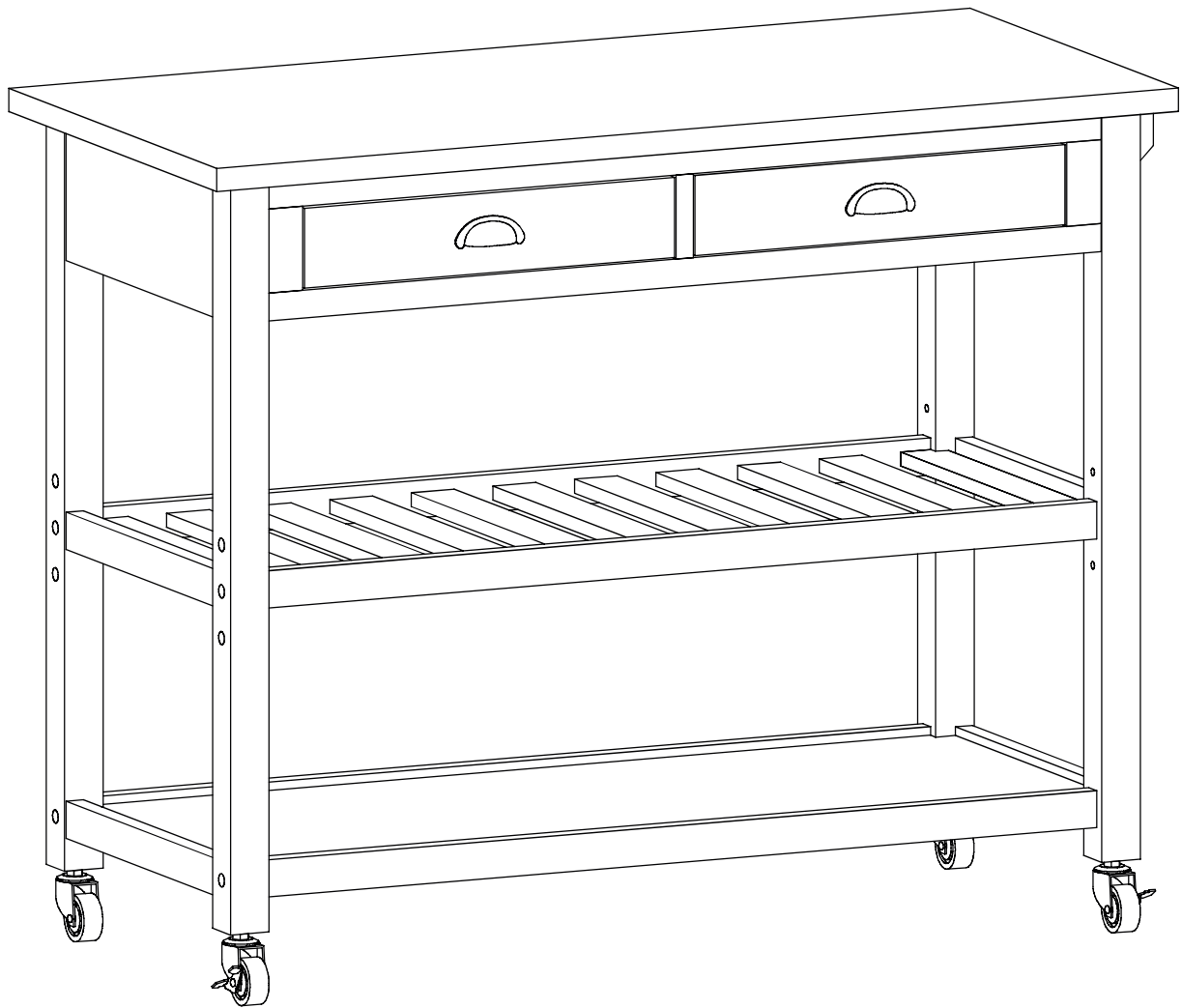

BE SURE TO CHECK ALL BOLTS ARE SECURELY TIGHTENED PRIOR TO USE.

847-949-6300 | 877-267-2261 | customerservice@boraamindustries.com