



Boraam Industries

PALMETTO 34IN. SWVL EXTRA TALL BARSTOOL
Assembly Instructions

- **Tools Included**
- **Do not throw away packing materials until assembly is complete**
- **Assemble this item on a soft, clean surface to protect the product**
- **Proper assembly requires 2 People**
- **Make sure all parts are included prior to assembly**

PART LIST		
NO.	DESCRIPTION	QTY
A	Backrest	1
B	Chair Leg	4
C	Footrest	1
D	Apron with Swivel plate	1
E	Cushion Seat	1

HARDWARE LIST			
NO.	DESCRIPTION	SKETCH	QTY
1	JCBC Bolt M6x25mm		4
2	JCBC Bolt M6x40mm		12
3	JCBC Bolt M6x50mm		6
4	Spring Washer M6x10mm		18
5	Flat Washer 1/4" x 16mm		22
6	Allen Wrench M4		1

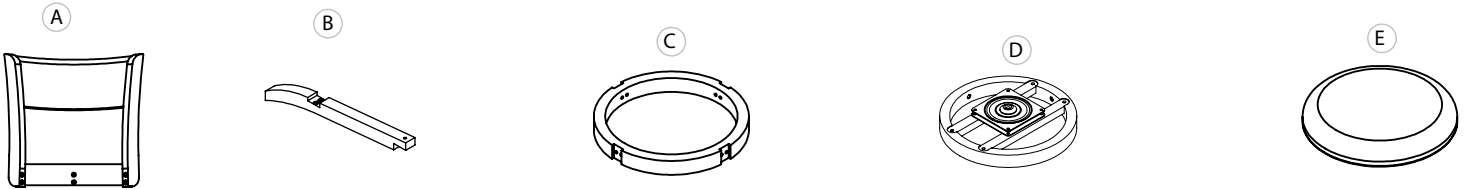

STEP 1

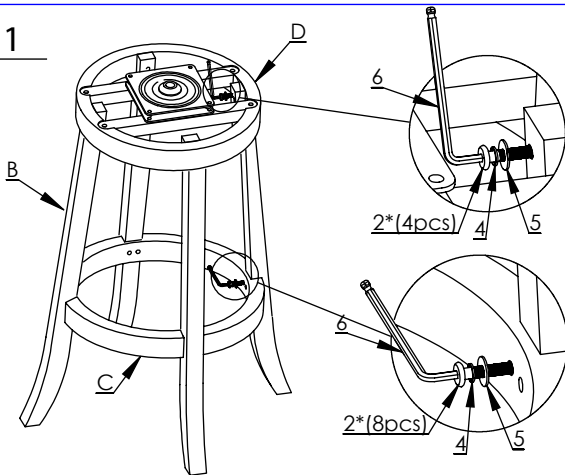

Prepare 16 sets of hardware assemble as shown above :JCBC Bolt(2),spring washer(4) and flat washer(5) in onder.Attach each leg(b) to footrest(c)and apron with swivel plate(D).insert and tighten 1 set of hardware assemble per each hole.
Do NOT TIGHTEN JCBC Bolt completely

STEP 2

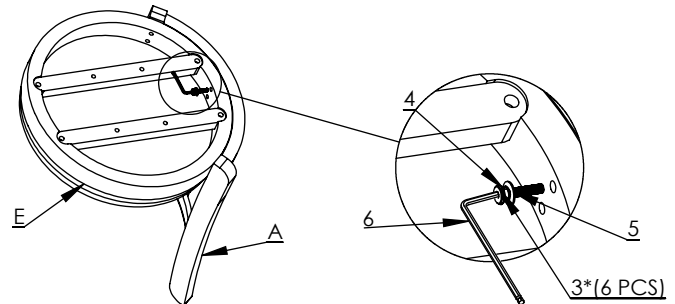

Prepare 6 sets of hardware assemble as shown above: JCBC Bolt (3),spring washer (4) and flat washer (5) in onder.Attach each leg (A) to the seat (E) by inserting and tightening 1 set of hardware assembly per each hole
Tightening 1 set of JCBC Bolt completely with allen key provided once all holes are aligned.

STEP 3

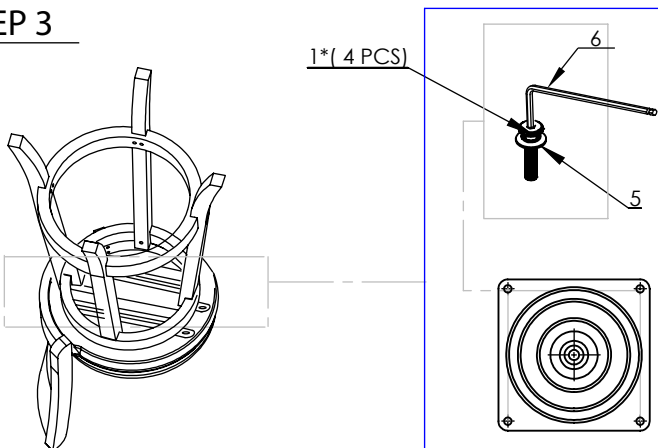

Prepare 4 sets of hardware assemble as shown above: JCBC Bolt (1) and flat washer (5) in onder. Attach stool apron (from step 1), by tuning swivel plate to align each hole. Then insert 1 set of JCBC Bolt assembly per each hole and tighten JCBC Bolt completely.

ASSEMBLY COMPLETE

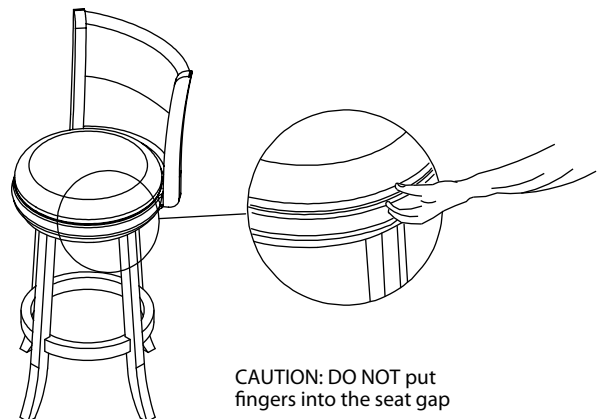

CAUTION: DO NOT put fingers into the seat gap

Be sure to check all JCBC Bolt are securely tightened prior using this stool

COMPLETED ASSEMBLY